



EUROPEAN UNION



fowind
FACILITATING OFFSHORE
WIND IN INDIA



GRID INTEGRATION REPORT

GRID INTEGRATION STUDY FOR OFFSHORE WIND FARM DEVELOPMENT IN GUJARAT AND TAMIL NADU

FOWIND Consortium

April 2017

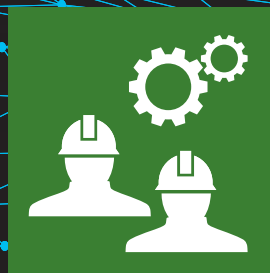
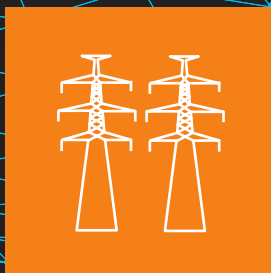





Table of contents

1	EXECUTIVE SUMMARY	5
1.1	Introduction	5
1.2	Background	5
1.3	Onshore Grid Development	5
1.4	Offshore Grid Development	6
1.5	System Operation	8
1.6	Technical and Regulatory Codes	9
1.7	Summary	10
2	INTRODUCTION.....	12
2.1	FOWIND Project Background	12
2.2	Report Purpose	12
2.3	Report Scope	13
3	POWER SECTOR SCENARIO.....	14
3.1	Policy Background	14
3.2	Key Stakeholders of Indian Power Sector	17
3.3	Overview of Gujarat Power Sector	19
3.4	Overview of Tamil Nadu Power Sector	21
4	ONSHORE GRID DEVELOPMENT.....	24
4.1	Overview of Existing Grid Infrastructure in National Level	24
4.2	Overview of Gujarat Power System	31
4.3	Overview of Tamil Nadu Power System	41
4.4	Recommendations	48
5	OFFSHORE GRID DEVELOPMENT.....	49
5.1	Key design Considerations for Offshore Grids	49
5.2	Offshore Grid Technology	50
5.3	Offshore Grid Topologies	61
5.4	500MW Offshore Wind Farm Case Study in India	66
5.5	Offshore Grid Delivery and Ownership Models	70
5.6	Key Challenges for Offshore Wind in India	74
5.7	Recommendations	75
6	SYSTEM OPERATION	76
6.1	Introduction	76
6.2	Power System Operational Issues in National Level	76
6.3	Action Plan at National Level	79
6.4	Power System Operational Issues in Gujarat	80
6.5	Power System Operational Issues in Tamil Nadu	82
6.6	Recommendations	84
7	TECHNICAL AND REGULATORY CODES	85
7.1	Grid Connections	85
7.2	Grid Code	88
7.3	System Planning/Reliability Standards	100
7.4	Key Issues for Offshore Wind in India	102



7.5	Recommendations	103
8	SUMMARY OF RECOMMENDATIONS	105
9	CONCLUSIONS	108
9.1	Delivery of Existing RES Action Plans	108
9.2	Offshore Wind Policy and Code Development	108
9.3	Grid Development Planning	109
9.4	Competence and Capability Development	109
10	REFERENCES.....	110
APPENDIX 1	GETCO REPORT	113
APPENDIX 2	TANGEDCO REPORT	137



List of Acronyms and Abbreviations

ACSR	Aluminium Conductor Steel Reinforced
ALDC	Area Load Dispatch Centre
CAGR	Compound Annual Growth Rate
CAPEX	Capital Expenditure
CEA	Central Electricity Authority
CERC	Central Electricity Regulatory Commission
COP	Conference of Parties
CSA	Cross Sectional Area
CSC	Current Source Converter
CTU	Central Transmission Utility
DISCOM	Electricity Distribution Company
DSM	Deviation Settlement Mechanism
EU	European Union
FY	Financial year (1 April to 31 March in India)
GEC	Green Energy Corridor
GETCO	Gujarat Energy Transmission Corporation Limited
GoI	Government of India
HVAC	High-voltage alternating current
HVDC	High-voltage direct current
IEGC	Indian Electricity Grid Code
INDC	Intended Nationally Determined Contribution
INR	Indian Rupee
Intra-STTS	Intra-State Transmission System
ISTS	Inter-State Transmission System
LTA	Long Term Access
LVRT	Low Voltage Ride Through
MNRE	Ministry of New and Renewable Energy
MoP	Ministry of Power
MVAC	Medium-voltage alternating current



NHPC	National Hydro Power Corporation
NIWE	National Institute of Wind Energy
NLDC	National Load Dispatch Centre
NPCIL	Nuclear Power Corporation of India Limited
NTPC	National Thermal Power Corporation
OWF	Offshore Wind Farm
PCC	Point of Common Coupling
PGCIL	Power Grid Corporation of India Limited
POSOCO	Power System Operation Corporation
PPA	Power Purchase Agreement
PV	Photovoltaic
R&D	Research and Development
REMC	Renewable Energy Management Centre
RES	Renewable Energy Sources
RLDC	Regional Load Dispatch Centre
RPC	Regional Power Committee
RPO	Renewable Purchase Obligation
SEB	State Electricity Board
SERC	State Electricity Regulatory Commission
SLDC	State Load Dispatch Centre
SQSS	Security and Quality of Supply Standards, United Kingdom
STATCOM	Static synchronous compensator
STU	State Transmission Utility
TANGEDCO	Tamil Nadu Generation and Distribution Corporation Limited
TSO	Transmission System Operator
VSC	Voltage Source Converter
XLPE	Cross-linked polyethylene

FOREWORD

On behalf of the FOWIND project consortium, we are pleased to present our latest Grid Integration Study for Offshore Wind in Gujarat and Tamil Nadu an important outcome of the project. The four-year project aims to put together a roadmap for developing a sustainable and commercially viable offshore wind industry in India. This report addresses the following key question on how to prepare the state power systems to connect offshore wind project in Gujarat and Tamil Nadu? The report first provides an overview of relevant policy and wind industry background. It then addresses the steps necessary to prepare the physical onshore grid for integration of offshore wind projects in Gujarat and Tamil Nadu while also considering the requirements to facilitate new offshore grid development. The report also evaluates how the states in question will ensure stable system operation with increasing penetration of offshore wind and other renewable energy generation. It further provides a review of the existing suite of the most relevant grid codes to ensure that they are suitable for development of offshore wind projects in India.

India is growing at a fast pace. Energy is key to achieving India's development goals, to support a rapidly developing economy, to bring electricity to those who remain without it, and to develop the infrastructure to meet the needs of what is soon expected to be the world's most populous country.

India's well-developed wind power industry has the capability and experience to help meet the country's climate and energy security goals. Today India is the 4th largest wind market globally, with total installations having crossed the 31GW mark in March 2017. The industry is firmly on its path to meeting the short-term national target of 60GW by 2022. This will need the local, regional and national TSOs to develop a long-term strategy for higher integration of variable power generation including offshore wind.

Although costs of offshore wind projects are higher, there are clear indications that they can be brought down substantially through experience and economies of scale. The rewards in India have the potential to be great: a strong, steady resource that can play a major role in supplying clean energy to the major load centres in coastal cities and industrial areas within Gujarat and Tamil Nadu. Today we have the remarkable situation in Europe where all of a sudden offshore is competitive with onshore wind, and the repercussions have been felt across the world, setting the stage for a round of large investments in offshore not only in Europe, but also in Asia and North America.

With the approval of India's Offshore Wind Policy by the Union Cabinet in October 2015, the momentum for offshore wind development remains positive. It is an exciting time to explore the future of offshore wind in India and we hope you find this Grid Integration study for Offshore Wind Farm Development in Gujarat and Tamil Nadu a useful resource.



Steve Sawyer
Secretary General
GWEC



Mathias Steck
Executive Vice
President
Energy & Renewables
Advisory DNV GL



G.M. Pillai
Director General
WISE



**Dr. Anshu
Bharadwaj**
Executive Director
CSTEP



fowind
FACILITATING OFFSHORE
WIND IN INDIA

ABOUT FOWIND

The consortium led by the Global Wind Energy Council (GWEC) is implementing the Facilitating Offshore Wind in India (FOWIND) project. Other consortium partners include the Centre for Study of Science, Technology and Policy (CSTEP), DNV GL, the Gujarat Power Corporation Limited (GPCL), and the World Institute of Sustainable Energy (WISE).

The National Institute of Wind Energy (NIWE), an autonomous R&D institution under the Ministry of New and Renewable Energy, Government of India, is a knowledge partner to the project since June 2015. Renew Power Ventures Private Limited, a leading Independent Power Producer in India joined as an industry partner to the project in June 2016.

The project seeks to establish structural collaboration and knowledge sharing between the EU and India on offshore wind technology, policy and regulation and serve as a platform for promoting offshore wind research and development activities. The project focuses on the states of Gujarat and Tamil Nadu for identification of potential zones for development through preliminary resource and feasibility assessments for future offshore wind developments, as well as through techno-commercial analysis and preliminary resource assessment. The project consists of a total of seven work packages.

This Grid Integration study has been developed as part of Work Package 3. The aim of the study is to evaluate the amount of grid integrated renewable energy sources that can be reliably incorporated into the grid in regional transmission and distributions networks.



1 EXECUTIVE SUMMARY

1.1 Introduction

This report addresses the following question:

“How to prepare the state power systems to connect offshore wind projects in Gujarat and Tamil Nadu”

In response to this multi-faceted question, the report has been structured in the following subsections and sub-objectives:

1. **Policy and Industry Background** - To provide context to the report, and outline the environment under which the recommendations have been developed.
2. **Onshore Grid Development** - To address the steps necessary to prepare the physical onshore grid for integration of offshore wind projects in Gujarat and Tamil Nadu.
3. **Offshore Grid Development** - To consider what is required to facilitate (new) *offshore* grid development for the integration of offshore wind projects in Gujarat and Tamil Nadu.
4. **System Operation** - To evaluate how the states in question will ensure stable system operation with increasing penetration of offshore wind and other Renewable Energy Sources (RES).
5. **Technical and Regulatory Codes** - To review the existing suite of the most relevant codes to ensure that they are suitable for development of offshore wind projects.

1.2 Background

The growth of renewables in India has been driven by concerns over local air pollution, international climate commitments, need for energy security and the falling prices of RES. From 2007 to 2016 grid-connected Renewable Energy Sources (RES) had a Compound Annual Growth Rate (CAGR) of 21.8%. However, offshore wind remains an important untapped resource that can make an important contribution to further decarbonising India’s electricity. Offshore wind projects do not face the issues around land acquisition, typically deliver higher capacity factors compared to onshore wind and are synergistic with solar PV generation.

1.3 Onshore Grid Development

The timely development of adequate onshore transmission infrastructure is essential for connection of offshore wind generators and power evacuation from them. The grid developments are reviewed in intra-state and inter-state level to assess the capability of the power system to evacuate offshore wind power to various demand centres within the state via its intra-state system and to other demand centres outside the state. This report further investigates the relevance of the Green Energy Corridor (GEC) project and its importance to further renewable integration, especially offshore wind integration, in Gujarat and Tamil Nadu.

Gujarat Energy Transmission Corporation Limited (GETCO) and Tamil Nadu Generation and Distribution Corporation Limited (TANGEDCO) conducted power evacuation studies for integrating 500 MW of offshore wind in Gujarat and Tamil Nadu respectively by 2021-22. These study results indicate that the onshore grid infrastructure shall be adequate to evacuate offshore wind power most of the time. One of the concerns indicated in GETCO study is that offshore wind generation curtailment shall be necessary in off-peak conditions when the demand falls substantially. Under such circumstances, the power shall be exported outside the state via various inter-state transmission corridors. On the other hand, the



TANGEDCO study emphasises the requirement of timely onshore grid development to secure onshore grid connectivity and power evacuation for the proposed offshore wind generation.

Sub-Objective: Prepare the onshore grid for the integration of offshore wind		
Barrier	Mitigation	Key Stakeholder
Offshore wind not included in current grid planning scenarios	<p>Formulate state and national targets for offshore wind</p> <p>Include offshore wind development scenarios in long term planning</p>	<p>Ministry of New and Renewable Energy (MNRE), Ministry of Power (MoP)</p> <p>Central Electricity Authority (CEA), Central Transmission Utility (CTU) and State Transmission Utility (STUs)</p>
Delayed delivery of necessary onshore grid reinforcements causing power export constraints	Prioritise anticipatory investment in grid expansion (e.g. Green Energy Corridors)	CTU and STUs
Difficulty in obtaining right of way for onshore transmission infrastructures	Streamline national and state planning and permitting processes for critical infrastructure projects	Ministry of Power (MoP), State Electricity Board (SEB), CTU and STUs

1.4 Offshore Grid Development

Whilst similar in principle to onshore grids, there are several unique considerations which require a subtly different approach to planning and design of offshore grids. These are primarily centred on their relatively higher cost than onshore transmission systems, the space constraints of operating in an offshore environment as well as the specific characteristics of systems including significant quantities of offshore cable.

One must also consider the suitability of different connection technologies for different applications:

- **Medium voltage AC (MVAC)** - Relatively low CAPEX but suitable only for smaller projects closer to shore;
- **High voltage AC (HVAC)** - Moderate CAPEX including an offshore substation, suitable for larger projects up to approx. 80km from shore;
- **High voltage DC (HVDC)** - Very high CAPEX requiring offshore converter stations, suitable for very large or several grouped projects located far from shore.

The report also addresses the following different offshore grid topologies:

- **Radial** - Individual projects incrementally connected to shore via dedicated transmission lines;
- **Clustered** - Several projects sharing common, high capacity power export infrastructure;
- **Integrated/meshed** - Interconnected offshore transmission systems; their design coordinated with that of the onshore grid.



It is considered likely that the first projects in India will connect radially via MVAC or HVAC connections, however long term, as the offshore wind industry matures, this may no longer provide the optimal solution and a more centralised, strategic offshore grid planning function could be considered.

The experience from project development in Europe reveals three main regulatory models of delivery and ownership of offshore transmission assets, which are briefly discussed in the report.

- **Generator model** - Project developer builds and owns the offshore grid connection; lowers risk of stranded windfarms;
- **TSO model** - The Transmission System Operator (TSO) is responsible for delivery and ownership of the offshore grid connection; allows for coordinated development;
- **Third-party model** - Tender run to select third-party to perform these functions; de-risks projects and allows for specialisation.

Of the three models, it is considered that the first projects in India will rely on the generator model, TSO model or a hybrid of the two wherein the offshore grid connection is built by the developer and subsequently transferred to the TSO.

Such decisions have a significant bearing on the cost and feasibility of projects and there is therefore a driver to grow local capability in the planning, design and delivery of offshore transmission systems amongst key industry stakeholders and capture learning from more mature offshore wind markets in Europe.

Sub-Objective: Facilitate offshore grid development for the integration of offshore wind		
Barrier	Mitigation	Key Stakeholders
No policy exists for delivery and ownership of offshore transmission systems.	Select either generator built or TSO built model for ownership of the first offshore wind projects Initiate a Central Working Group to frame an enduring national offshore transmission policy	CEA, CTU, STUs MoP, MNRE, CEA
No framework exists for offshore transmission network planning.	Initiate a Working Group to evaluate the optimal transmission topology and system planning regime for Gujarat and Tamil Nadu.	CEA, CTU, STUs
There is limited experience in India for the planning, design and construction of offshore transmission systems.	International consultants may fill the gap in the short term. A longer-term roadmap for development of local competencies should be devised.	CTU, STUs



1.5 System Operation

Renewable generation like wind and solar are characterised by their generation variability, intermittency and lack of contribution to system inertia. Hence the large scale integration of renewables in a power system usually creates new system operational challenges like forecasting, variability management, balancing, requirement of additional reserves and ancillary services etc. This report examines various operational challenges faced by the Indian power system due to large scale renewable integration and specific operational challenges related to Gujarat and Tamil Nadu.

The common operational challenges are discussed in the wide national context:

- Frequency instability;
- Lack of generation reserves;
- Inaccurate forecasting and scheduling of renewable plants;
- Inaccuracy in load forecasting;
- Inadequate balancing sources and insufficient balancing mechanisms;
- Insufficient inter-state settlement for large scale renewable states;
- Lack of flexible market mechanisms.

A technical committee convened by Ministry of Power, with wide representation of all major stakeholders at the national and state level, has come up with a detailed national level action plan to mitigate all the above-mentioned challenges. Future renewable integration, including offshore wind, shall benefit from these action plans and hence implementation and enforcement of this action plan is necessary.

The specific power system operational challenges such as technical constraints, system balancing, forecasting and variability management, curtailment, scheduling, dispatch and deviation settlement and reserves and ancillary services are investigated in Gujarat and Tamil Nadu. Such operational challenges are common for onshore wind generation. However, offshore wind generators can positively affect the system operation (compared with onshore wind and solar), like larger size, higher capacity factor, better accuracy in generation forecasting, better reactive power control, ability to support ancillary services etc.

Sub-Objective: Ensure stable system operation with increasing penetration of offshore wind and other RES		
Barrier	Mitigation	Key Stakeholder
Incomplete/delayed enforcement of national action plan for facilitating large scale renewable integration (Section 6.3)	Rigorous follow-up and timely enforcement of identified mitigation measures	National Load Dispatch Centre (NLDC), Regional Load Dispatch Centres (RLDCs), CTU
Uncertainty around the absolute level of grid curtailment at present and expected in the near future	Measure, report and set targets on curtailment levels	Central Energy Regulatory Commission (CERC), RLDCs, State Energy Regulatory Commissions (SERCs), State Load Dispatch Centres (SLDCs)
Limited experience in system	Review the international	NLDC, RLDCs, SLDCs



Sub-Objective: Ensure stable system operation with increasing penetration of offshore wind and other RES		
operation with increased penetration of RES	<p>practices and implement knowledge exchange/ capacity building programs to fulfil the gaps in the short term</p> <p>Long term roadmap for development of local competencies</p>	

1.6 Technical and Regulatory Codes

This report examines three key codes and processes which are crucial to the development of any generation project and specifically offshore wind.

- **Connection Application Process**

Given that the grid connection process has not evolved with offshore wind in mind, there are likely to be elements of the current process which should be clarified for the purposes of offshore wind projects, particularly:

- Application format and requirements for data and documentation should be reviewed considering offshore wind applications;
- Processing timescales may be challenging for complex offshore connection requests;
- The application change process must be flexible to accommodate the expected refinement in offshore project capacity through the development process;
- The timescales for onshore grid reinforcement following grant of Long Term Access (LTA) may not align with the development timeframe of an offshore wind generator and any delays could be significant.

- **Grid Code**

The technical requirements in the Grid Codes for connection to the Grid were reviewed for their relevance to offshore wind projects and compared to similar codes in jurisdictions with mature offshore wind markets (namely Germany and the United Kingdom). In principle, the Indian Grid Code is consistent with the German and UK codes and modern offshore wind turbines are capable and flexible machines therefore the Grid Code is not perceived as a barrier to offshore wind development. That said, the introduction of more stringent requirements on RES, particularly strict frequency control requirements in the current draft amendment requiring a 10% response within 1 second may be challenging to meet via conventional means.

- **System Reliability Standards**

The applicability of the current transmission planning criteria with respect to offshore wind integration is reviewed. The current criteria do not consider offshore wind generation and hence proper attention shall be paid to certain factors that distinguish offshore wind connections from onshore wind/ solar connections. Proper attention shall be paid to the geography and ownership of offshore systems and its onshore interface points, risks associated with radial connection,



criteria on reliability and security etc. A case study from the UK for inclusion of offshore wind generation in their Security and Quality of Supply Standards (SQSS) is provided.

Sub-Objective: Ensure technical and regulatory codes are suitable for offshore wind projects		
Barrier	Mitigation	Key Stakeholder
The connection process does not specifically address offshore wind projects.	Publish guidance on connection application process for the first offshore windfarms.	CTU, STUs, CERC, SERCs
Grid codes do not specifically address specific characteristics of offshore wind and its transmission connection	<p>Future code modifications should be reviewed considering the specific characteristics and installed capacity of power from offshore wind farms.</p> <p>Review the need for a separate grid code or modifications specifically for offshore wind projects.</p> <p>Clarification on the compliance boundary of OWF under individual grid code requirements</p>	CEA, CTU, STUs, CERC, SERCs
Planning standards do not address reliability standards for offshore connections.	Clarify on the applicability of present planning standards and consider the need for an offshore specific set of planning standards.	CEA, CTU, STUs

1.7 Summary

One of the identified challenges for offshore wind development in Gujarat and Tamil Nadu is the integration of electricity generated by offshore wind farms. In preceding sections, twelve practical recommendations have been formulated to address these challenges and facilitate offshore wind development in Gujarat and Tamil Nadu.

These can be viewed within four overarching 'themes' that should be addressed by government and industry stakeholders if a successful offshore wind industry is to be built.

I. Delivery of Existing RES Action Plans

A number of major initiatives are underway (notably the GEC and National Action Plan for Large Scale Integration of Renewable Energy). These initiatives will certainly facilitate the grid integration of offshore wind, reducing delivery and curtailment risks, and should be reviewed considering any specific policy targets for build-out of offshore wind projects. However, a failure



to achieve these existing roadmap goals will likely have a detrimental impact upon the development of a larger, successful offshore wind industry in India.

II. Offshore Wind Policy and Code Development

The following gaps in policy and code frameworks have been identified, and guidance on the treatment of initial, pilot, offshore wind projects would be beneficial as well as a wider policy and code review considering future industry growth scenarios.

- Lack of clear offshore wind build-out targets to enable state and national infrastructure planning for offshore wind.
- The lack of a framework for delivery and ownership of offshore grid systems to connect offshore wind.
- A lack of specific treatment of offshore wind in technical and regulatory codes and processes.

III. Grid Development Planning

Grid integration studies have been performed on behalf of the FOWIND consortium by both GETCO and TANGEDCO for integration of an initial 500MW offshore wind project. However, should larger volumes of offshore wind be planned, further strategic grid development studies will be necessary to identify possible transmission bottlenecks to wider integration of offshore wind. Furthermore, it would be beneficial to review the general approach to grid development and planning to ensure that offshore and onshore grid development proceeds in a manner which ensures secure, stable and economically viable onshore and offshore grid development.

IV. Competence and Capability Development

Lessons have been learnt in offshore grid development internationally and it will be important that these lessons are applied in an Indian context to de-risk delivery of critical offshore infrastructure. International consultants with experience from mature markets may fill the gap in the short term, but over the long term the development of strong local offshore design, planning and construction capabilities will be beneficial; as well as capturing learning from international TSOs with experience operating systems with high RES penetration.



2 INTRODUCTION

2.1 FOWIND Project Background

The consortium led by the Global Wind Energy Council (GWEC) is implementing the Facilitating Offshore Wind in India (FOWIND) project. Other consortium partners include the Centre for Study of Science, Technology and Policy (CSTEP), DNV GL, the Gujarat Power Corporation Limited (GPCL), and the World Institute of Sustainable Energy (WISE).

The National Institute of Wind Energy (NIWE), an autonomous R&D institution under the Ministry of New and Renewable Energy, Government of India, is a knowledge partner to the project since June 2015. Renew Power Ventures Private Limited, a leading Independent Power Producer in India; joined as an industry partner to the project in June 2016.

The project seeks to establish structural collaboration and knowledge sharing between the EU and India on offshore wind technology, policy and regulation and serve as a platform for promoting offshore wind research and development activities. The project focuses on the states of Gujarat and Tamil Nadu for identification of potential zones for development through preliminary resource and feasibility assessments for future offshore wind developments, as well as through techno-commercial analysis and preliminary resource assessment. The project consists of a total of seven work packages.

This Grid Integration study has been developed as part of Work Package 3. This report addresses the following question on *how to prepare the state power systems to connect offshore wind project in Gujarat and Tamil Nadu?*

2.2 Report Purpose

At the highest level, this report will seek to address the following question:

“How to prepare the state power systems to connect offshore wind projects in Gujarat and Tamil Nadu”

In response to this multi-faceted question, the report has been structured in the following subsections and sub-objectives:

1. **Policy and Industry Background:** To provide context to the report, and outline the environment under which the recommendations have been developed.
2. **Onshore Grid Development:** To address the steps to prepare the physical onshore grid for integration of offshore wind projects in Gujarat and Tamil Nadu.
3. **Offshore Grid Development:** To consider what is required to facilitate (new) *offshore* grid development for the integration of offshore wind projects in Gujarat and Tamil Nadu.
4. **System Operation:** To evaluate how the states in question will ensure stable system operation with increasing penetration of offshore wind and other Renewable Energy Sources (RES).
5. **Technical and Regulatory Codes:** To review the existing suite of the most relevant codes to ensure that they are suitable for development of offshore wind projects.

This report will assess the current status-quo of industry development in these subject areas, at a state level and nationally (as applicable), as well as existing initiatives, and identify any remaining barriers specific to the integration of offshore wind projects into the Grid. To address these barriers additional measures will be recommended to facilitate connection of offshore wind farms in Gujarat and Tamil Nadu.

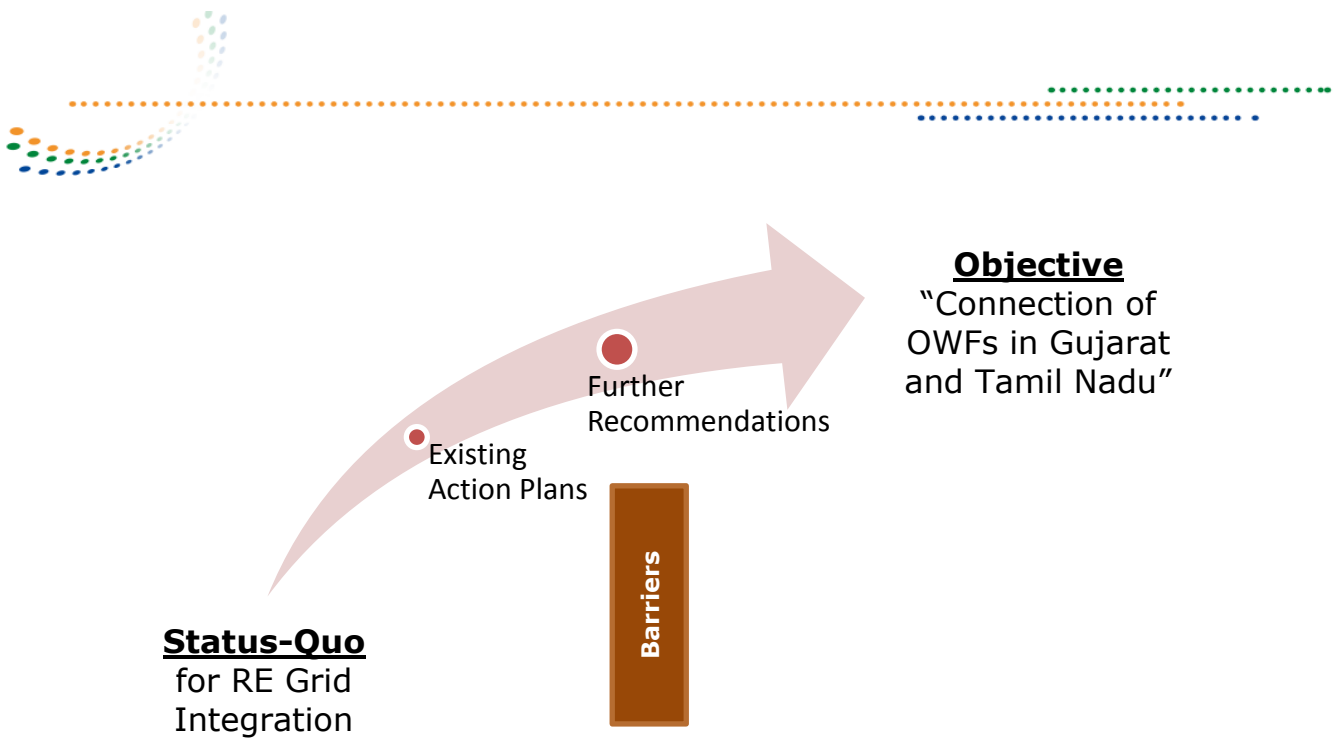

2.3 Report Scope

This report solely addresses the integration of offshore wind farms in Gujarat and Tamil Nadu. Other RES will only be addressed in as much as they interact with this over-arching objective. Similarly, no additional states within India are considered and national frameworks and infrastructure planning will be assessed only where it impacts the potential build-out of offshore wind projects in these states.

Whilst this report nominally considers the time period 2020-2032, it does not make assumptions regarding the build-out rate of offshore wind or attempt to assert a policy framework which is not yet established.

The principle audience is for this report is:

- Power system planners;
- Technical Regulatory Bodies;
- Grid Operators;
- Potential Developers of Offshore Renewable Power Projects.

It is not intended as a detailed, technical “how to” but rather to supplement grid integration planning and design with a high level ‘readiness’ assessment with recommendations.



3 POWER SECTOR SCENARIO

The electricity sector in India is expanding at a rapid pace, with evolving market dynamics, generation and transmission capacity addition and rapid electricity distribution expansion. Large quantities of renewables are expected to be integrated in the transmission and distribution networks. This section summarises the power sector situation in India and the role of renewables in the evolution of a low carbon power sector. The importance of offshore wind generation as a part of the robust growth of the renewable sector is discussed. The power sector situations in states of Gujarat and Tamil Nadu are briefly discussed. The later part of this section summarises the key stakeholders in the power sector in the context of grid development, operation, and regulation. The objective is to provide a general background regarding the power sector in India in relation to facilitating offshore wind integration into the Gujarat and Tamil Nadu power systems.

3.1 Policy Background

India's annual per capita electricity consumption in the Financial Year (FY) 2015-16 was 1,075 kWh, up 70% from FY 2005-06 [1]. However, this is still significantly lower than the 2013 global average of 3,100 kWh [2]. Driven by this low base and projections of continued economic growth, the country's electricity demand is projected to follow a Compound Annual Growth Rate (CAGR) of 6.34 – 8.34% to 2022 [3]. Long term studies forecast that India will account for 17% of the increase in global electricity demand till 2040 [4]. This capacity addition presents a unique opportunity to shape a clean, reliable and affordable power sector.

As of January 2017, the installed capacity of Renewable Energy Sources (RES) was 50GW, or 15.9% of total capacity [5]. Small hydro projects (≤ 25 MW) are included under RES.

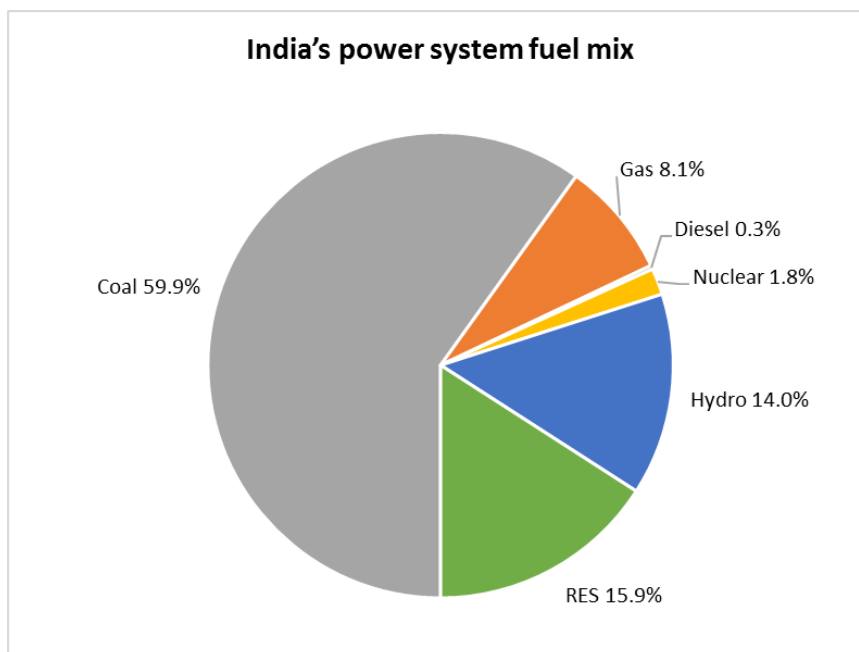

Figure 1: India's power system fuel mix

Installed RES capacity grew slowly from 1985 to 2007. From 2007 to 2016 grid-connected RES has a CAGR of 21.8% and also contributed a greater share of the total installed capacity.

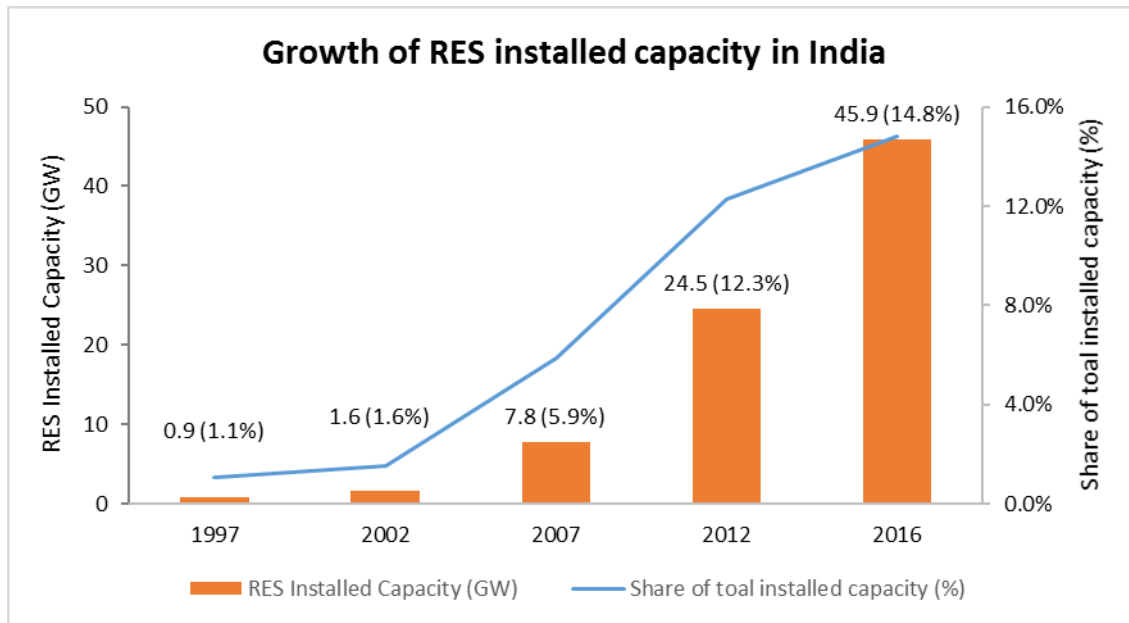

Figure 2: Growth of RES installed capacity in India (R2)

The Central Electricity Authority (CEA) forecasts that RES capacity will grow to 175GW by 2022 and further to 275GW by 2027 to make up 43% of the installed generation capacity [3]. This would represent a six-fold increase in RES capacity in the eleven year period to the end of 2027.

The growth of renewable energy in India, and more broadly worldwide, is driven by a number of local and international drivers as outlined below.

Local air pollution: The current reliance on fuel burning for energy supply is a leading cause of growing concerns over local air pollution that has gained wide media coverage in recent years. Continued exposure to elevated levels of particulate matter and ozone leads to chronic pulmonary disease, premature mortality and has also been linked to reduced agricultural yields [6], [7].

International commitments: The expansion of renewable power generation is one of the goals of India's commitment at the Paris COP. The Intended Nationally Determined Contribution (INDC) submission aims to have 40% of the installed power generation capacity to be non-fossil fuel based by 2030. A second goal of the INDC is to reduce the 2030 emissions intensity of GDP by 33 to 35% from 2005 levels [8]. Decarbonisation of the power sector will play a significant role in the decarbonisation of the overall economy because low carbon electricity can reduce end-use sector emissions in households, transport and industry through greater electrification [9].

Energy security: Renewable energy is also appealing to policymakers as a means to ensure long term energy security. Despite, the recent focus on increased local coal production, India remains a net importer of fossil fuel. A greater share of renewable energy (assuming it is not imported) in primary energy supply, reduces the risk of supply disruptions and insulates the economy from the consequences of unpredictable volatility in international fossil-fuel prices.

Falling prices: Finally, the growth of renewables is being driven by the rapid decline in prices. The global weighted average installed cost for onshore wind declined from approximately € 4440/kW in 1983 to around € 1450/kW in 2015, which is an overall reduction of more than two-thirds during this time period [10]. In February 2017, India's first auction for onshore wind allocated four project developers with 250MW capacity each at a tariff of INR 3.46 (€ 0.050)/kWh. In the same month, the auction for a 750MW solar project closed at a levelised tariff of INR 3.29 (€ 0.047)/kWh. These prices compare



favourably with prices paid by distribution companies to procure power from central government owned generating companies in 2015-16 under long-term Power Purchase Agreements (PPAs)¹ [11].

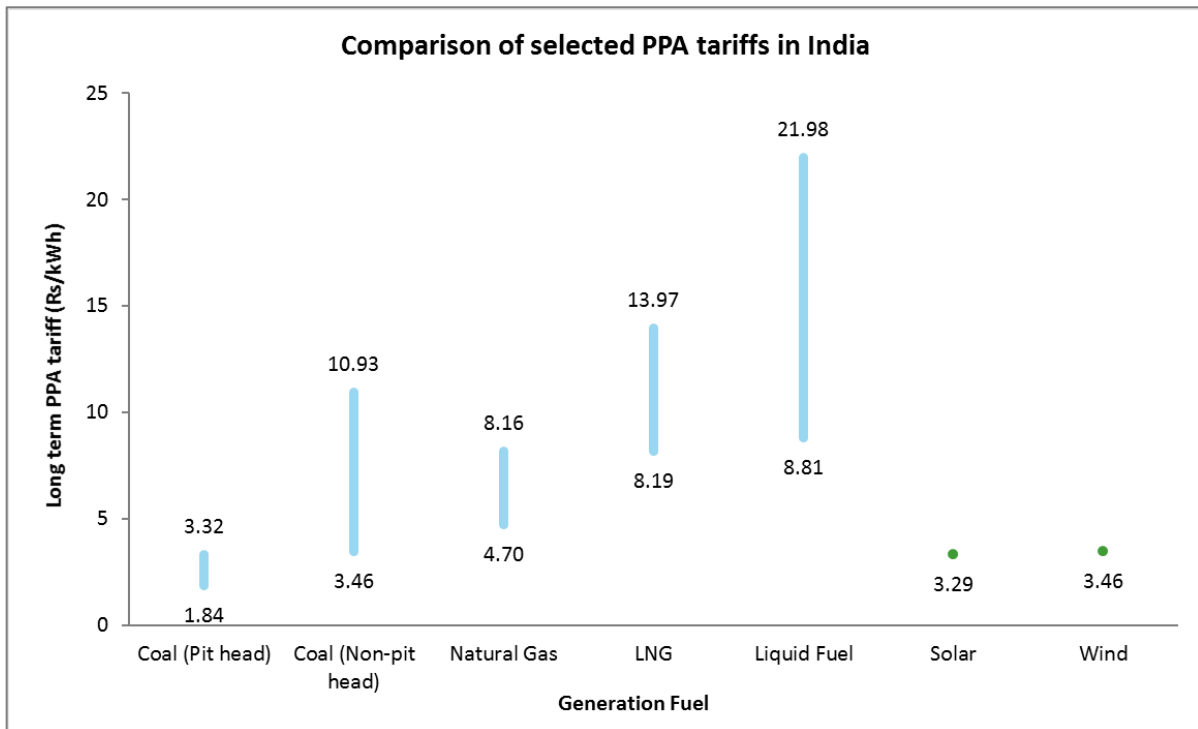

Figure 3: Comparison of selected PPA tariffs in India (R3)

A further reduction in RES costs in India can be expected as the supply chain benefits from economies of scale, changes in regulatory framework, and greater political will.

Solar and wind have been the two areas of strong RES growth in India. Wind power to date has all been onshore wind, resulting in India having the world's fourth largest installed capacity (28.7GW) by the end of 2016 [12]. The global offshore wind installed capacity exceeded 14GW by the end of 2016 with the UK, Germany and the PR China leading the way [12]. As a first step to tap this resource, the National Offshore Wind Energy Policy was approved in September 2015 [13]. It lays out in broad terms the roles of the nodal ministry (MNRE) and the appointed nodal agency, National Institute of Wind Energy (NIWE). While the policy briefly addresses the provision of onshore infrastructure for evacuating the power generated by offshore wind farms, no mention is made of the offshore grid connections required.

In February 2015, MNRE set a target of RES installed capacity of 175GW by 2022. This is broken down in to 100GW of solar, 60GW wind, 10GW biomass and 5GW small hydropower. This target is a significant step-up up from the 2010 policy aim of 20GW of grid connected solar power by 2022 [14]. The policy trend of increasing renewable energy ambitions and the rapid decline in costs are reasons to expect that the RES capacity goals may be further revised upwards in the next 5 years.

Offshore wind offers three main benefits over solar PV and onshore wind projects, in addition to providing the benefits of RES. First, offshore wind projects do not face the development phase hurdle of land acquisition, which has recently stalled power projects in India [15], [16]. Second, offshore wind typically delivers higher capacity factors compared to onshore wind because the average annual wind speeds at sea are higher than those on land. Third, offshore wind and solar PV are synergistic RES

¹ For conventional generation, the tariffs shown is the total tariff, i.e. fixed charges + energy charges. For solar and wind, only the most recent auction prices are shown.



because the seasonal and daily production cycles tend to be complementary [17]. This is particularly important in the case of India, where solar PV is targeted to reach 100GW of installed capacity by 2022.

There exist several challenges in enabling robust growth of offshore wind farms in India. One such barrier is ensuring that the transmission grid is prepared to integrate the electricity generated from offshore wind farms. In the absence of this, offshore wind farms are likely to face curtailment events, i.e. the wind farm was able to generate electricity but was not allowed to export the power to the grid. Curtailment events can lead to a significant reduction in the potential energy (not) produced. Curtailment events prevent the efficient use of clean energy and also create uncertainty for future investment in renewable assets.

Renewable electricity generation has a very important role in India's future electricity supply. Solar and onshore wind have been the current focus of policymakers and have seen strong growth over the last decade. Offshore wind can play a complimentary role to these technologies by adding to the diversity of supply, providing a higher capacity utilisation factor and possibly freeing up land for other uses. The offshore wind resource potential can make a major contribution to expanding supply of clean electricity to solve pressing issues of improving local air quality, reducing global climate disruption, and strengthening national energy security.

3.2 Key Stakeholders of Indian Power Sector

The central Ministry of Power (MoP) is primarily responsible for the development of electrical energy in the country and development of power system planning, policy formulation, processing of projects for investment decisions, monitoring the implementation of power projects, training and manpower development, and the administration and enactment of legislation regarding thermal, hydro power generation, transmission, and distribution [18]. Central, state, and private players develop the generation and transmission sectors, while state and private players mainly develop the distribution sector. The development and deployment of renewable energy is governed by the Indian Ministry of New and Renewable Energy (MNRE).

Various stakeholders in the Indian power sector are summarised in Figure 4.

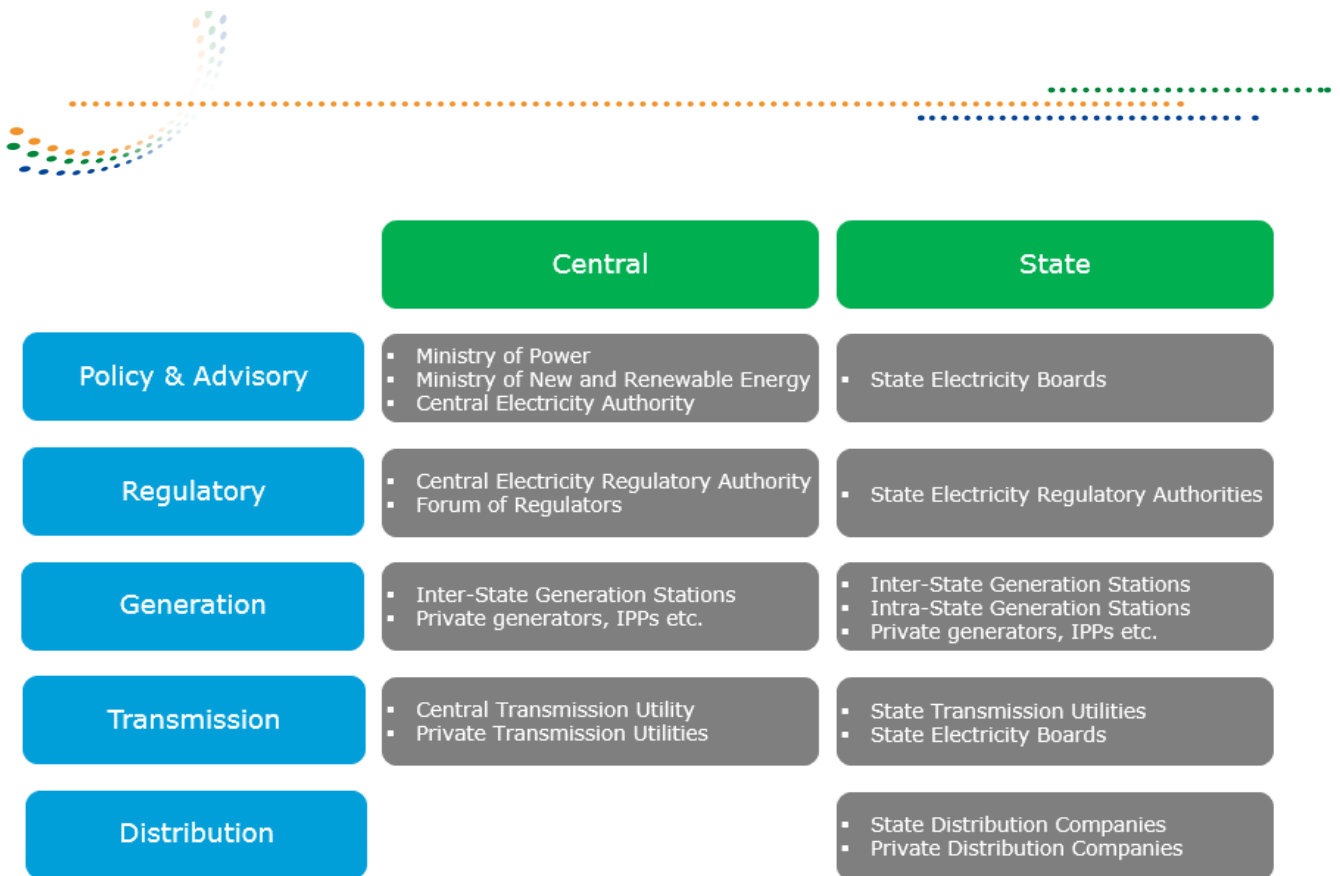

Figure 4: Stakeholder overview in Indian power sector

The Indian power system is divided into five separate zones [North, East, North East, West, and South]. All the zones are interconnected synchronously and operating as a single grid.

The Central Transmission Utility (CTU)- PGCIL (Power Grid Corporation of India Limited)- is responsible for development of Inter-State Transmission System (ISTS) that is in coordination with the planned generation capacity addition while also facilitating inter-regional and inter-state exchange of power. The State Transmission Utilities (STU) and State Electricity Boards (SEB) govern the development of intra-state transmission system (Intra-STS). In recent times, private players have ventured into the transmission sector. Regional Power Committees (RPC), have been constituted in each of the 5 regions in order to facilitate the stability and smooth operation of the integrated grid and efficiency in the operation of the power system in the respective regions. At present the transmission grid is operated in various voltage levels at ± 800 kV (HVDC), 765 kV, ± 400 kV (HVDC), 400 kV, 230/220 kV, 132 kV, 110 kV, and 66 kV.

Power generation is facilitated through central government owned entities, state government owned entities, and independent power generators in private sector. The central government owned entities include National Thermal Power Corporation (NTPC), National Hydro Power Corporation (NHPC), Nuclear Power Corporation of India (NPCIL) and these act as inter-state generating stations. The intra-state generating stations are owned by respective state electricity boards or state generation companies and essentially serve the intra-state loads. The independent power producers can connect either to the intra-state or inter-state transmission system.

The distribution sector is typically owned by state-owned distribution companies as well as a few privately-owned distribution companies.

Power system operation is governed by different apex bodies at different hierarchical levels. National Load Dispatch Centre (NLDC) ensures the integrated power system operation in the country and is supported by a Regional Load Dispatch Centre (RLDC), which ensures the smooth power system operation in the region. The NLDC and RLDCs form a part of the Power System Operation Corporation



Limited (POSOCO), which is a wholly owned subsidiary of PGCIL (the CTU). The State Load Dispatch Centres (SLDCs) are responsible for power system operation in the respective states and comply with the directions of the RLDC. The SLDCs fall under the jurisdiction of state government. Figure 5 shows the pictorial representation of the operation hierarchy.

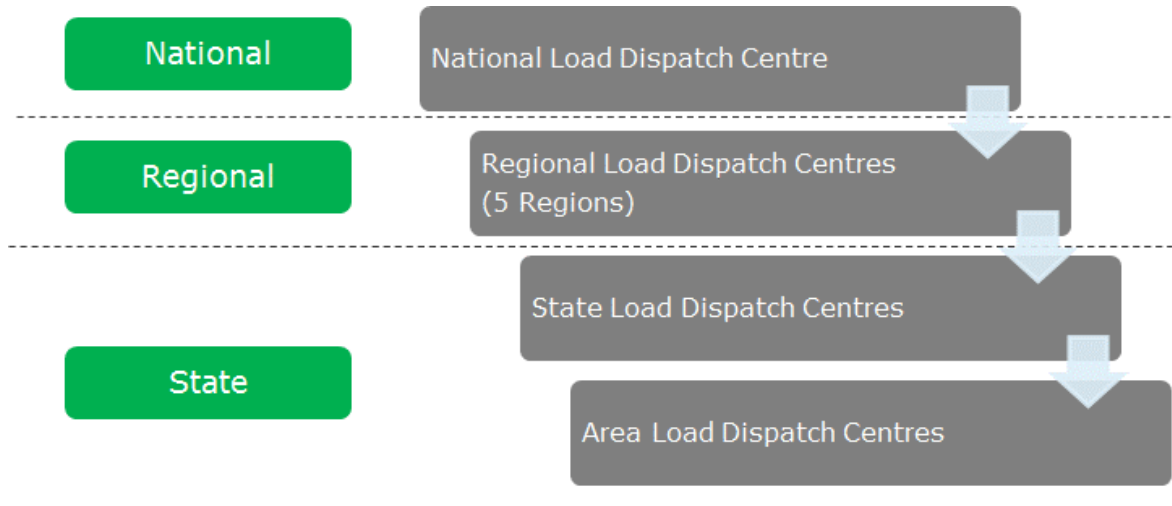

Figure 5: Stakeholders in Indian power system operation

3.3 Overview of Gujarat Power Sector

Gujarat has an installed generation capacity of 29.9 GW which includes 5.2 GW of renewables, as of March 2016 [3]. The thermal power plants (including coal and gas) constitute the major contribution of installed capacity, followed by renewables.

The state of Gujarat is strategically located with a plentiful supply of wind and solar resources. The National Institute of Wind Energy (NIWE) estimates 88.4 GW wind power potential at a hub height of 100 m in the state and this is the highest figure among other states in India [19]. The estimated solar energy potential is about 36 GW [19]. The renewable energy capacity is poised to increase from the current level of 5.2 GW (March 2016) to 17.1 GW by the end of 2021-22 under GoI's ambition for a national target of 175 GW renewables by 2021-22 [3].

The peak electricity demand was 14.5 GW by end of 2015-16 and is projected to increase to 21.5 GW by the end of 2021-22 and projected to grow around 20% on annual basis. Meanwhile, installed generation capacity is projected to be at 47.7 GW compared to the current level of 29.9 GW (March 2016). By 2021-22, the combined capacity of wind and solar generation will be around 43% of the total installed generation capacity. Although further capacity increase in the thermal sector is expected, the total percentage of thermal generation in the installed generation mix will be down to around 50% from the current level of around 71% by 2021-22. Figure 6 to Figure 8 shows the growth in total generation and peak demand, installed generation capacity, and installed renewable capacity projected to the 2021-22 period [3], [20].

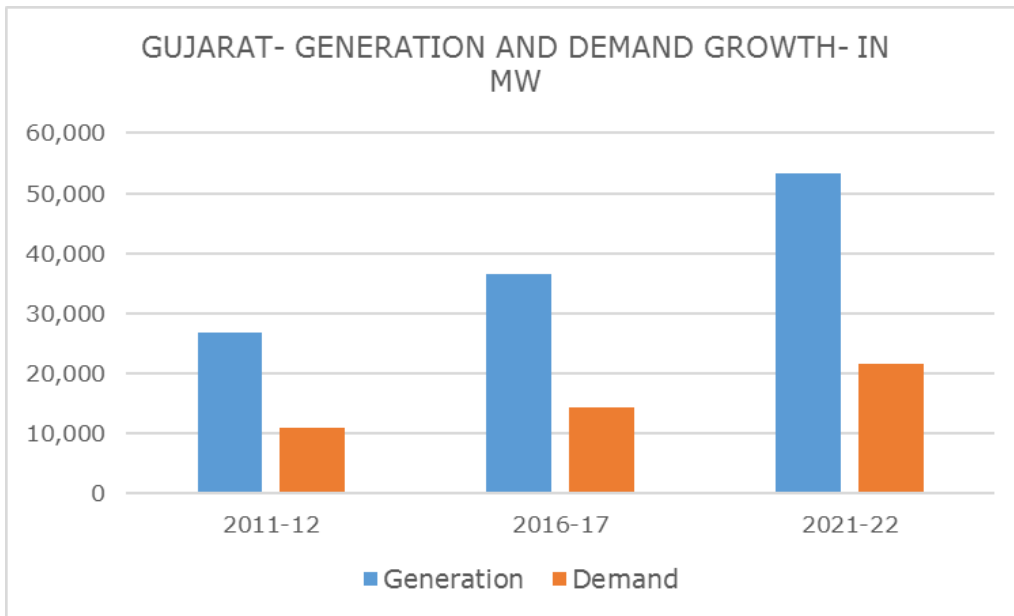

Figure 6: Growth of generation and peak demand, Gujarat

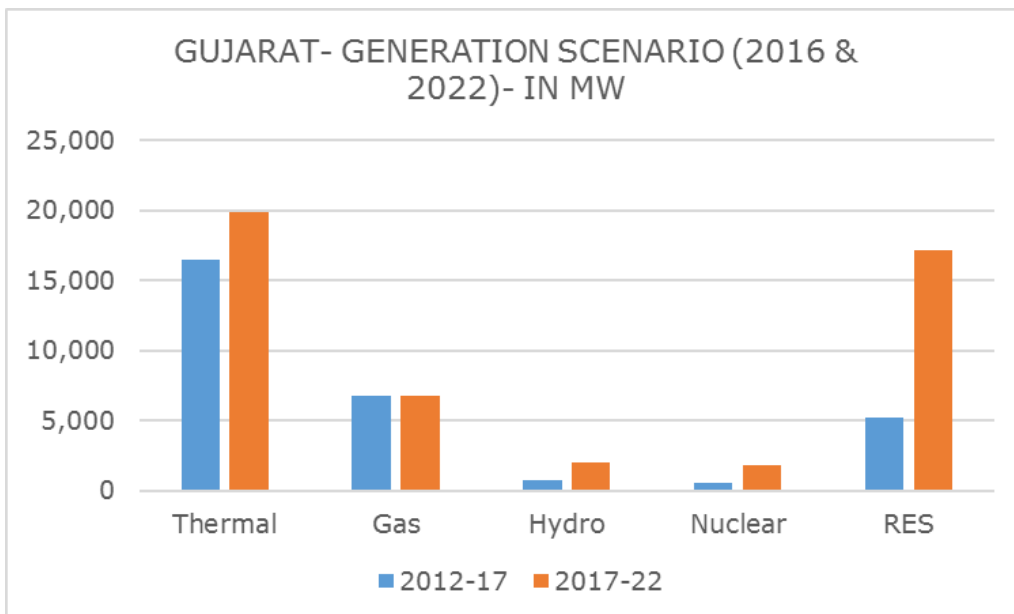

Figure 7: Generation growth scenario, Gujarat

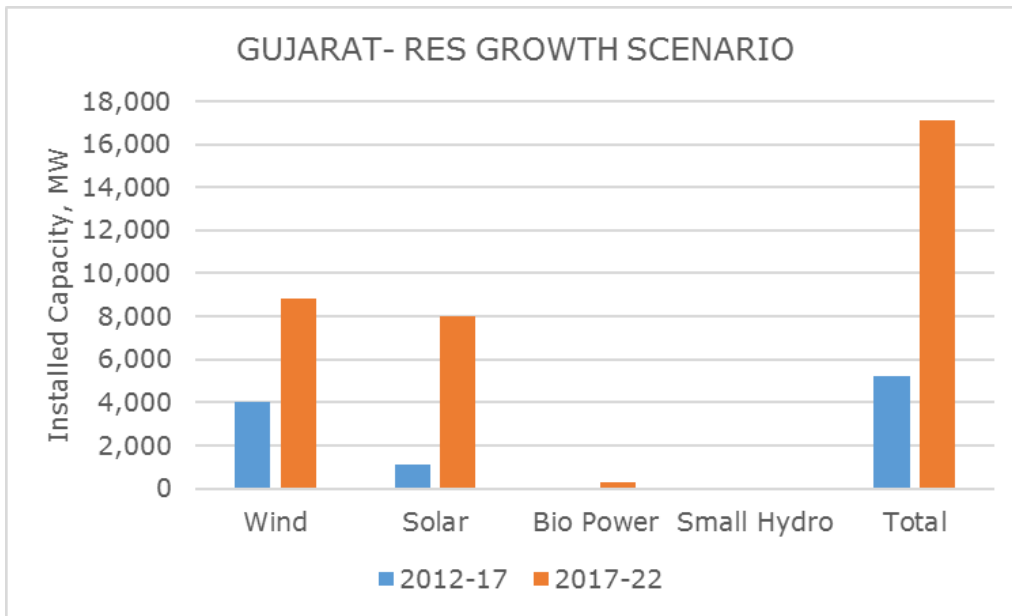

Figure 8: Renewable growth scenario, Gujarat

3.3.1 Key Stakeholders in Gujarat Power Sector

The key stakeholders in Gujarat Power Sector are listed in Table 1.

	Key Stakeholder
Policy	Gujarat State Electricity Board
Regulatory	Gujarat Energy Regulatory Commission
Generation	Gujarat Power Corporation Limited (GPCL)
Transmission	Gujarat Electricity Transmission Company (GETCO)
Distribution	Dakshin Gujarat Vij Corporation Limited Madhya Gujarat Vij Corporation Limited Purva Gujarat Vij Corporation Limited Utara Gujarat Vij Corporation Limited
Grid Operation	Western Region Load Dispatch Centre (Regional) Gujarat State Load Dispatch Centre (State)

Table 1: Key stakeholders in Gujarat Power Sector

3.4 Overview of Tamil Nadu Power Sector

Tamil Nadu has an installed generation capacity of 25.4 GW which includes 9.5 GW of RES generation, as of 31st January 2017. The state has a total of 13.3 GW of thermal generation in the form of coal, gas, and diesel, 2.2 GW of hydro, and around 1 GW of nuclear generation [3]. At present, Tamil Nadu is the only state where more than one-third of the installed capacity is RES.



Tamil Nadu has further significant wind and solar power potential. NIWE estimates 33.8 GW of wind power potential at a hub height of 100 m in the state [19]. The estimated solar energy potential is about 18 GW. By 2021-22, the state is targeted to grow to 21.5 GW of renewables, with 11.9 GW of wind and 8.9 GW of solar.

The peak electricity demand is expected to grow from 14.2 GW by end of 2015-16 to 21.8 GW by end of 2021-22, with around 11% growth on an annual basis. Meanwhile, installed generation capacity is projected to be at 49.7 GW from the current level of 25.4 GW (March 2016). By 2021-22, the combined capacity of wind and solar generation will be around 44% of the total installed generation capacity which is a growth from the current level of 28.3%. The percentage of thermal generation in total installed capacity is projected to be 45.8% from the current level of 56.4% [3], [20]. Figure 9 to Figure 11 shows the growth in total generation and peak demand, installed generation capacity, and installed renewable capacity projected to the 2021-22 period.

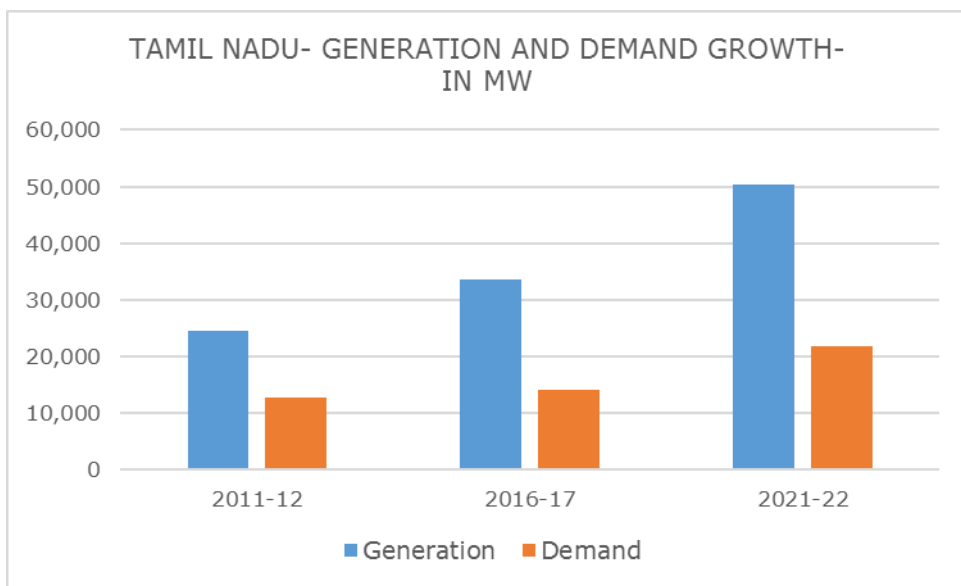

Figure 9: Generation and peak demand growth scenario, Tamil Nadu

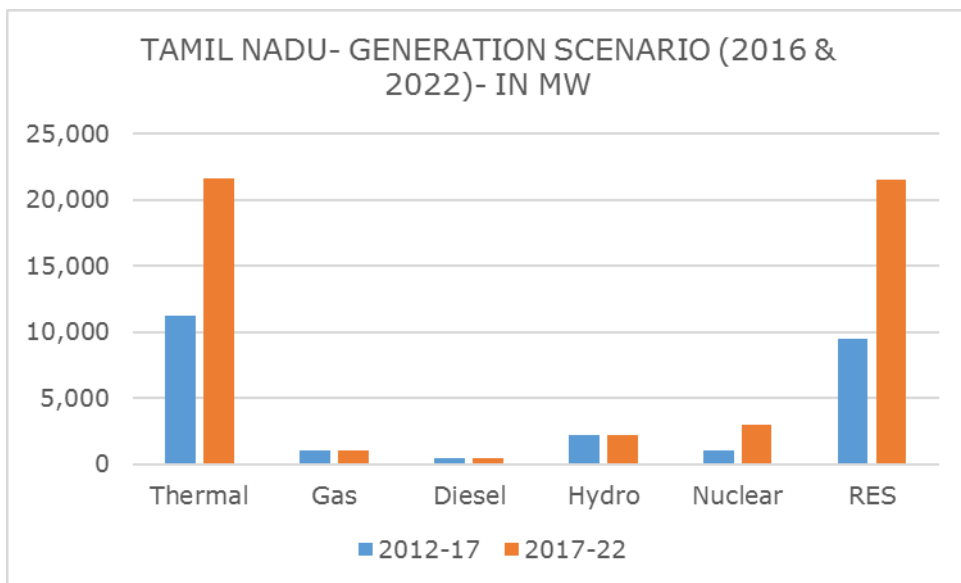

Figure 10: Generation growth scenario, Tamil Nadu

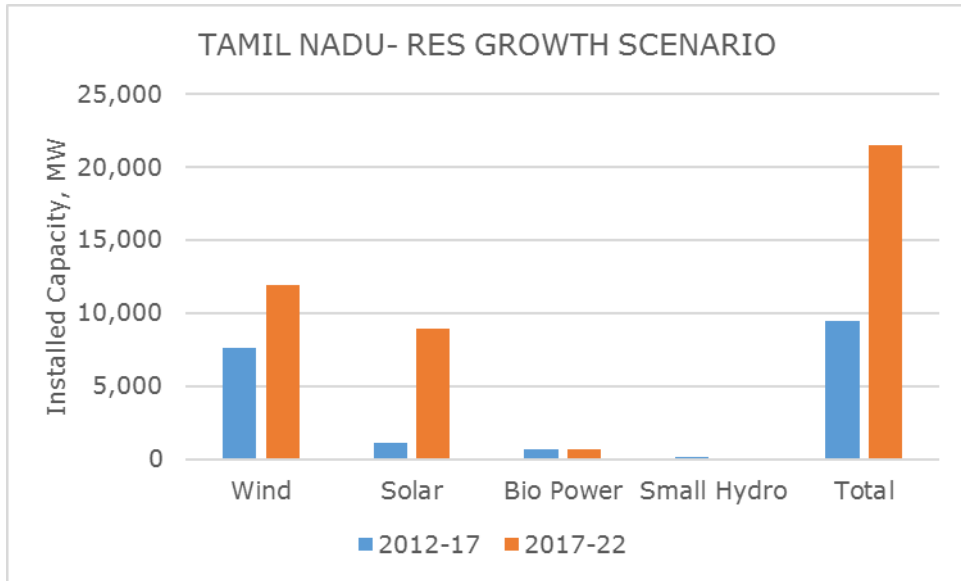

Figure 11: Renewable growth scenario, Tamil Nadu

3.4.1 Key Stakeholders in Tamil Nadu Power Sector

The key stakeholders in the Tamil Nadu power sector are listed in Table 2.

	Key Stakeholder
Policy	Tamil Nadu State Electricity Board
Regulatory	Tamil Nadu Energy Regulatory Commission
Generation	Tamil Nadu Generation and Distribution Company (TANGEDCO)
Transmission	Gujarat Electricity Transmission Company (GETCO)
Distribution	Tamil Nadu Generation and Distribution Company (TANGEDCO)
Grid Operation	Southern Region Load Dispatch Centre (Regional) Tamil Nadu State Load Dispatch Centre (State)

Table 2: Key stakeholders in Tamil Nadu Power Sector



4 ONSHORE GRID DEVELOPMENT

India's target of 175GW by 2022 is mainly aimed at onshore wind and solar capacity addition in various wind and solar rich states. However, the long coastline and offshore wind resource provides an opportunity to exploit offshore wind energy. The onshore grid infrastructure must be adequately planned and developed to accommodate the offshore wind energy (delivered through offshore grid system) and evacuate it. Section 5 of this report focuses on offshore wind integration in Tamil Nadu and Gujarat and reviews the preparedness of the grid infrastructures in these two states to offtake the power from the offshore wind farm(s) and to evacuate the power to various load centres via intra-state and ISTSs. The relatively larger sizes of offshore wind farms and their higher capacity factors indicate that grid infrastructure in regional and national level shall be adequately prepared to evacuate the power out of the state if the host states cannot consume the power within the intra-state system. Hence this section briefly reviews the regional and national level grid developments which could impact the possible offshore wind capacity additions. The key delivery risks are identified and recommendations are proposed for addressing key barriers for smooth integration of offshore wind power.

4.1 Overview of Existing Grid Infrastructure in National Level

The national grid consists of the transmission system for evacuation of power from generating stations, the inter-regional links, ISTSs, and the Intra-STSs. This is a large, meshed synchronous system where five regional grids are connected synchronously and operate at a common frequency. Tamil Nadu is part of Southern grid, which consists of the states of Andhra Pradesh, Karnataka, Kerala, Tamil Nadu, Telangana and the union territory of Puducherry. Gujarat is part of Western grid, which consists of the states of Chattisgarh, Goa, Gujarat, Madhya Pradesh, Maharashtra, and the union territories of Daman and Diu and Dadar and Nagar Haveli.

The power network map of national grid, southern grid, and western grid are given in Figure 12, Figure 13 and Figure 14 respectively[21].

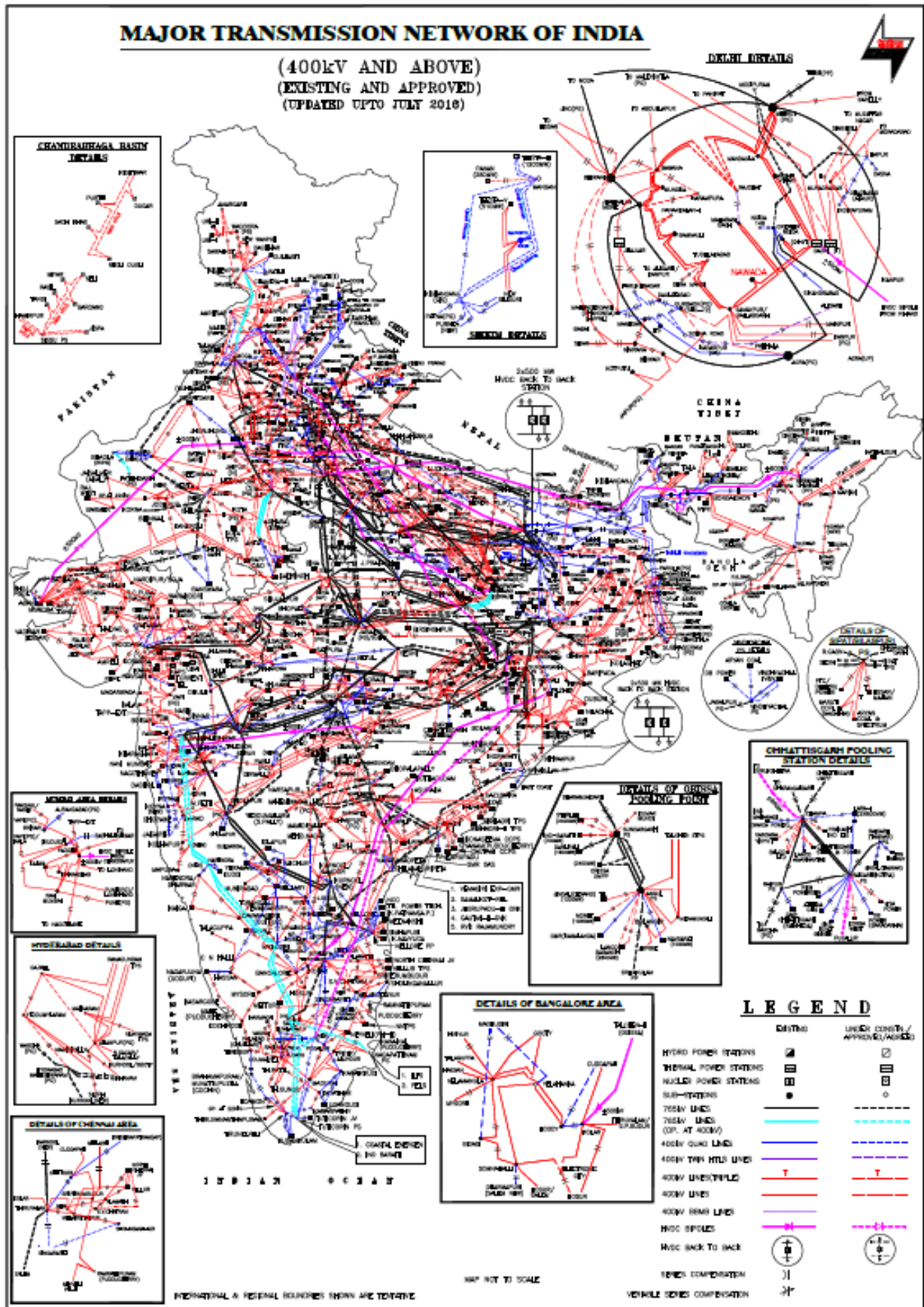

Figure 12: Major transmission network map, India

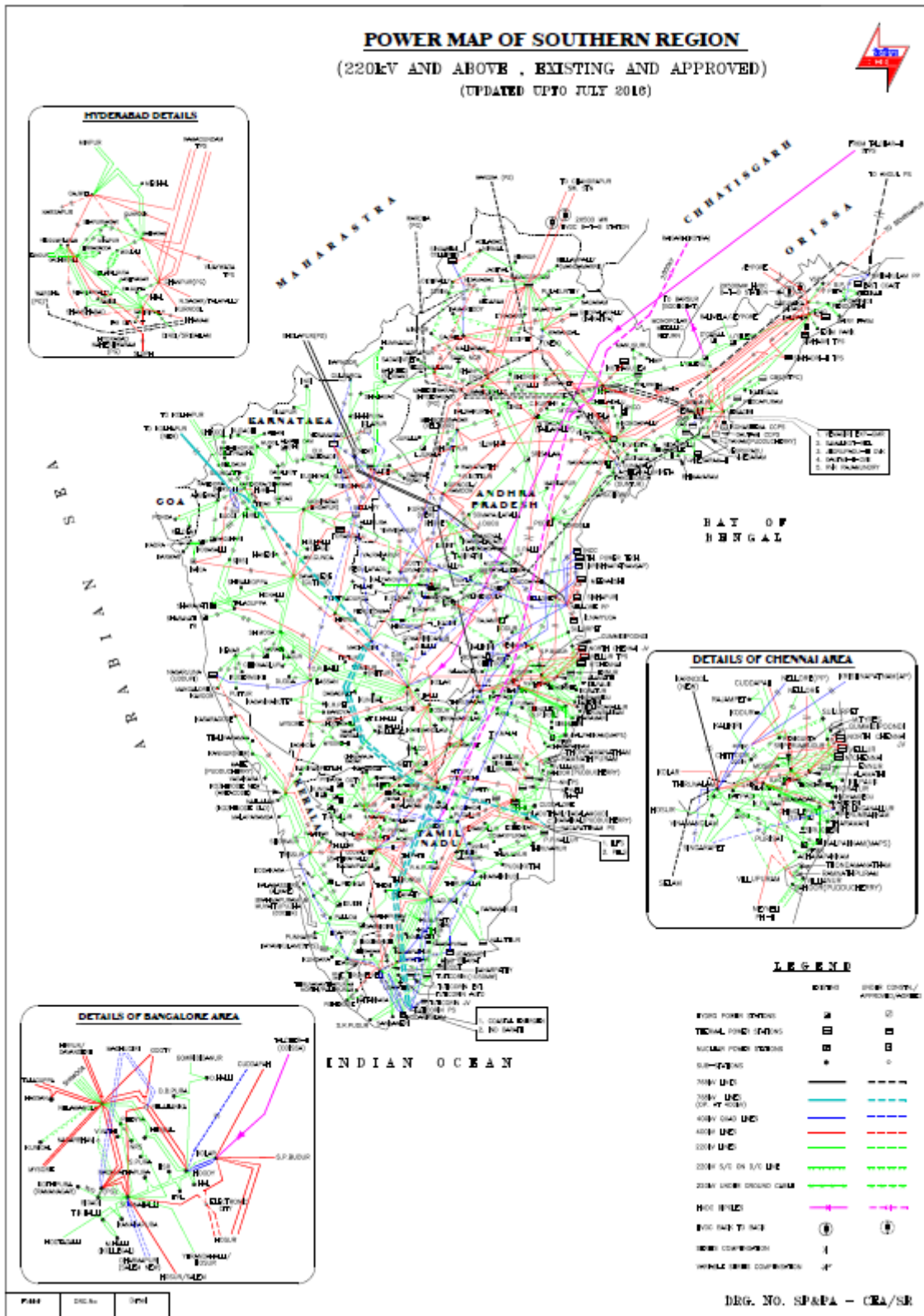

Figure 13: Major transmission network map, Southern region

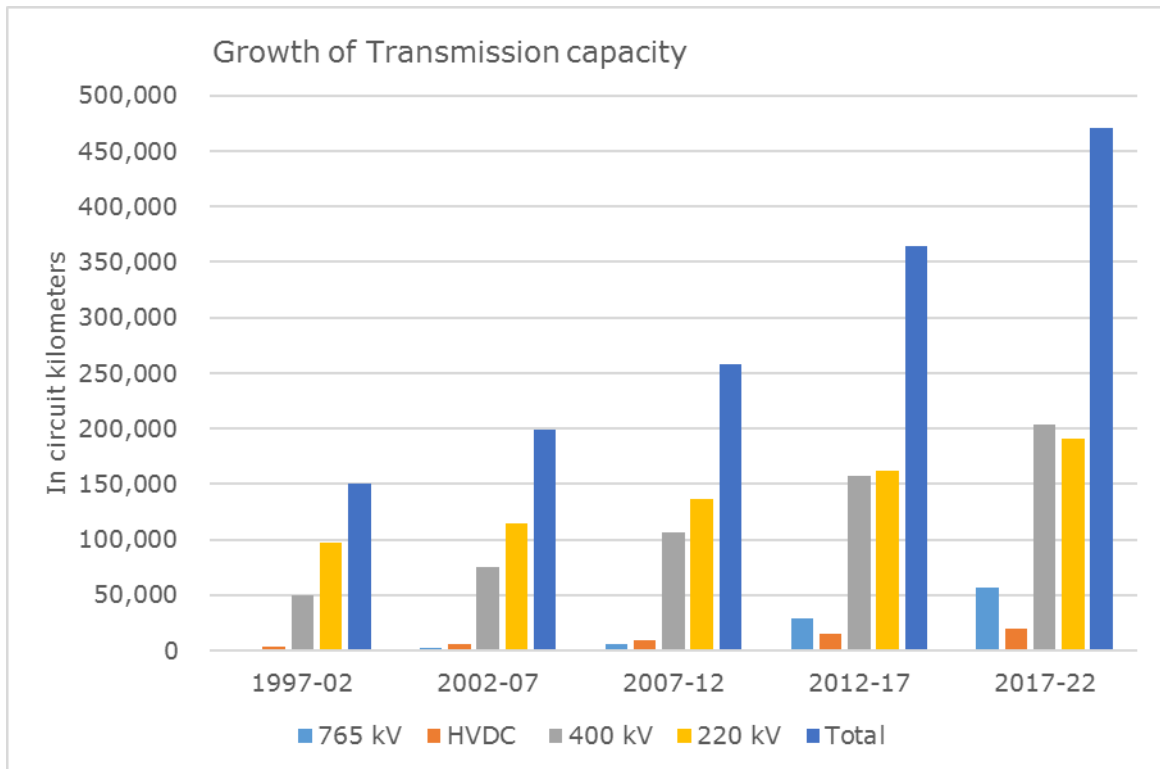

Figure 15: Growth of transmission line capacity (in circuit kilometres)

Similarly, the cumulative growth in transformation capacity at voltages of 220 kV and above in past planning periods and projected growth in the coming planning period (include projected capacities for 2012-17 and 2021-22) are summarised (in terms of MVA) in Figure 16 [20].

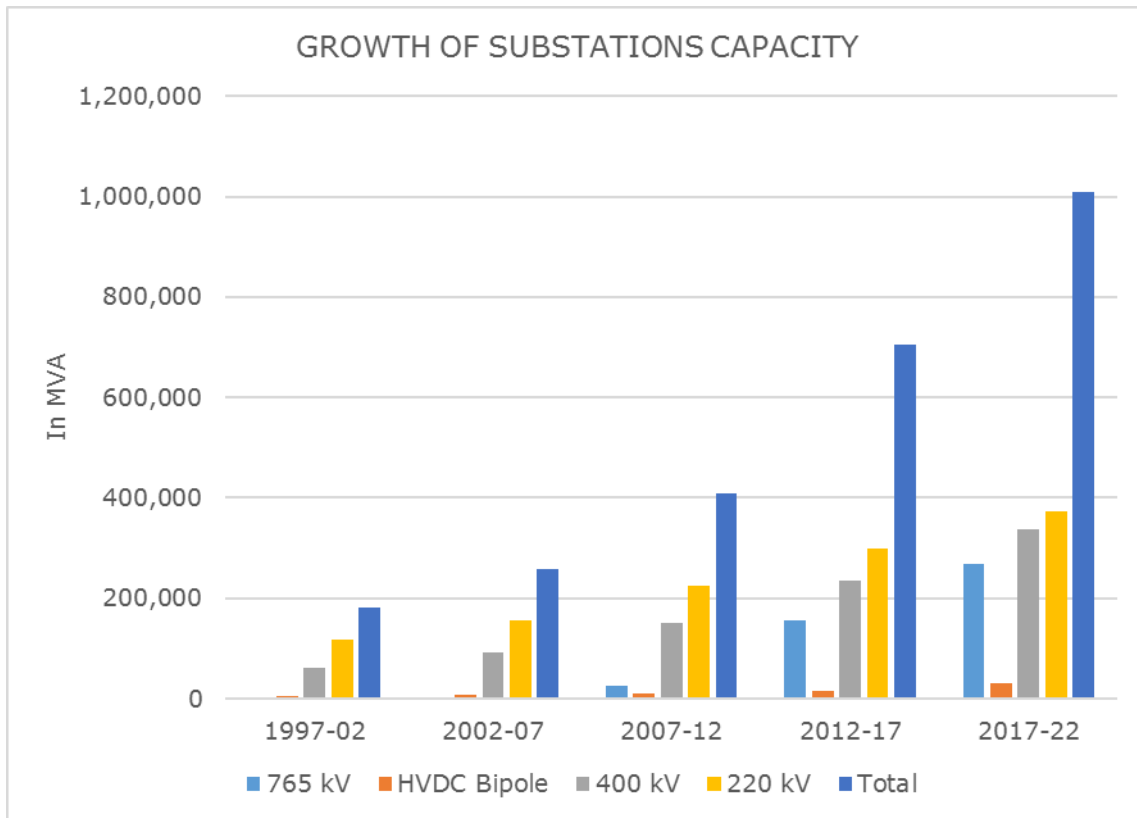

Figure 16: Growth of substation capacity (in MVA)

The progress of transmission system expansion has gained much momentum compared to previous planning periods and overall total transmission lines and transformation capacity added during 2012-17 period have achieved their targets. However, this does not ensure total power delivery from generation to load centres. The special distribution of the generation and load is very important and hence it should be considered together with adequacy of transmission system. A coordinated development of generation and transmission system is needed for delivery of power to various load centres at all time. CEA statistics show that the actual generation capacity addition during 2012-17 has been 48 GW short of the target (deviation of 55%). A total of 88 GW was planned to be added to the system to meet a demand of 198 GW forecasted for end of the plan period. The likely peak demand by the end of the plan is about 165 GW only. Out of the 88 GW of projected generation capacity addition, 21.3 GW has slipped for the plan period and new generation of about 35 GW is likely to be added by the end of the plan period which were not planned in the original capacity addition plan. Hence the total generation capacity addition by the end of the plan period is about 102 GW [3]. This indicates potential risks in generation, transmission, and distribution capacity additions.

Notwithstanding the challenges observed in the power sector, the renewable sector showed considerable development. Various policies, regulatory, and fiscal incentives in central and state level have stimulated the renewable energy sector. Recognising the importance of large-scale renewable integration, MNRE and FOR have entrusted PGCIL to carry out techno-commercial studies to identify the transmission infrastructure and control requirements for renewable capacity addition. This study resulted in a comprehensive report identifying the transmission corridor connecting renewable rich states, Tamil Nadu, Karnataka, Andhra Pradesh, Gujarat, Maharashtra, Rajasthan, and Himachal Pradesh. The CAPEX requirement for this project is estimated to be around €6.16 billion (INR 43,000 Crore). This project is labelled as the 'Green Energy Corridor (GEC) Project' and targeted to be completed by 2016-17 [22]. Once completed, this transmission corridor will reinforce the south-west-north transmission



infrastructure and thereby enhance power evacuation and balancing capabilities of the system and thereby enable higher capacity renewables like offshore wind farms to be integrated into the system. Figure 17 provides a map showing the high capacity transmission corridors envisaged under GEC project [22]. The importance of this project with respect to the proposed offshore wind integration in Tamil Nadu and Gujarat is discussed in the following sections.

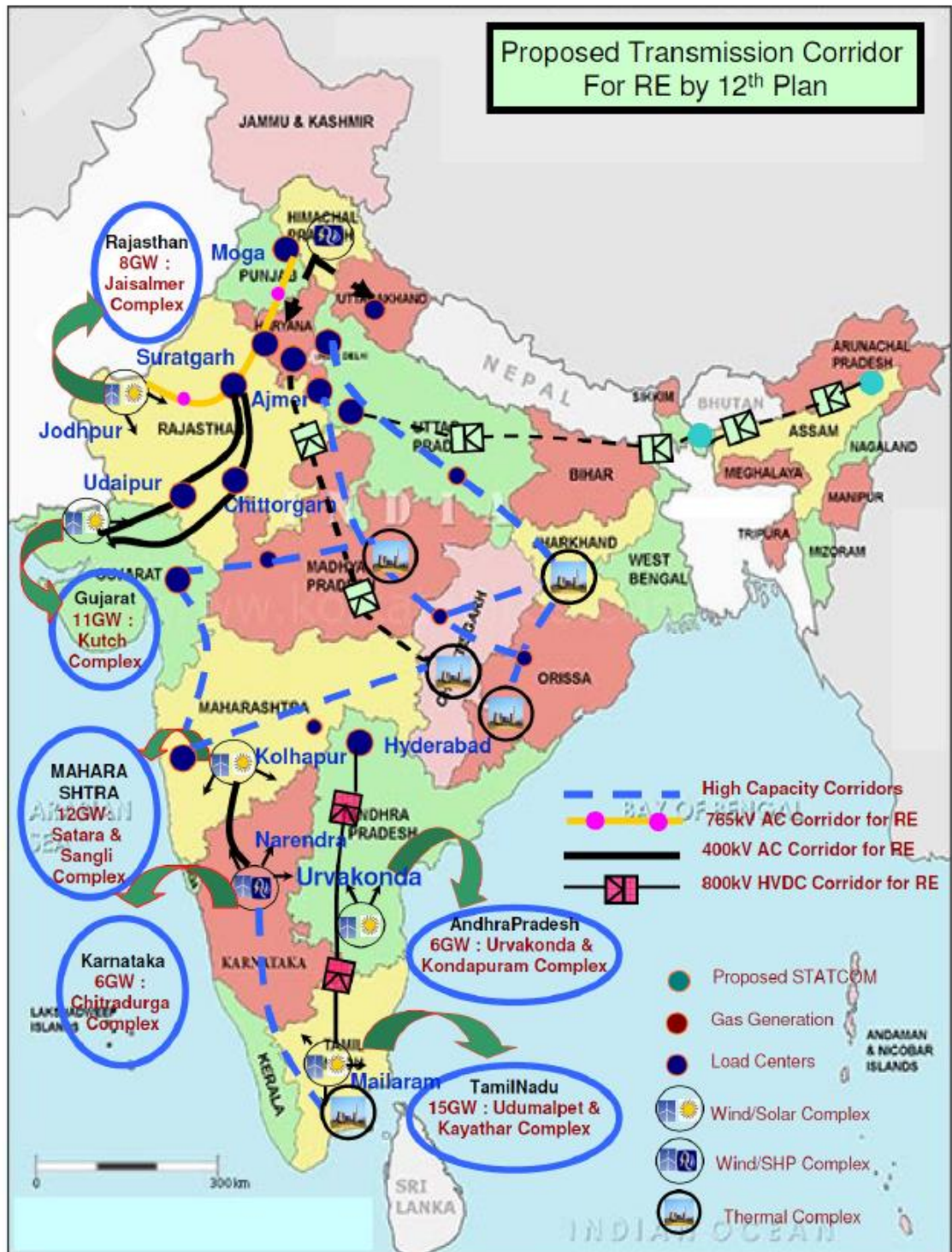

Figure 17: Proposed Green Energy Corridor for renewable evacuation



4.2 Overview of Gujarat Power System

4.2.1 Transmission System Infrastructure

Gujarat state has a reliable grid infrastructure with a wide spread intra-state network and is connected to the neighbouring states and other regions through the Intra-STS at 765 kV, 400 kV, HVDC, and 220 kV lines. Figure 18 shows the existing transmission network infrastructure of the state [23].

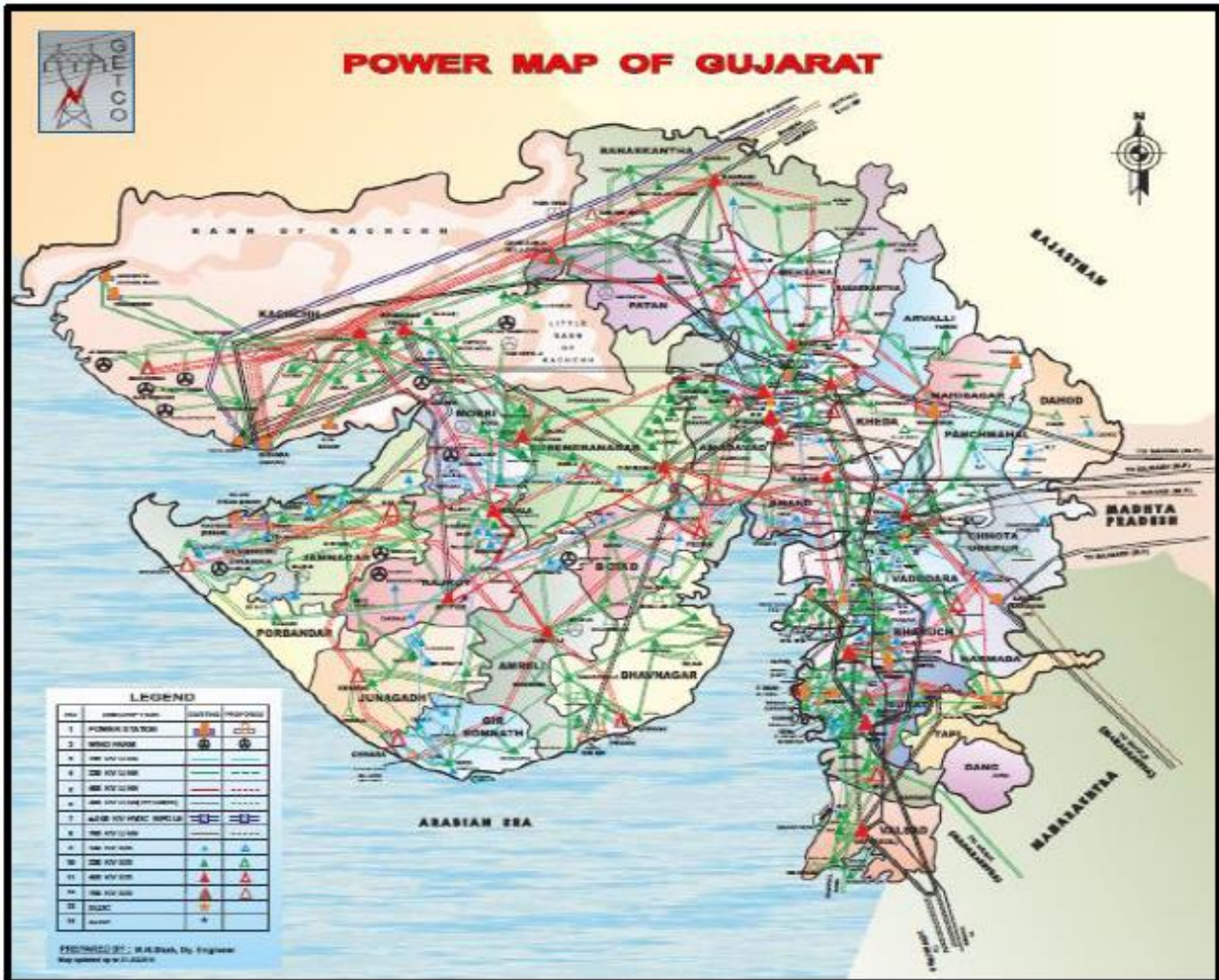

Figure 18: Intra-state transmission network, Gujarat

The onshore wind, offshore wind, and solar resources map for the state is given in Figure 19 [24], [25]. The wind generation capacity addition is primarily concentrated in districts of Kutch, Jamnagar, Rajkot, Surendranagar, Banaskantha, Patan, Morbi, Dwarka and Amreli, while solar generation capacity addition is primarily concentrated in the districts of Kutch, Banaskantha, Patan, and some parts in districts of Surendrangar, Junagadh, and Ahmedabad. The FOWIND pre-feasibility study report identified 8 zones (Zone A-H) with favourable locations for offshore wind generation, which are located near transmission zones of Junagadh, Amreli, Bhavnagar, Porbandar, Jamnagar, Surat, Valsad, Navsari, Surat, Bharuch, Vapi [25].

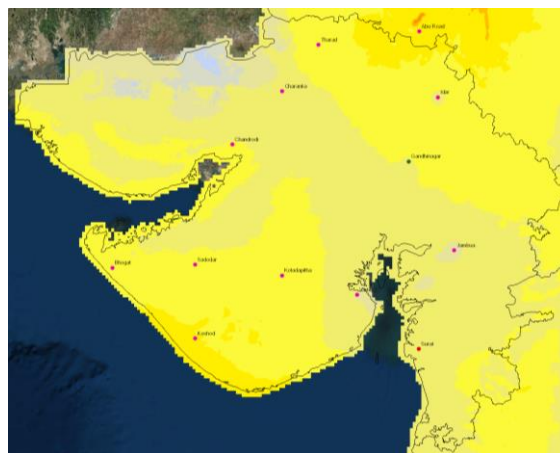
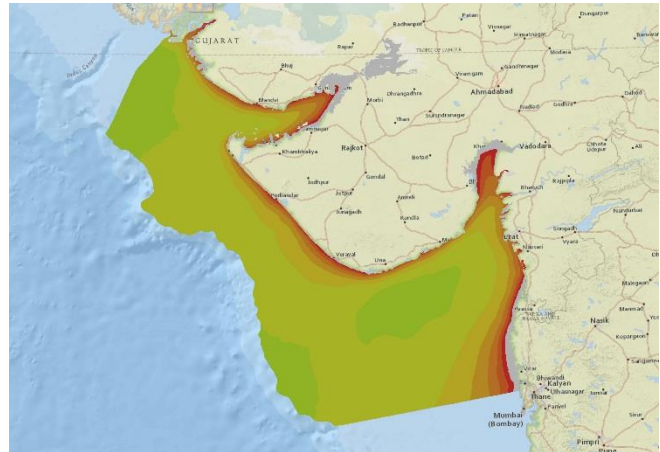
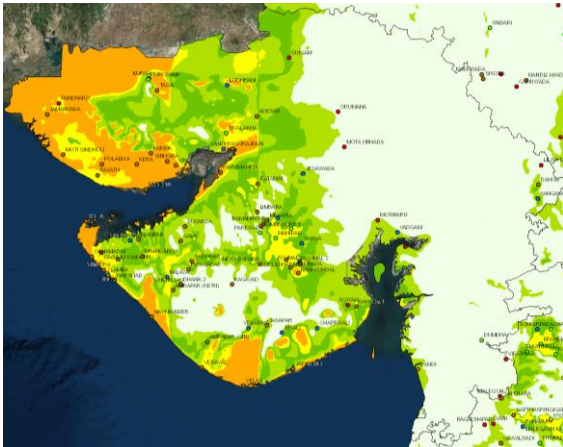

Figure 19: (Clockwise from top left) Onshore wind, offshore wind, and solar resources of Gujarat

Figure 18 illustrates the approximate geographical placement of current wind and solar generation capacities existing in the state. It is expected that the wind and solar rich regions will continue growing creating renewable pockets in western sides of the state (in Saurashtra and Kutch). Figure 20 shows the possible renewable power flow scenario together with offshore wind generation. Significant power flow is expected in the west-east transmission corridor wherein the demand centres on the eastern side of the states will be served by the renewables on the western side. The excess renewables shall be evacuated to other major load centres in the Northern regional grid via various inter-state corridors. The initial offshore wind generation regions can be connected to western and southern transmission corridors and to various inter-state transmission corridors connected to the southern parts of the state.

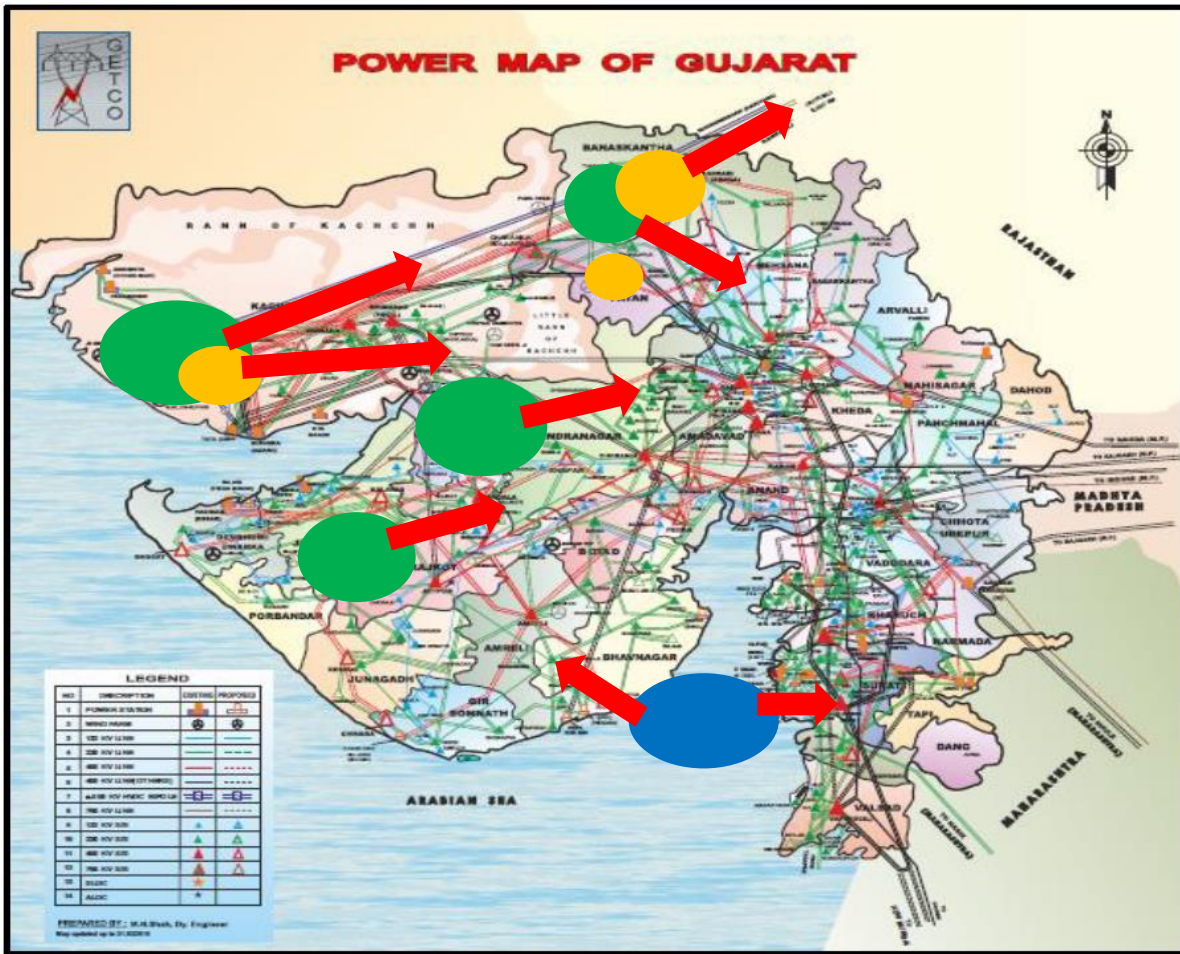

Figure 20: Renewable power flow scenario, Gujarat (Green: Onshore wind zone, Blue: Offshore wind zone, Yellow: Solar zone, Red: Power flow direction)

4.2.2 GETCO Case Study: Power Evacuation from a 500 MW Wind Farm

The Gujarat Electricity Grid Code specifies the following connectivity criteria pertaining to renewable plants:

- 50 MW capacity through 66 kV double circuit line of Aluminium Conductor Steel Reinforced (ACSR) Dog conductor. No contingency planning required.
- 70 MW capacity through 66 kV double circuit line of ACSR Panther conductor. No contingency planning required.
- More than 70 MW capacity through 132 kV/ 220 kV/ 400 kV (based on geographical location) double circuit lines. N-1 contingency criterion is preferable for more than 70 MW on these voltage classes.

Note that the terminology used are specific for onshore renewable plants connected to the transmission network via overhead lines. The offshore transmission grid uses submarine cables and hence ACSR conductors specified are not applicable.

Based on international experiences, an offshore wind farm with a capacity of 150 MW shall be suitably connected to a 220 kV onshore substation, while higher capacities such as 500 MW would require a 400



kV onshore substation. The highest AC connection voltage used in current submarine systems is 220 kV and this would need a step-up transformer to be connected to the 400 kV station.

The wind energy policy of Gujarat states that the power evacuation infrastructure for wind farms up to 100 km from the grid shall be installed by the project developer at their cost and beyond 100 km the power evacuation infrastructure shall be installed by the STU. These provisions are set out for onshore renewable plants in perspective and there exists different potential offshore grid ownership models employed internationally (see Section 5.5 for details). In order to understand the possibilities of offshore wind evacuation, various onshore substations in 132 kV/ 220 kV/ 400 kV levels in the vicinity of the shortlisted offshore wind zones are identified. The effective power evacuation will depend upon the existing load on the connecting substation, load-generation and power flows in the area, ability of the local system to accept the additional load, and extra short-circuit contribution levels from the offshore wind generation system.

Table 3 presents a list of existing 132 kV/ 220 kV/ 400 kV substations identified near zone A-H [25].

Offshore Zone	Nearest Transmission Zone	Name of the Substation	Voltage (kV)	Aerial Point-to-Point Distance (km)
A	Junagadh	Dhokadava	220	48
	Amreli	Ultratech	220	23
B	Amreli	Ultratech	220	26
		Otha	220	25
C	Junagadh	Talala	132	48
	Amreli	Dhokadava	220	28
		Ultratech	220	8
		Otha	220	47
		Ambuja	132	17
		Timbdi	220	28
D	Navsari	Ambheta	220	36
	Bharuch	Navsari	220	30
		Mora	220	21
		Vapi	220	35
		Vapi	400	40
		Bhilad	220	40
		Atul	132	23



Offshore Zone	Nearest Transmission Zone	Name of the Substation	Voltage (kV)	Aerial Point-to-Point Distance (km)
		Sachin	220	26
		Magarwada	220	26
E	Valsad	Vapi	220	59
	Surat	Magarwada	220	53
		Bhilad	220	54
F	Surat	Otha	220	33
	Bharuch	Sagapara	220	50
	Bhavnagar	Vartej	220	40
		Dahej	220	14
		Ankleshwar	132	48
		Kosamba	400	41
		Essar Steel	400	8
		Navasari	220	43
		Sachin	220	34
		Bhestan	132	31
G	Jamnagar	Bhatiya	132	25
		Ranavav	220	33
H	Jamnagar	Ranavav	220	32
		Keshod	220	40

Table 3: List of existing 132 kV/ 220 kV/ 400 kV substations identified near zone A-H

A detailed power system study will be required to assess the capability of the existing transmission network to accept the offshore wind power and to evacuate it from the area. This study would ascertain the requirements for network reinforcement and upgradation.

FOWIND collaborated with GETCO (the STU) to carry out system studies to evaluate the impacts of integrating different volumes of offshore wind power into the transmission network in different timeframes. The following study case is chosen:

- 500 MW by 2020

The initial project size of 500 MW was selected for 2020 so as to align with the 504 MW project size considered for FOWIND pre-feasibility reports. The study year is chosen to be 2020 only to understand



the readiness of the transmission infrastructure if a high volume of offshore wind power is realised in a very short time period.

A 500 MW offshore wind project near Pipavav Port, Bhavnagar (offshore wind farm located in Zone A) is considered under the 2020 timeframe. GETCO conducted load flow and short-circuit studies to check the feasibility and to assess the transmission infrastructure required for this project during peak and off-peak conditions in 2020. These studies are carried out in consideration of an equivalent 500 MW injection from an onshore pooling station near Pipavav to be established by the offshore wind developer. The evacuation of the offshore generated power to the onshore pooling station is considered as the responsibility of the project developer.

The load flow studies for both peak load and off-peak conditions are simulated together in selected contingency cases in both scenarios. The results are compared against the transmission planning criteria as well as the Gujarat Electricity Grid Code to check violations. The short-circuit study is conducted in a peak load scenario with fault levels at nearby substations. The study results are summarised in Table 4.

SI No	Scenario	Study Case	Remarks
1	Peak load	Load flow	Bus voltages within limits; Line flows less than thermal loading capacity
2	Peak load	Contingency analyses	Line flows and key component loading are within limits
3	Off-peak load	Load flow	Bus voltages within limits; Line flows less than thermal loading capacity
4	Off-peak load	Contingency analyses	Few line loading violations
5	Peak load	Short-circuit analysis	Fault levels within allowed short-circuit ratings

Table 4: Summary of study cases and results

The study results show that there are possible loading violations in contingency studies in off-peak load conditions. The system loading reduces substantially in off-peak loading conditions and the wind farm generation should be reduced to a level that any element of the intra-transmission network shall not become overloaded. The results further identify generation curtailment shall be necessary in other system loading scenarios where contingency cases will result in system loading violations. These conclusions indicate that system reinforcement will be necessary in intra-state and inter-state levels to evacuate the offshore wind power effectively at all operating conditions.

The complete study report is attached in the Appendix 1.

4.2.2.1 FOWIND's Observations

FOWIND has made the following interpretations of the system study assumptions and results:

- The study is purely based on steady-state power flow in peak and off-peak load conditions in network infrastructure planned in 2020 and ignores the operational issues like renewable variability, intermittency, unplanned outages in system etc. If the system is not prepared to handle these issues, it could result in offshore wind curtailment.
- The feasibility of offshore wind power transfer capability shall be further studied via a dynamic assessment focused on the local transmission grid with a specific focus on transient stability analysis and voltage stability analysis.



- In one of the N-1 contingency cases (Case 2 in study report), one of the lines loading reaches up to 145% of its rating. This specific loading is lesser than thermal loading limit of the line and hence considered as normal practise under GETCO operating philosophy. However, it is recommended to limit the loading up to the normal loading limits of different transmission components.
- The study is based upon the assumption that the generated power from the proposed offshore wind project will be consumed within Gujarat only. However, inter-state and inter-regional transmission lines exist and are being constructed for any excess power generation and hence this assumption may limit the feasibility of future offshore wind projects.

4.2.3 Grid Infrastructure Developments Relevant to Offshore Wind Generation

In view of the growing demand and large scale integration of renewables, the existing transmission system would need to be strengthened both at intra-state and inter-state level with proper planning. The 400 kV ring main system is being developed to improve the reliability of the transmission system. These developments should positively impact the growth of offshore wind sector in the state.

The intra-state grid development in the Saurashtra region and Southern Gujarat region are important as these systems could be the onshore grid intake points for the identified offshore wind project zones. Figure 21 shows the Intra-STS development plan for GETCO [26]. This plan shows that many of the transmission strengthening projects are going to impact the power evacuation routes for offshore wind farms in the Saurashtra region as well as to strengthen the transmission system near major load centres near the capital area.

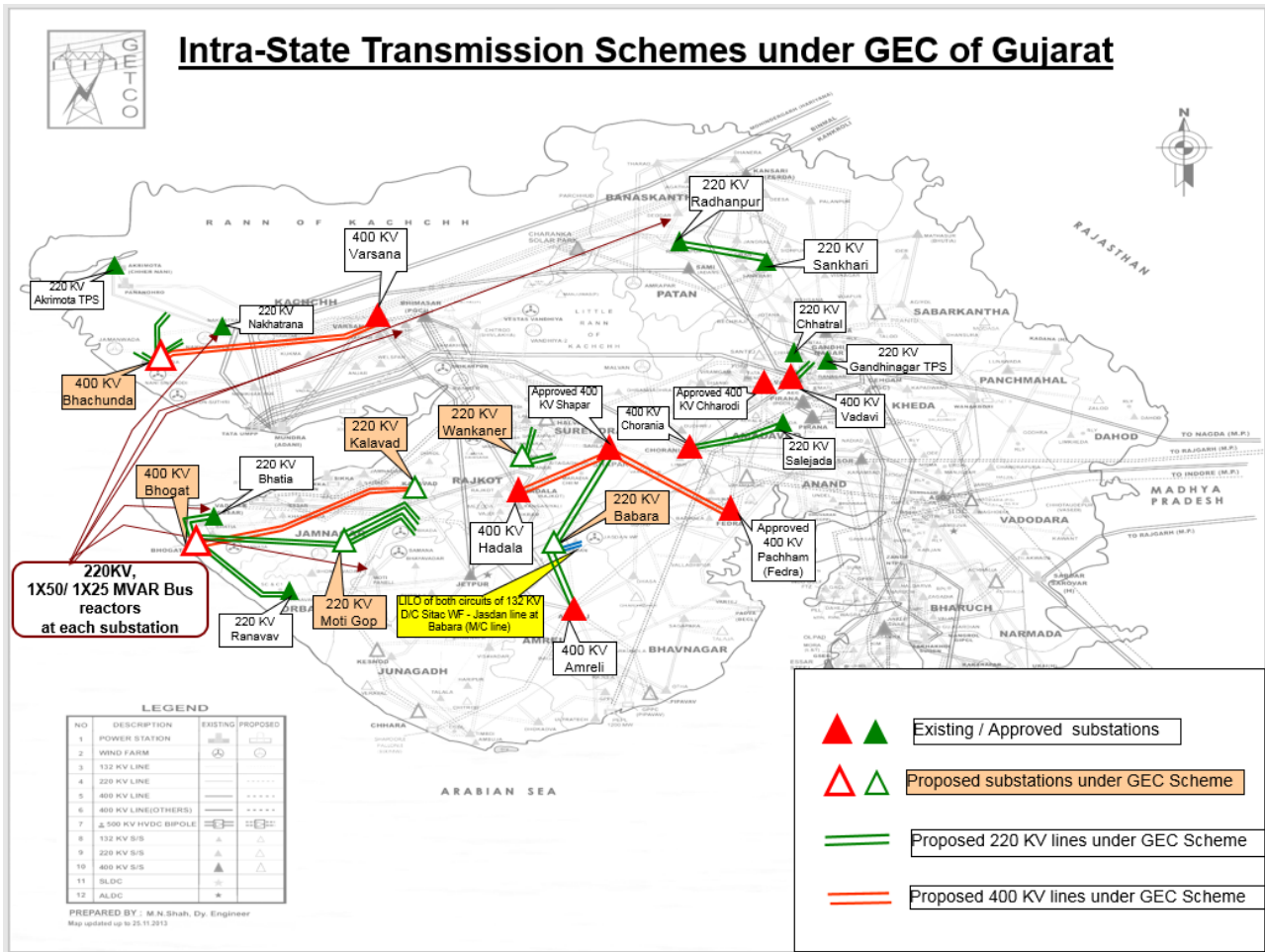

Figure 21: Intra-state transmission strengthening scheme, Gujarat

The inter-state grid strengthening plans proposed under the GEC project are also important in view of the evacuation of excess renewable power out of the state during low demand periods. The wind and solar power complex mainly in the Kutch area of the state (via 765/400 kV pooling station) is being connected to Moga in Punjab via Chittorgarh/Ajmer/Bikaner in Rajasthan (all located in the northern grid region). Figure 22 shows the schematic representation of this development under the GEC project. This specific project might not have direct implications on offshore wind developments, however it will help to manage various operational issues (as described in Section 6) and thereby facilitate larger scale renewable integration.

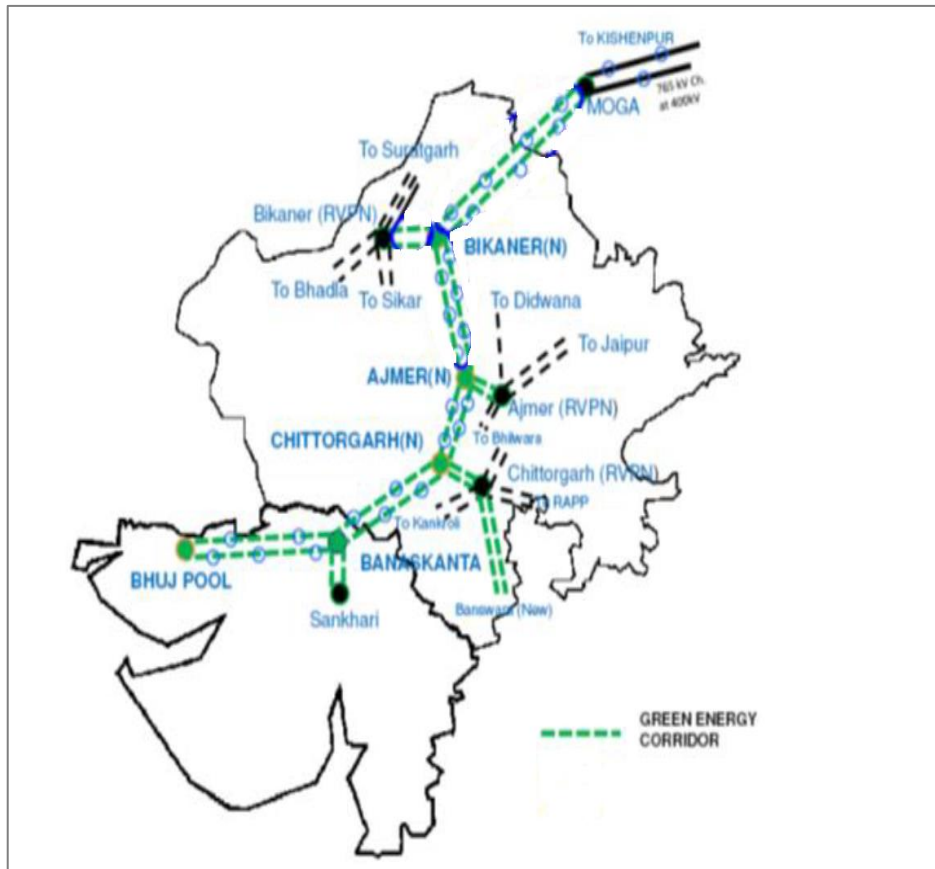

Figure 22: Green Energy Corridor scheme for evacuating renewable power from Gujarat

The offshore wind projects in the state should explore the possibility of evacuating power directly into the inter-state/ inter-regional transmission corridors planned under GEC schemes. Table 5 lists down major inter-state/ inter-region transmission development projects planned in Gujarat and their relevance in renewable integration across the country [22].

Southern Region (SR) -Western Region (WR)/ Eastern Region (ER)- Northern Region (NR) Transmission Corridors
<ul style="list-style-type: none"> ▪ 765kV Tamil Nadu (SR) RE complex- Maharashtra/Gujarat (WR)- Rajasthan-Haryana/Delhi (NR) D/c; ▪ +800kV, 6000 MW (Multi terminal) Tamil Nadu/Karnataka RE complex- Uttar Pradesh load centres HVDC Bipole; ▪ 765kV Karnataka (SR) RE complex- Maharashtra/Madhya Pradesh (WR)- Uttar; Pradesh/Uttaranchal- Punjab (NR) load centres D/c; ▪ +500kV 2500 MW Tamil Nadu - Andhra Pradesh HVDC Bipole and 765kV Andhra Pradesh (SR)- Maharashtra(WR) load centres; ▪ 765kV Tamil Nadu /AP (SR) RE complex – Orrisa (ER)– Jharkhand (ER)– Bihar(ER)– UP/Punjab (NR) Load centres D/c.
Western Region- Northern Region Transmission Corridor



- 765kV Gujarat RE complex – Rajasthan- Haryana/Delhi (NR) D/c;
- +800kV 6000 MW (Multi terminal) Gujarat - Rajasthan RE complex – Punjab load centres HVDC Bipole;
- 765kV Rajasthan RE complex (Jaisalmer/Barmer)– Central Rajasthan – Punjab- J&K load centres D/c.

Table 5: List of major inter-state and inter-region GEC projects passing through Gujarat

4.2.4 Key Issues for Offshore Wind in Gujarat

The key delivery risks for development and integration of offshore wind projects into Gujarat’s power system are given below:

- The right of way constraints and unavailability of lands are reported as the causes of many delayed transmission projects and this is a major concern for timely development of the offshore wind sector in the state. The offshore wind projects extend beyond the land boundaries and could potentially complicate the current challenges.
- Most of the renewable capacity in the state is located in the western part of the state, i.e. Kutch and Saurashtra. The main load centres are in eastern or south-eastern parts of the state. The existing connection capacity between western and eastern parts of the state is not fully adequate to evacuate future growth of renewable generation. The intra-state grid development needs to reinforce this section of the grid.
- The current grid infrastructure development is focused on onshore wind and solar generation which are mainly concentrated in the Kutch area and in Saurashtra around Gulf of Kutch. The offshore rich areas of Saurashtra do not have any major transmission system infrastructure planned at the present time. This will be a critical delivery risk in medium to long term. The intra-state and inter-state transmission planning need to consider the possibilities of large scale offshore wind capacity additions while preparing their prospective plans.
- To firm up plans for disposing surplus power on a short or medium term basis through bilateral arrangements, power exchanges and revenue earnings.
- The generation capacity addition in previous plans show some slippage, leading to installed capacity at the end of the plan period falling short of the target. Major reasons for such slippages are identified in the National Electricity Plan (Generation) and some issues which could be affect offshore wind power development are: problems in acquiring land, issues in timely completion of power evacuation systems, contractual issues, environmental issues, lack of affordable financing, delay in signing of long-term PPAs with Distribution Companies (DISCOMs) etc.
- Several 400 kV substations recorded over-voltage exceeding 420 kV in 2014-15 and 2015-16 [23] and some of these substations are closer to possible offshore wind project connection points. This indicates limited inductive reactive power compensation capability in the affected areas.
- Several 220 kV substations recorded under-voltages during seasons with high agriculture demand. Some of these substations are closer to possible offshore wind project connection points [23]. This indicates limited capacitive reactive compensation in the affected areas.



4.3 Overview of Tamil Nadu Power System

4.3.1 Transmission System Infrastructure

The state of Tamil Nadu has a reliable grid infrastructure with a wide spread intra-state network and it is connected to the neighbouring states and other regions through the Intra-STS at 765 kV, 400 kV, HVDC, and 230 kV lines. Figure 23 shows the existing transmission network infrastructure of the state [27].

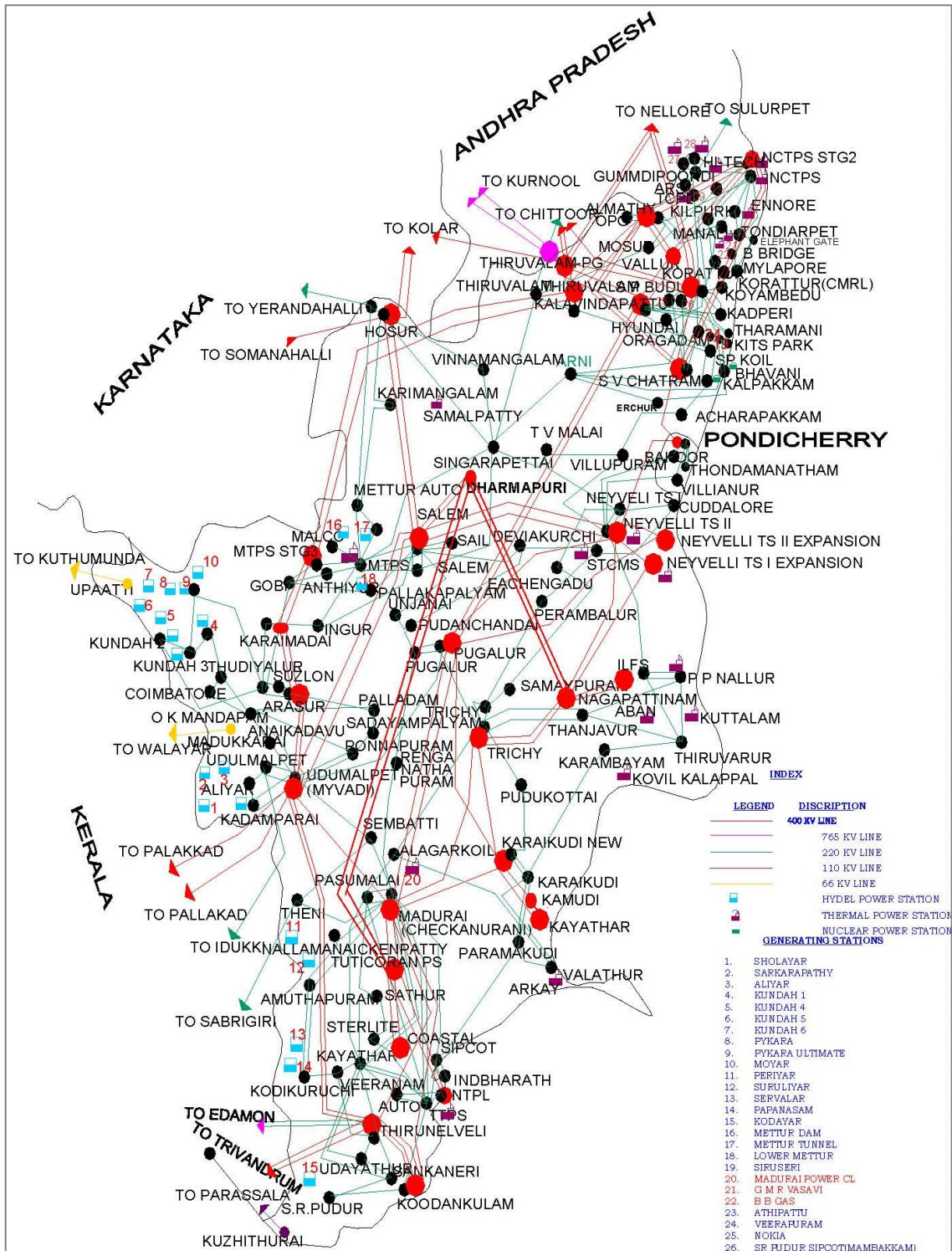

Figure 23: Intra-state transmission network of Tamil Nadu



The onshore wind, offshore wind, and solar resources map for the state is given in Figure 24 [24], [28].

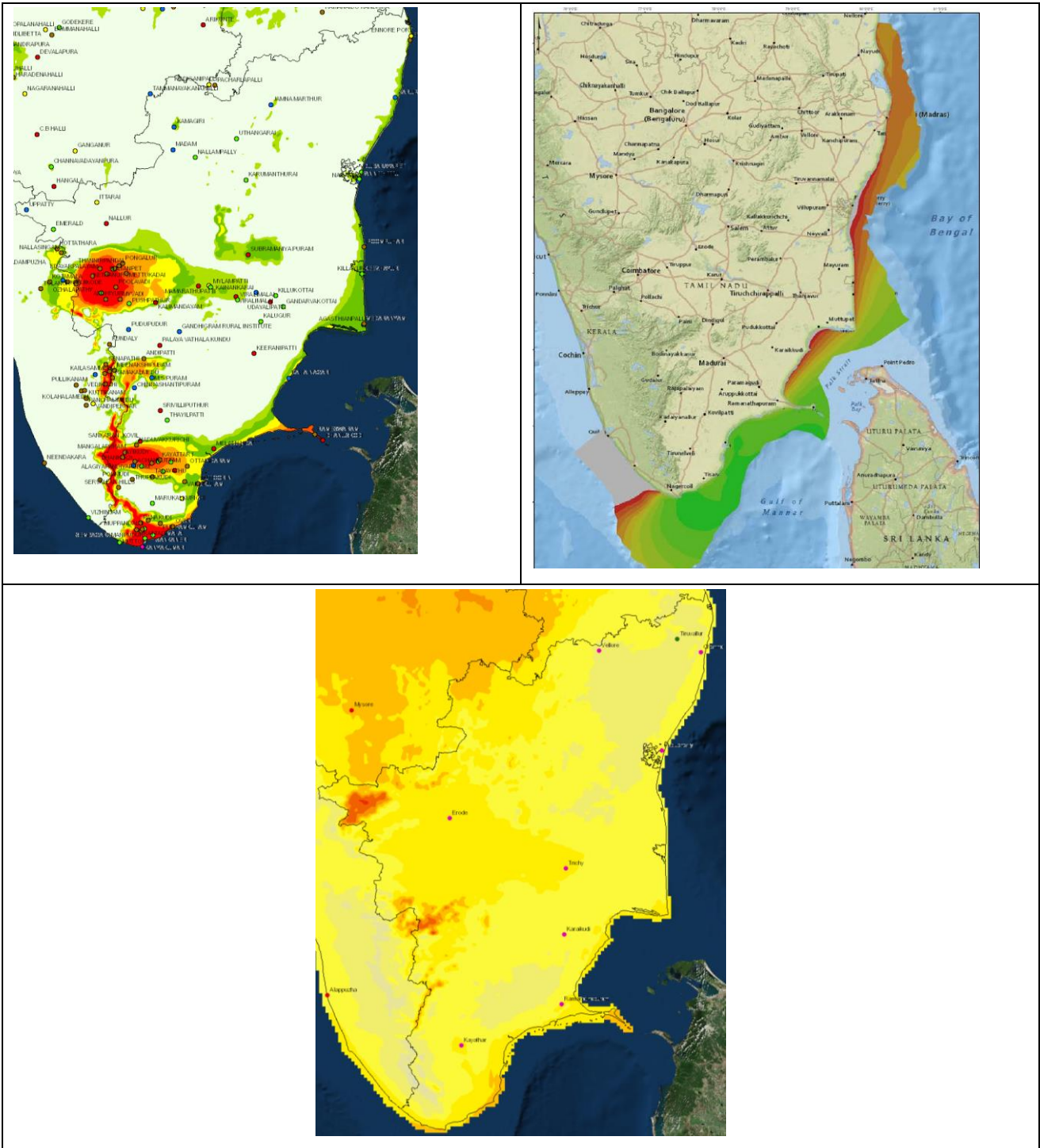

Figure 24: (Clockwise from top left) Onshore wind, offshore wind, and solar resources of Tamil Nadu

Most of the wind capacity additions in the state are envisaged in Kayathar, Udumalpet, Tirunelveli, Vagarai, Tennampatty, Thappagundu, Rasapaliyam, Anaikadavu, and Kanarpatty and it shows that significant wind potential is concentrated in Southern Tamil Nadu. These regions cover the majority share of the state’s existing wind capacity. The solar resources are spread across the state, with slightly higher potential towards northern parts. The FOWIND pre-feasibility study report identified 8 zones



(Zone A-H) with favourable locations for offshore wind generation, which are located near Manappad, Punnakayal, Tuticorin, Kanyakumari, Kudankulam, Rameshwaram, Valinokkam and Colachel [28]. These locations are very close to the transmission zones where the majority of onshore wind projects are located.

Figure 25 shows the possible renewable power flow scenario together with offshore wind generation. Most of the wind power (onshore and offshore) in the southern part of the state is expected to be pooled together in a dedicated renewable pooling station in the locality and mainly serves the load centres in northern parts of the state. The excess renewable capacity shall be evacuated to neighbouring states once the GEC transmission projects are commissioned.

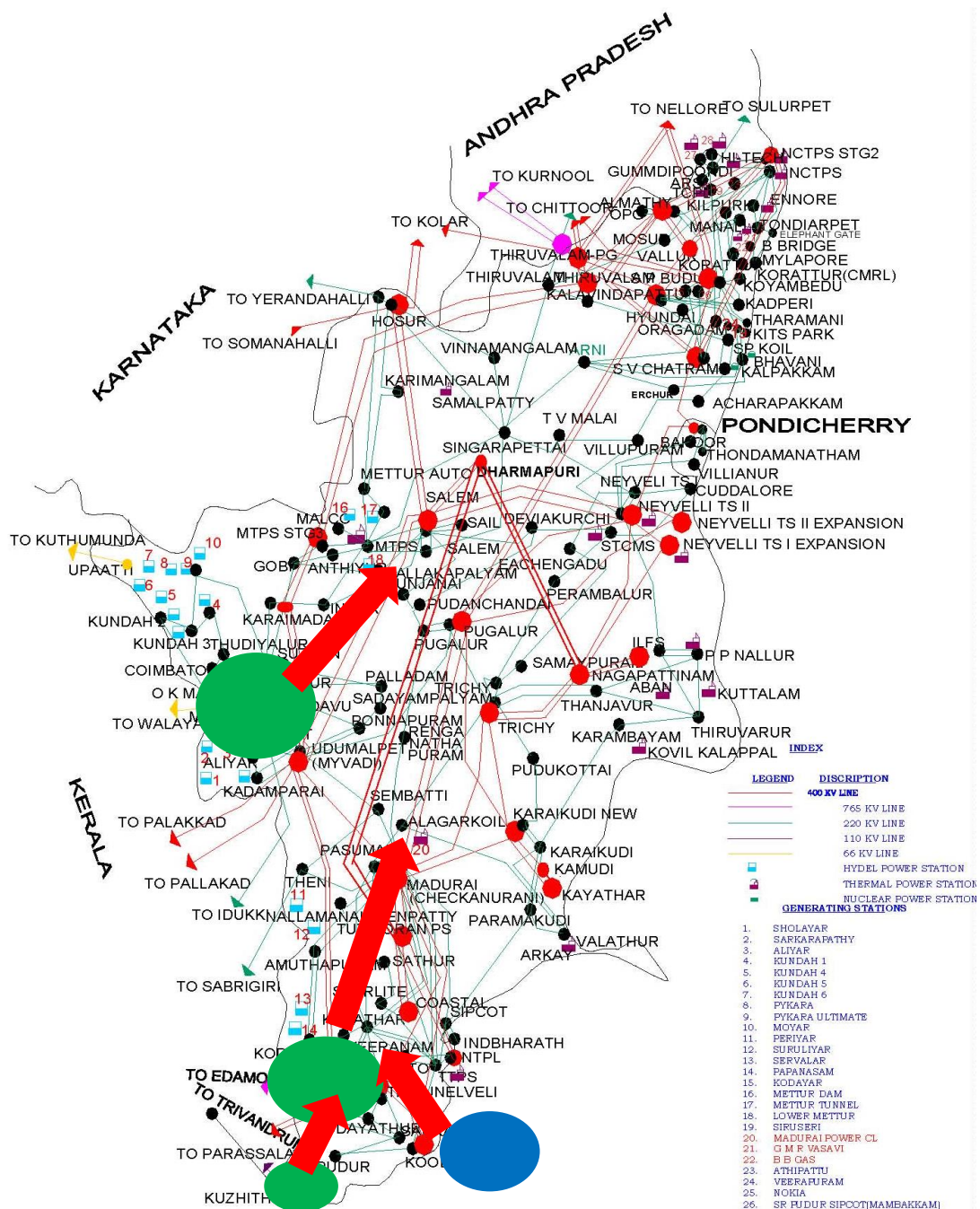

Figure 25: Renewable power flow scenario, Tamil Nadu (Green: Onshore wind zone, Blue: Offshore wind zone, Red: Power flow direction)



A detailed power system study will be required to assess the capability of the existing transmission network to accept the offshore wind power and to evacuate it from the area. This study would ascertain the requirements for network reinforcement and upgrading.

4.3.2 TANGEDCO Case Study: Power Evacuation from a 500 MW Wind Farm

FOWIND has requested TANGEDCO to carry out system studies to evaluate the impacts of integrating different volumes of offshore wind power into the transmission network in different timeframes. The following study case is chosen:

- 500 MW by 2021-22.

As mentioned in the case of Gujarat, the initial project size of 500 MW was selected for 2021-22 so as to align with the 504 MW project size considered for FOWIND pre-feasibility reports. The study year is chosen to be 2021-22 only to understand the readiness of the transmission infrastructure if a high volume of offshore wind power is realised in a very short time period.

According to Tamil Nadu Electricity Grid Code, generating stations shall be connected at levels of 400, 230, and 110 kV or as agreed by the STU. An offshore wind project of 500 MW is likely to be directly connected to a 400 kV station.

The 500 MW offshore wind capacity is considered near areas of Manapad, Punnakayal, and Tuticorin. TANGEDCO suggested connectivity at 400 kV at Samugarengapuram since it seems to be an approximately suitable location and this substation is planned to be commissioned by 2020-21. The network condition for the year 2019-20 is considered as the base case and five probable network development cases which could happen between the base case conditions and possible offshore wind project integration in 2021-22. Load flow analysis, 10 major contingency cases, and short-circuit analysis are simulated. The study results conclude that all transmission system component loading is normal and hence it is feasible to integrate a 500 MW offshore wind project in the 2021-22 scenario.

The complete study report is attached in Appendix 2.

4.3.2.1 FOWIND's Observations

FOWIND has following interpretations of the system study assumptions as well as the results:

- The study considers several network development cases in a timely fashion and impacts of delay or non-delivery of any of the sections could undermine the feasibility of offshore wind integration. Delayed development of transmission infrastructure is a major reason for grid curtailments in the state.
- Samugarengapuram substation is located very close to the major onshore wind pocket of Tamil Nadu. The total possible wind power injection at this station is estimated to be around 1200 MW. If any other onshore wind projects (with short gestation period) are approved for interconnection at this station before 2021-22, it could potentially limit the ability of the substation to accept a large scale offshore wind project.
- The study is purely based on steady-state power flow in peak and off-peak load conditions in network infrastructure planned for 2021-22 and ignores the operational issues like renewable variability, intermittency, unplanned outages in system etc. If the system is not prepared to handle these issues, it could result in offshore wind curtailment.



- The feasibility of offshore wind power transfer capability shall be further studied via a dynamic assessment focused on the local transmission grid with a specific focus on transient stability analysis and voltage stability analysis.

4.3.3 Grid Infrastructure Developments Relevant to Offshore Wind Generation

TANTRANSO is aggressively investing in development of the transmission sector in the state in order to ease the transmission congestion problems to evacuate wind power.

The transmission upgrade projects under GEC are of much importance for Tamil Nadu (shown in Figure 26). These projects are supposed to be developed in two phases: Phase I and Phase II. The Phase I is aimed at connecting the wind rich region of Kayathar to load centres in Chennai through a 400 kV transmission corridor and this project is nearing completion. The Phase II is strengthening the congested transmission corridors connecting the wind pockets in the Kayathar, Thenampatti, Anaikadavu regions to Salem 765/400 kV substation and thus provide a dedicated corridor to evacuate power out of the state. Phase I and Phase II are expected to provide 1.2 GW of power wheeling capacity for renewable power generation.



Scheme	Proposed Grid Infrastructure Development
Phase I (GEC)	Network consisting of 2 new 400 kV substations and 1,488 circuit kms of 400 kV lines, which will connect Kayathar- Karaikudi- Pugalur- Kalaivanthapattu- Sholnganallur for connecting the wind rich zones to the load centres in Chennai.
Phase II (GEC)	Separate corridor with the 400 kV substations at Thappagundu, Anaikadavu, and Rasipalayam and associated 400 kV lines to 765/ 400 kV substation being built in Salem.
Inter-state	New 400 kV substation in Tiruvalam along with associated transmission lines from Tiruvalam to Mettur Thermal power station- Stage III and 400 kV substation at Alamathy
JICA Assistance	Establish five 400 kV substations and 14 230 kV substations and associated transmission lines
Inter-Regional (GEC)	SR-WR/ER- NR Transmission Corridors <ul style="list-style-type: none"> ▪ 765kV Tamil Nadu (SR) RE complex- Maharashtra/Gujarat (WR)- Rajasthan-Haryana/Delhi (NR) D/c ▪ +800kV, 6000 MW (Multi terminal) Tamil Nadu/Karnataka RE complex- Uttar Pradesh load centers HVDC Bipole ▪ ±500kV 2500 MW Tamil Nadu - Andhra Pradesh HVDC Bipole and 765kV Andhra Pradesh (SR)- Maharashtra(WR) load centers ▪ 765kV Tamil Nadu /AP (SR) RE complex – Orrisa (ER)– Jharkhand (ER)– Bihar (ER)– UP/Punjab (NR) Load centers D/c

Table 6: List of major inter-state and inter-region GEC projects passing through Tamil Nadu

4.3.4 Key Issues for Offshore Wind in Tamil Nadu

The key delivery risks for development and integration of offshore wind projects to Tamil Nadu's power system are given below:

- The two southern districts of Tuticorin and Tirunelveli consist of almost 4 GW of existing onshore wind generation. Most of these wind power plants are pooled together in Kayathar and Madurai (Checkanoorani) and these substations are bottlenecks for further large scale capacity addition of renewables. Major load centres are located in the north and a sufficient high voltage transmission corridor is not available between the southern wind pocket and north. The timely development of a north-south power corridor under GEC scheme is anticipated. The offshore wind plant to be connected in this region will face similar challenges.
- Local power flow bottlenecks are common in Kayathar and Madurai, mainly because these substations are congested with renewable energy and not fully able to serve loads. This points to a case where sufficient receiving/pooling substations may not be available for the proposed offshore wind plants which will be developed in this region.
- The right of way issues are reported as one of the major challenges for transmission sector development. Lack of sufficient funding is another issue. These two factors could be serious delivery risks for offshore wind sector development in the state.



- Tamil Nadu has already met Renewable Purchase Obligations (RPO) and has surplus renewable power which can be evacuated to other states which are power deficient or short in complying with their RPOs. However, insufficient inter-state transmission corridors and lack of compliance to RPO target has led to low exports of renewable energy out of the state.

4.4 Recommendations

Key recommendations drawn from this chapter are summarised below:

Objective: Prepare the onshore grid for the integration of offshore wind		
Barrier	Mitigation	Key Stakeholder
Offshore wind not included in current grid planning scenarios	Formulate state and national targets for offshore wind Include offshore wind development scenarios in long term planning	MNRE, MoP CEA, CTU and STUs
Delayed delivery of necessary onshore grid reinforcements causing power export constraints	Prioritise anticipatory investment in grid expansion (eg. Green Energy Corridors)	CTU and STUs
Difficulty in obtaining right of way for onshore transmission infrastructure	Streamline national and state planning and permitting processes for critical infrastructure projects	MoP, SEB, CTU and STUs

Table 7: Key recommendations for onshore grid development



5 OFFSHORE GRID DEVELOPMENT

This section examines the offshore power system, and its key components, their characteristics and potential configurations. It will consider all components of the offshore power system, from the wind turbine terminals to the interface with the onshore power system. Firstly, the design process and typical offshore transmission components will be discussed, before moving on to a discussion of connection topologies and lastly a discussion of potential offshore grid connection delivery and ownership models.

5.1 Key design Considerations for Offshore Grids

In the planning and design of offshore networks it is necessary to take account of the following general design factors:

- **Technical Limitations of Assets:** e.g. continuous current rating (in the case of offshore cables, this is installation dependent), voltage operating range, fault levels etc.
- **Compliance:** With local codes, standards and regulations.
- **Capital Cost:** Of the offshore transmission system; which is correspondingly in absolute and relative terms than equivalent onshore RES projects (typically accounting for approximately +/- 20% of total CAPEX).
- **Electrical Losses:** Typically in the range 2-5% depending upon the export voltage and distance offshore. Valuation depends upon location of the metering and the allocation of transmission losses to different parties.
- **System redundancy and Resilience:** Due to the elevated capital costs, offshore transmission systems are generally not designed fully (n-1) redundant, therefore the risk exposure to single points-of-failure (e.g. submarine transmission cables) must be carefully considered and mitigated in design and specification.

Due to the large number of variables in offshore grid design, it is typical that a techno-economic optimisation process is undertaken based upon the above factors to ensure that the preferred connection design is taken forward. Typically power system studies would be undertaken in order to validate the selected concept design. This process is illustrated graphically in Figure 27 [25].

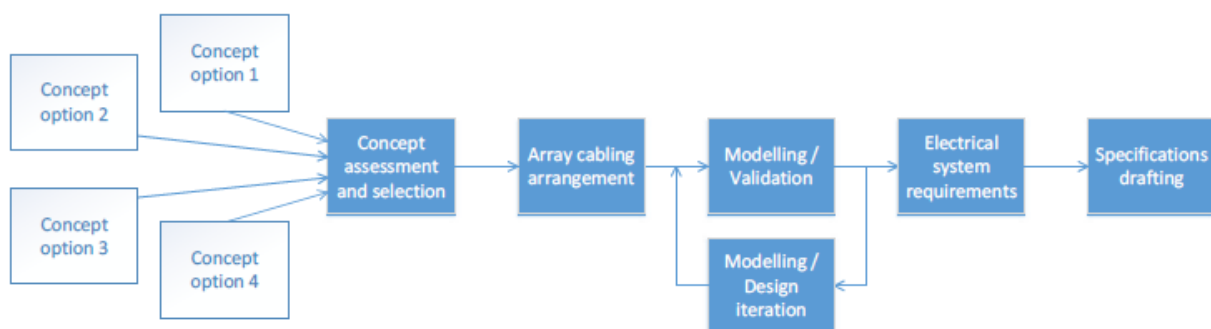

Figure 27: Typical Electrical Concept Design Development Process

The main project-specific factors which may drive the selection of the optimum system design are as follows:

- The scale of the project in terms of the maximum power to be exported, which along with distance from shore, is the primary driver to inform the decision on whether an offshore substation is necessary;



- Location of the project, in particular its distance from shore, and location of the onshore grid connection point;
- Electrical characteristics of the onshore grid connection point;
- The submarine cable route and preferred submarine cable installation methodology; and
- The potential site of the onshore/ offshore cabling interface.

Significant lessons have been learnt in mature offshore transmission industries when designing offshore electrical systems and application of appropriate technological and design solutions. It will be important for the Indian industry to learn from these mature markets and develop local capabilities in offshore grid system planning, design and implementation.

5.2 Offshore Grid Technology

5.2.1 Components of the Offshore Grid

Whilst offshore grid systems are very similar to traditional onshore grid systems, subtle differences in the nature of components and their ratings and application mean it is necessary to become familiar with the base components prior to discussing network topologies.

5.2.1.1 Offshore Wind Turbines

The electrical rating and performance of the offshore wind turbines can have a significant impact upon the offshore grid design. Offshore wind turbines are now available in sizes up to 8MW (with 9MW versions undergoing final qualification [29]); the growth of which has been driving new capacity requirements in offshore electrical systems (particularly array cables, see below). Offshore wind turbines generally produce electrical power at 33kV (on the high voltage side of the turbine transformer) but new variants including a 66kV transformer are entering the market in line with development of 66kV array cables (see below).

In terms of their performance, all currently available offshore wind turbines are of the Type 3 or Type 4 design (Doubly Fed Induction Generator and Full Converter respectively) which refers to the electrical generator and power converter configuration [30]. Such designs utilise power electronics and are capable of meeting modern grid code requirements for fault ride through and voltage control, helping to contribute to grid stability. The vast majority of offshore wind turbines available today are of the most flexible full-converter (type 4) design.

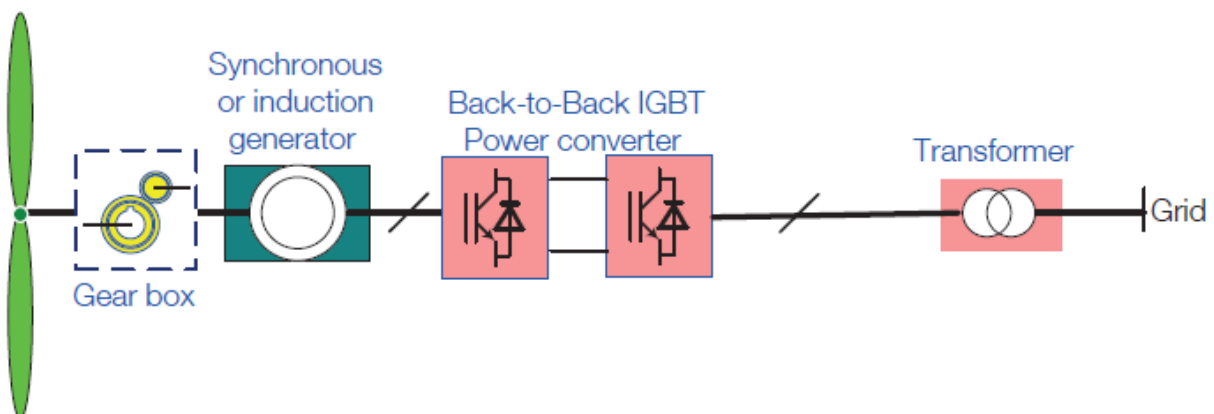

Figure 28: Electrical schematic of a full converter (Type 4) wind turbine (Source, DNVGL)



5.2.1.2 Offshore Array Cables

Array cables typically operate at medium voltage levels (usually 33kV) and are used to interconnect 'arrays' of offshore wind turbines together to transmit power to shore, or to an offshore substation.

Array cables are of a 3-core design (incorporating 3 phases into a single cable) using extruded insulation of XLPE (cross-linked polyethylene) or Ethylene Propylene Rubber (EPR) and are of a wet or semi-wet type, meaning that they do not employ an extruded, water blocking metallic sheath over the cable rendering them lighter and cheaper than offshore HV cables. Dimensions are often given as cross sectional area (CSA) of the conductor with 630mm² generally considered the maximum practicable size for handling in an offshore wind farm and connection to 33kV wind turbine switchgear. In such a case, the maximum power which can be carried on a single array cable is between 35-40MW. It is common practice to modify the CSA of array cables along strings, reducing the CSA nearing the end where less turbines are connected.

As the size of offshore wind turbines grow there has been a growing need for higher capacity array cables; where 9-10 3.6MW turbines may connect to a single 33kV cable, only 4, 8MW turbines may. This leads to less efficient cable layouts and has driven interest in higher voltage array systems, with the additional benefit that increasing the voltage also reduces electrical losses in the arrays. An industry consensus has developed around 66kV array voltages and it is expected that the coming years will see the first 66kV offshore array cables deployed.

5.2.1.3 Offshore High Voltage Alternating Current (HVAC) Substations

The fundamental purpose of offshore HVAC substations is to transform the medium voltage used in arrays to a higher voltage for more efficient transmission to shore. As well as MV/HV transformers offshore substations contain:

- HV Switchgear
- MV Switchgear
- Auxiliary and backup power systems
- Protection, control and communication equipment
- Reactive power compensation; optional, depending upon system design (shunt reactors, to compensate the capacitance of HVAC cables)

Offshore substations are large offshore structures consisting of a foundation (supporting sub-structure) and topside (housing equipment) and alongside HV submarine cables, are one of the most significant capital cost items in offshore transmission systems.

Offshore HVAC substations have been installed in sizes up to approximately 500MW and this is generally considered the practical economic limit due to size and weight restrictions on installation as well as the number of array cables which must connect to them (noting that the use of higher rated 66kV arrays may facilitate the economic construction of larger offshore HVAC substations by virtue of reducing cable congestion around the structure).



Figure 29: An example of an offshore HVAC Substation [31]

5.2.1.4 Offshore High Voltage Direct Current (HVDC) Converter Stations

Where HVDC transmission is to be used (refer to section 5.2.1.3 for further details on HVDC transmission) it is necessary to rectify the power from HVAC to HVDC for transmission to shore. This rectification process occurs at an offshore converter station. Such systems are considerably larger and more complex than HVAC offshore substations and correspondingly, considerably more expensive and the largest of them may only be fabricated in the larger shipyards in the world. Their supply is limited to a small group of large manufacturers who each use their proprietary systems and technology; therefore, interconnection of different systems is not currently possible.

Offshore HVDC systems are restricted to using the newer, voltage source converter (VSC) technology as older current source converter (CSC) technology cannot function correctly when connecting to offshore (electrical island) networks. Voltage and current ratings of VSC systems are lower relative to their CSC counterparts.

Offshore HVDC converter stations are presently employed with ratings of up to 800-900MW with 1000MW representing a practical maximum for the time being for a single system. Commonly they operate at +/- 200kV and above; with recent designs tending to coalesce around +/- 300-320kV DC.



Figure 30: Borwin Alpha (400MW) and Borwin Beta (800MW) installed side-by-side [31]

5.2.1.5 Submarine Export Cables

HVAC export cables connect the offshore HVAC substation either to shore, or to an offshore HVDC converter platform. Submarine HVAC cables are of a 3 core design (3 phases within a single cable) using extruded XLPE insulation. HVAC, 3 core submarine cables are presently used up to 220kV and are capable of transporting 300-400MW on a single cable circuit using practical cable cross-sections up to 1600mm² (aluminium) and 1200mm² (copper) to date.

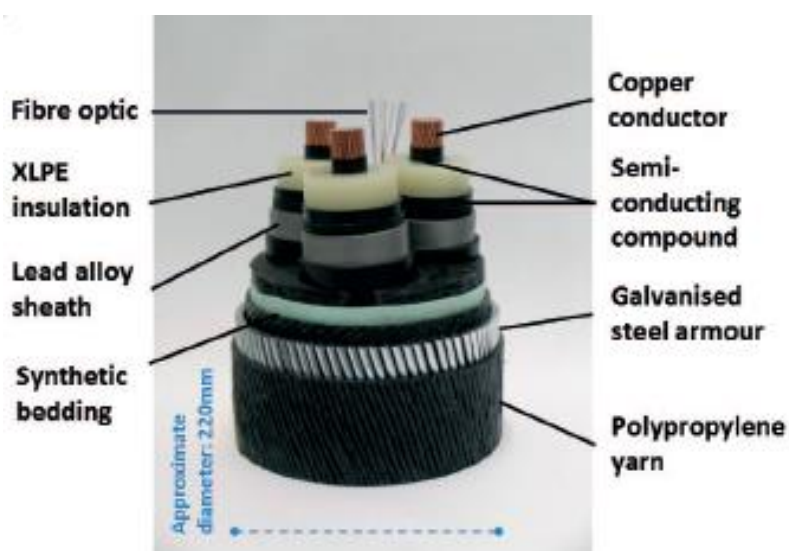

Figure 31: An example 220kV submarine HV Cable [31]

HVDC cables for VSC applications also typically utilise an extruded insulation and are available up to 400kV and consist of 2 single core cables of positive and negative polarity. They are normally installed in the same submarine trench, and their voltage must be matched to that of the offshore HVDC converter station. As such they are generally considered as a HVDC system, rather than separate elements, and therefore maximum ratings are of the order 800-1000MW per circuit.

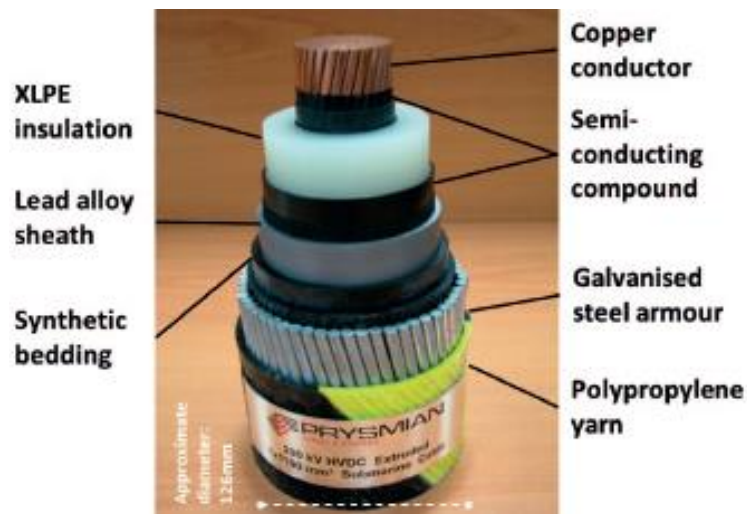

Figure 32: An example submarine HVDC cable [31]

The principle determinant of the power rating is the thermal rating (i.e. internal heat generated by the cable and its ability to dissipate this into the surroundings). Due to the high thermal mass of the seabed it can be possible, considering the variable nature of wind generation, to temporarily overload submarine cables without overheating them to achieve the upper end of this range of ratings; although such a design requires careful consideration of the time series of cable loads.

Submarine cables may utilise either copper or aluminium conductors; although copper is more common. Offshore cables are buried 1-3m in the seabed to protect them from damage during operation (submarine cable failures are the principle cause of outage time in offshore transmission systems) and careful assessment of the appropriate burial depth is crucial to mitigate in service failures. Submarine HV cables are generally installed from large dedicated cable laying vessels with the largest capable of carrying 50-100km of cable in a single load.

5.2.1.6 Landfall & Onshore Cables

When reaching landfall submarine cables are jointed to an onshore cable design at the transition joint bay. The landfall is a complex marine coordination operation requiring pull-in of cables from the installation vessel to the onshore transition joint bay. The landfall will often represent the thermally limiting case for the cable system as the burial can be quite deep. It is possible to splice a larger diameter cable to the landfall end of the submarine cable in order to mitigate this thermal constraint.



Figure 33: Cable barge and plough making landfall [31]



The onshore cable is typically a single core cable and may utilise a different conductor material (e.g. aluminium instead of copper) and requires less water blocking measures than submarine cable designs. Cross bonding is typically employed to minimise circulating currents in the cable sheath and increase equivalent rating (this is not possible for subsea sections). Onshore cables are installed in trenches (often in ducts) and buried as protection. The length of onshore cabling required will depend upon the proximity of the onshore substation to the landfall point.

5.2.1.7 Onshore HVDC Converter Stations

Onshore HVDC converter stations perform the inverse function to their offshore counterparts; inverting the HVDC power to HVAC and transforming it to the correct voltage for injection into the onshore grid. Once again these are large structures, containing complex electrical equipment and control gear and the exact design is unique to each manufacturer. Due to the specific capabilities of VSC HVDC no further power factor correction equipment is required; although some harmonic filtering is usually necessary due to the power electronic switches used in conversion from HVDC to HVAC and this will form part of the integrated design by the HVDC system manufacturer.

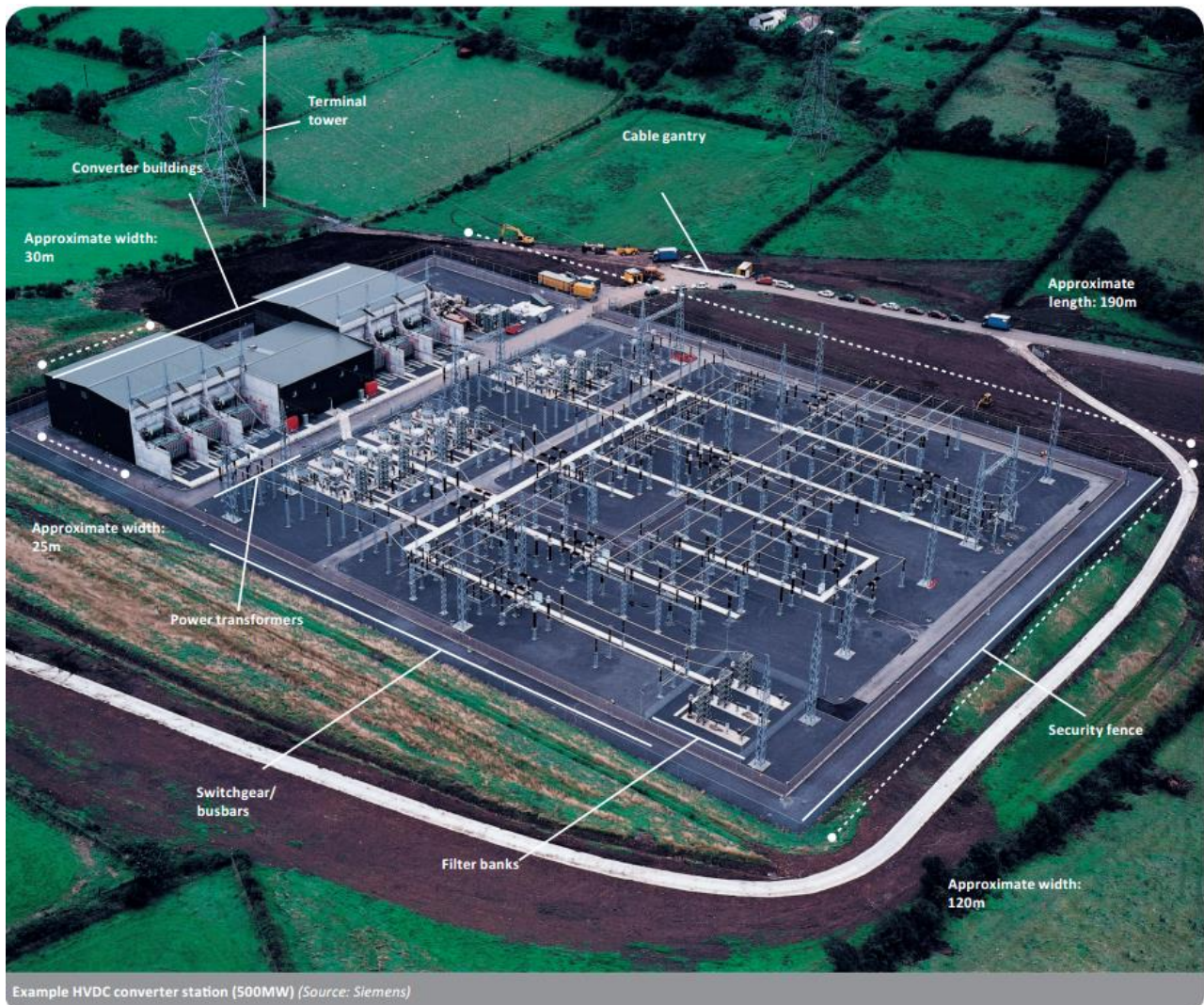

Figure 34: An example onshore HVDC converter station [31]



5.2.1.8 Onshore HVAC Substations

At the onshore HVAC substation the power received from the offshore power system is transformed to the correct voltage for injection into the grid. As well as HV transformers, the onshore substation will usually include:

- Fixed shunt reactors for compensating the HV cable
- HV Switchgear
- Protection, control and communication equipment
- Additional compensation devices for meeting the grid code (e.g. STATCOMS) may be required, depending upon system design and grid code requirements.
- Harmonic filters will normally, though not always, be necessary depending upon grid code requirements and local grid characteristics.

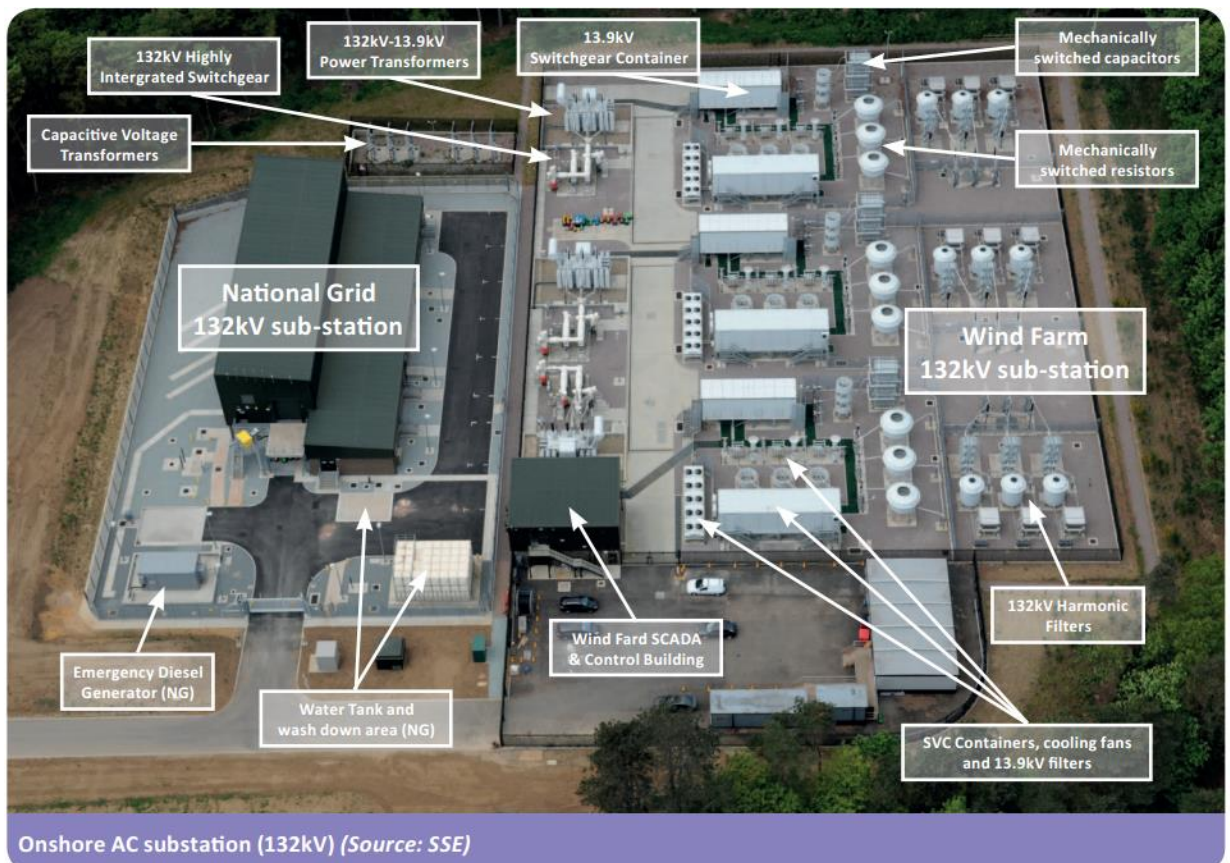

Figure 35: An example onshore HVAC substation [31]

5.2.2 Connection Type

In this section the principle connection types for offshore wind farms, as they have been employed in other markets, are presented alongside the advantages and limitations of each. The FOWIND Pre-Feasibility Studies identified several potential connection points for offshore wind farms in Gujarat and Tamil Nadu in proximity to the identified zones. The linear distance between the zones and their connection point ranges between 8-59km in Gujarat [25] and this will strongly influence the preferred design of the offshore transmission system. Given the typical MW size (>100MW) of offshore wind projects it is expected that connection to the state transmission system will be sought at 110kV or 132kV



or above. Larger projects (500MW+) or numerous aggregated projects may benefit from seeking connection to the EHV and UHV ISTS.

5.2.2.1 Medium Voltage AC

One possible connection design which removes the need for an offshore high voltage substation is a direct connection of turbines via extended medium voltage array cables. Given the very high capital costs of offshore substations this approach can lead to cost benefits over the other solutions described herein.

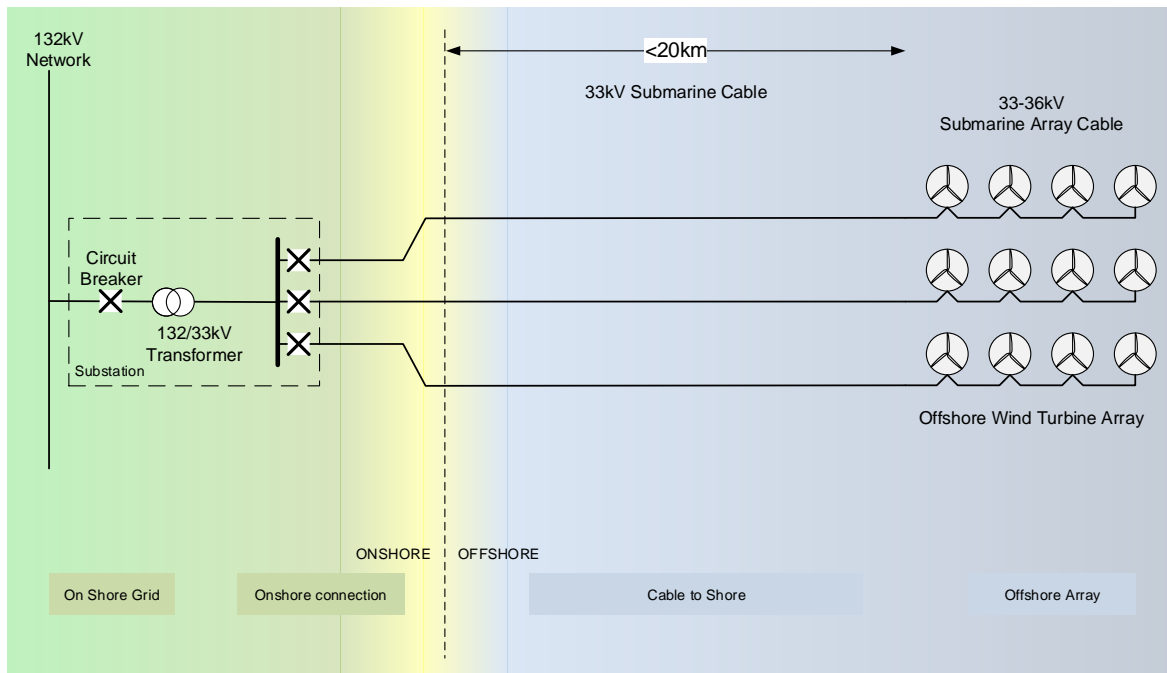

Figure 36: Illustrative MVAC connection (Source, DNV GL)

The power transfer limitations of medium voltage cables (circa 40MVA, maximum) mean that numerous cables are required to transmit the peak power from larger projects to shore leading to very high cable costs for more distant projects. Furthermore, the lower voltages that such connections operate at mean that electrical losses are proportionally higher which can have a significant impact upon an offshore wind farm's profitability for more distant connections.

As a consequence, this connection design is most suited to smaller projects (<90MW) [32] closer to shore (typically <20km; noting that the use of 66kV arrays may push this economic limit further).

Advantages	Disadvantages
Saves investment in an offshore substation	Numerous cables required for a given MW output (high cost, large rights of way)
Simple; minimises marine installation operations and offshore commissioning.	High electrical losses.
Reduced impact of single cable failure.	Typically limited to near-shore projects only.

Table 8: Advantages and Disadvantages of MVAC connections



5.2.2.2 High Voltage AC

The most common connection design for offshore wind projects to date utilises high voltage AC cabling to transmit larger volumes of power to shore. To enable the use of fewer, higher voltage cables it is necessary to install an offshore substation to transform the power from MVAC (as generated by the wind turbines) to HVAC for export.

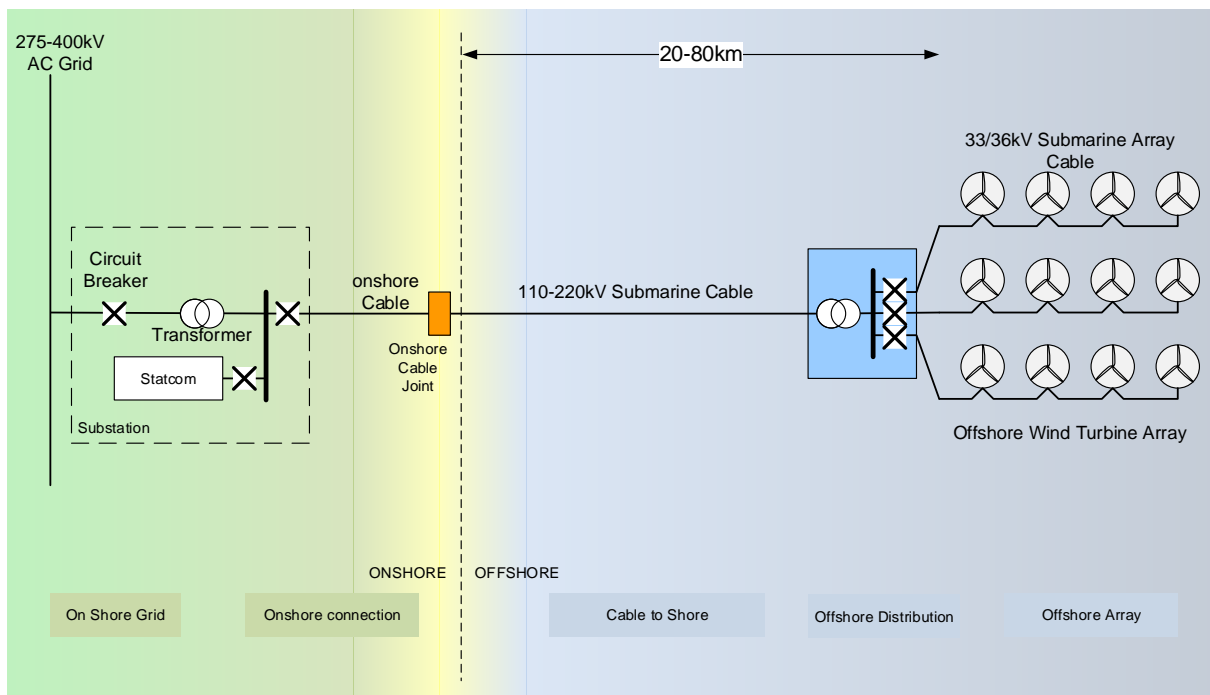

Figure 37: Illustrative HVAC connection (Source, DNV GL)

High voltage AC connections can transport considerably more power on a single HV cable (at 220kV, up to 400MVA is feasible) than MVAC connections which dramatically reduces the number of export cables required. The additional cost of the offshore substation is offset to some degree by the reduced cable costs and reduced electrical losses associated with high voltage transmission at longer offshore distances.

To date HVAC connections have been used for projects between 20-80km offshore (beyond which the charging current effects of HVAC cables become too pronounced and effectively limit real power transmission capacity of the line) and generally offer the most economic means of connecting the majority of offshore wind projects.

Advantages	Disadvantages
Allows increased transmission distances offshore.	Requires construction of costly offshore substations.
Reduced number of cables generally means lower overall cost as well as reduced rights of way.	HVAC submarine cables are costlier, and have fewer suppliers, than MVAC.
Significantly reduced electrical losses.	High impact of a single cable failure.

Table 9: Advantages and Disadvantages of HVAC connections



5.2.2.3 High Voltage DC

The final transmission technology which has been employed in the connection of offshore wind farms is high voltage direct current (HVDC) transmission. HVDC transmission necessitates the use of several transformation steps; initially converting the power from MVAC to HVAC before rectifying it to HVDC at an offshore converter station for transmission to shore. Once at the onshore connection point, the power must be inverted to HVAC once again, and transformed to the desired voltage for injection into the grid. It should be noted that the transformation of MVAC to HVAC has been to date accomplished at a separate offshore HVAC substation and not at the converter station itself; whilst under discussion, no project has yet integrated the HVAC transformation step into the HVDC converter station mainly due to the additional space requirements and the very large number of MVAC array cables which would need to connect to an 800-1000MW transmission link.

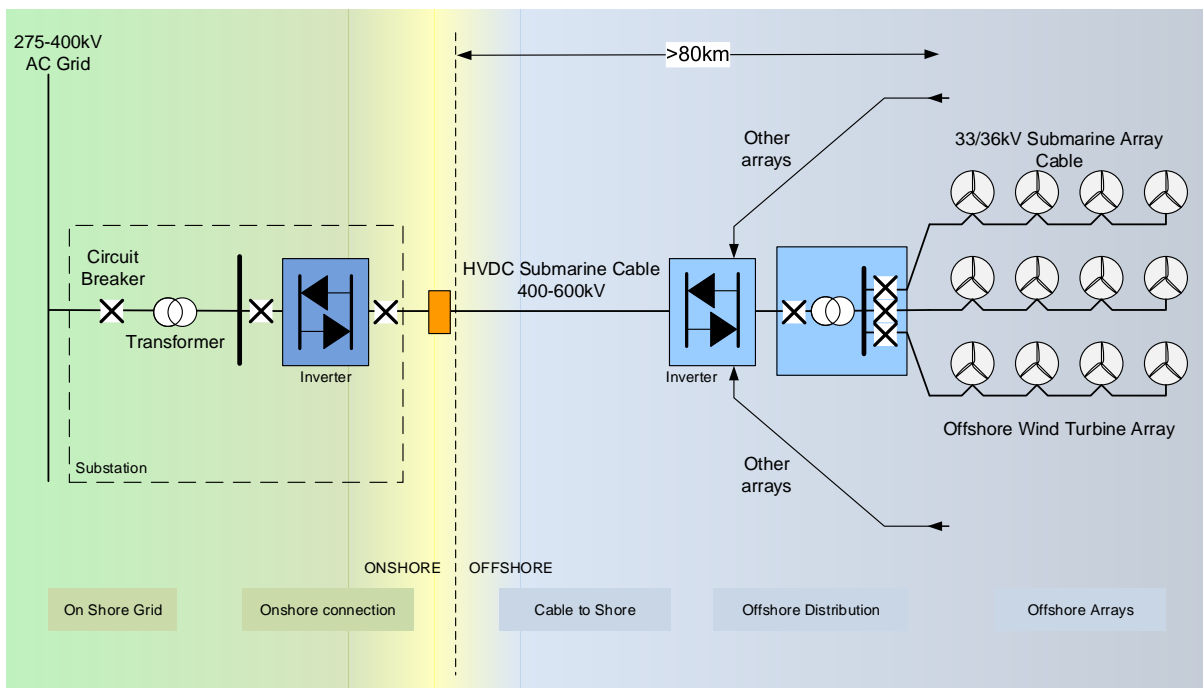

Figure 38: Illustrative HVDC connection (Source, DNV GL)

HVDC transmission is theoretically unlimited in terms of transmission distance and uses cheaper HVDC cables with a higher power rating per circuit than HVAC cables, meaning fewer are necessary. Furthermore, over longer transmission distances HVDC results in lower electrical losses when compared with HVAC (once the additional losses in the converter stations are offset by less efficient HVDC cables). HVDC transmission also permits the transmission of very high volumes of power on a single circuit, up to 900-1000MW per system.

The cost of offshore converter stations is very high however, and is typically only justified when considering very large (singly or in aggregate) offshore wind farms located so far from shore as to make the more usual HVAC transmission unfeasible. Therefore, it is unlikely that HVDC connections will prove relevant to the Indian offshore wind market in the short-medium term given the relative proximity of the identified zones to shore (and the existing grid). That said, if there are extensive transmission bottlenecks at the near-shore substations it may become feasible to construct an extended HVDC connection to an inland pooling substation.



Advantages	Disadvantages
Theoretically unlimited transmission distances.	Limited numbers of global suppliers.
Reduced number of cables generally means lower overall cost as well as reduced rights of way.	Incredibly costly offshore HVDC converter stations are required.
Can reduce electrical losses over long distances.	Very high impact of a single cable failure.

Table 10: Advantages and Disadvantages of HVDC connections

5.2.2.4 Comparison

The table below summarises the main characteristics of each connection design relative to each other, based upon typical systems. Whilst MVAC connection directly to shore represents the lowest cost design for near-shore, smaller, projects it can be seen that as projects grow in size impractical numbers of cables are required to transmit the power to shore. Furthermore, electrical losses become very significant over longer distances.

HVAC connection typically represents a good balance of cost, rating and electrical losses and is likely to be widely employed in the Indian offshore wind industry.

HVDC technology represents some advantages over HVAC but its cost is generally prohibitive for all but the largest, furthest from shore, transmission connections.

	MVAC	HVAC	HVDC
Capital Cost	Low, for shorter distances	Moderate	Very high
Losses	High	Moderate	Low, but must consider fixed losses at converters
Typical Range	0-20km	20-80km	80+ km
Single failure impact	Low; only 35MW/cable	High; up to 300-400MW/Cable	Very High; up to 800-1000MW/cable
Offshore HVAC substation	No	Yes	Yes
Offshore HVDC Converter	No	No	Yes
Number of circuits for 150MW	4-5	1	1
Number of circuits for 500MW	14-15	2	1
Number of circuits for 1000MW	28-30	3	1

Table 11: Comparison of offshore transmission technologies



5.3 Offshore Grid Topologies

In addition to selection of a transmission technology, when developing an offshore transmission system one must consider the topology of the offshore grid such that grid connections can be developed economically, in an incremental fashion, with due regard for 'future proofing' of the transmission system. There is no common approach and different jurisdictions worldwide have taken different approaches to this. This section will describe the main connection topologies and assess them in an Indian context. It should be noted that these are not necessarily mutually independent and that several models can coexist depending upon the characteristics of the offshore generation being connected and the grid to which it connects.

5.3.1 Radial

The simplest connection topology sees each individual offshore wind farm connected to the onshore transmission via its own dedicated transmission link. This is the most widely deployed offshore grid topology to date as it permits incremental build-out with minimal asset stranding risk. This approach results in limited coordination of projects however, and a 'first-come-first-serve' approach to the allocation of transmission capacity and rights of way. It is well suited to a 'developer build' model (please refer to Section 5.5 for a more detailed discussion of offshore transmission ownership models) whereby each individual party constructs its own dedicated connection assets with minimal coordination or anticipatory planning. Given the more scaleable, modular size of HVAC transmission links this has been the preferred transmission technology employed for radial offshore transmission, although smaller, earlier projects may have utilised MVAC connections if they were sufficiently close to shore.

It is likely that the first projects to be built out in any new regime, including India, will follow a radial build (at least in the first instance).

5.3.1.1 Case Study: UK Offshore Grid Topology

The UK currently has the largest installed offshore wind capacity globally [12]. Presently, all offshore wind projects have been connected to the grid via direct, sole-use radial connections which have been constructed by the offshore wind farm developer. So far MVAC and HVAC connections have been exclusively utilised but as projects are developed further from shore it is likely that HVDC connections will be developed in the future.

The image below shows the wind farm projects located off the east-coast of England and their respective transmission connections to shore. The geographic diversity of the projects as well as the presence of numerous transmission substations near the coastline has facilitated this incremental radial build out. Each connection is individually sized for the maximum wind farm output and there is no sharing of offshore transmission infrastructure between projects.

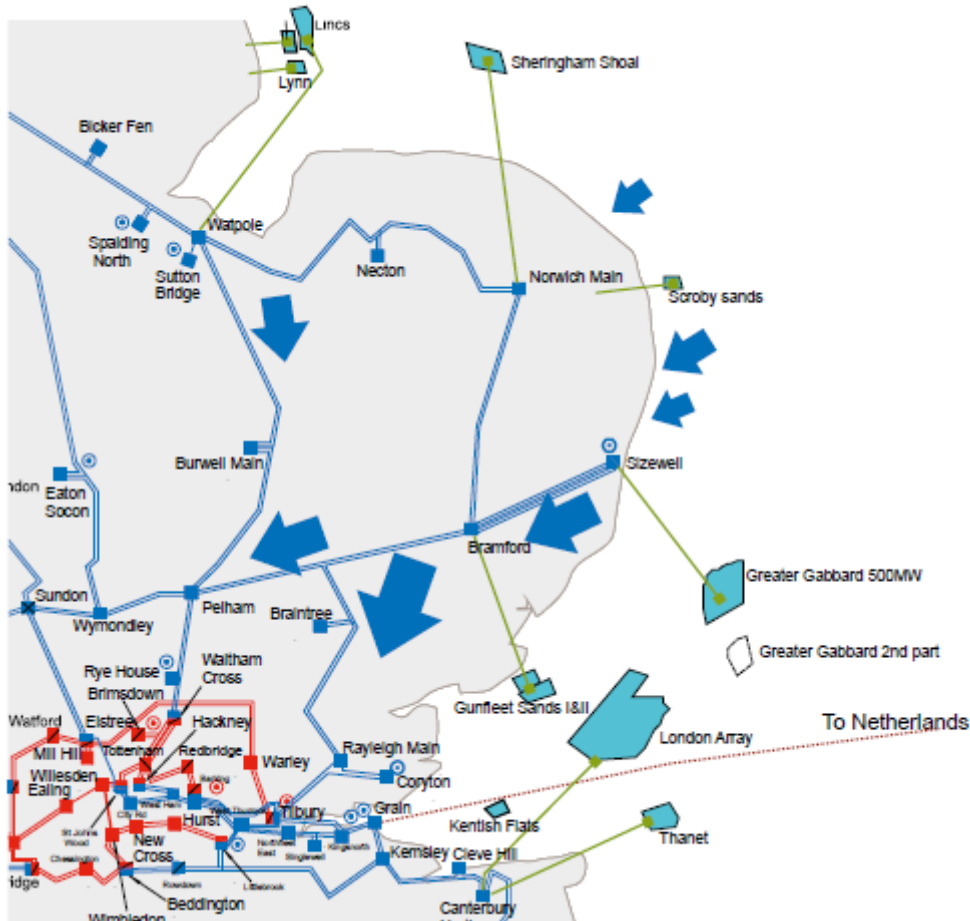

Figure 39: East of England Offshore Wind Farm Connections [33]

5.3.2 Clustering

'Clustering' of offshore generation projects implies that multiple wind farms are located geographically close enough to share transmission infrastructure. In this topology, large, high capacity transmission assets are constructed and are shared by several individual wind farm projects as their primary export route.

This approach is a form of transmission coordination, and therefore requires some element of centralised planning to determine the rating, specifications and sequencing of investment. As a consequence, it is unlikely to be achieved via a developer-build type transmission framework whereby individual projects are not strongly incentivised to invest in shared transmission capacity (or the perceived risk of doing so is too great). Furthermore, it implies that there is some element of 'anticipatory' investment; or the construction of additional spare offshore capacity in advance of all the offshore generation projects being constructed. Consequently, this approach may confer some risk of asset stranding should subsequent generators, for whom the transmission capacity is planned, not materialise (cancel their projects).

To its advantage it can confer cost benefits to the development of offshore transmission as the incremental cost/MW capacity of larger transmission projects can be lower than for dedicated radial links, as well as reducing permitting risk as fewer rights of way must be consented and removing some risk to later developers who can be assured that their transmission connection is already constructed prior to their connection.

Offshore, clustering may take the form of multiple connections to a single high capacity HVDC link, for example (see case study below).



Onshore clustering could manifest as multiple generators connected by radial offshore links to dedicated onshore pooling substations, and sharing onwards (onshore) transmission infrastructure (e.g. high capacity EHV overhead lines) to the existing intra-or-inter-state transmission systems. In India, this approach may be relevant where there are a number of projects seeking connection to the same near-shore region and where there are substantial transmission bottlenecks present; or where multiple projects are seeking connection to the more remote inter-state grid.

5.3.2.1 Case Study: German North Sea Grid Topology

The North Sea region of Germany is home to numerous offshore wind farm projects. In this region, the transmission utility (Tennet) is responsible for construction of high power transmission links from the onshore grid to offshore wind generators.

In the case of the German North Sea region, the distances offshore can be very long ranging from the 75km (800MW) DolWin 1 cluster to the 200km (864MW) SylWin 1 cluster with relatively few nearshore connection options, hence the selection by Tennet of HVDC transmission as the preferred technology. In this case, Tennet has installed large HVDC transmission links, each of which connect a number of offshore wind farms which may be developed independently of one-another.



Figure 40: German North Sea Offshore Wind Farm Connections [34]



5.3.3 Integrated/Meshed

An option for grid connection of offshore generation which has been often-discussed (but has yet to be constructed in practice) employs a topology with similar characteristics to that employed onshore. The so called 'integrated offshore grid' utilises offshore interconnections between projects with a diversity of onshore connection points in order to provide options in power export routes, potentially bypassing onshore transmission constraints and permitting any spare capacity in the offshore network to be utilised for wheeling onshore power flows.

Such a design could be employed within single networks to alleviate onshore constraints, or between different countries or grid regions to augment cross-border transmission capacity. Furthermore, the 'meshed' nature of such connections means that projects are more resilient to faults on their export cables as alternative export routes exist.

However, the implementation of such offshore grid designs necessitates a high level of coordination between multiple stakeholders and they have therefore been relatively slow to develop into firm projects. This is particularly notable where such projects cross state or regional boundaries and involve multiple transmission utilities as well as governments and offshore wind generators. Therefore, a strong planning authority and robust process is likely to be a pre-requisite for meshed grid development offshore.

Thus, such meshed designs are unlikely to be suitable for offshore wind industries in the early stages of development, but may be considered as a strategic plan where a strong needs case exists.

In the context of the FOWIND project, a region with hypothetical potential for onshore/offshore grid integration is that of the Gulf of Khambhat [25] where numerous potential development zones have been identified which are sited between the states of Gujarat and Maharashtra. In theory, offshore grid connections to these projects may connect to different regions of Gujarat, and even both states, to provide transmission capacity through an offshore network (effectively reinforcing the inter-state network) to load centres around Mumbai.

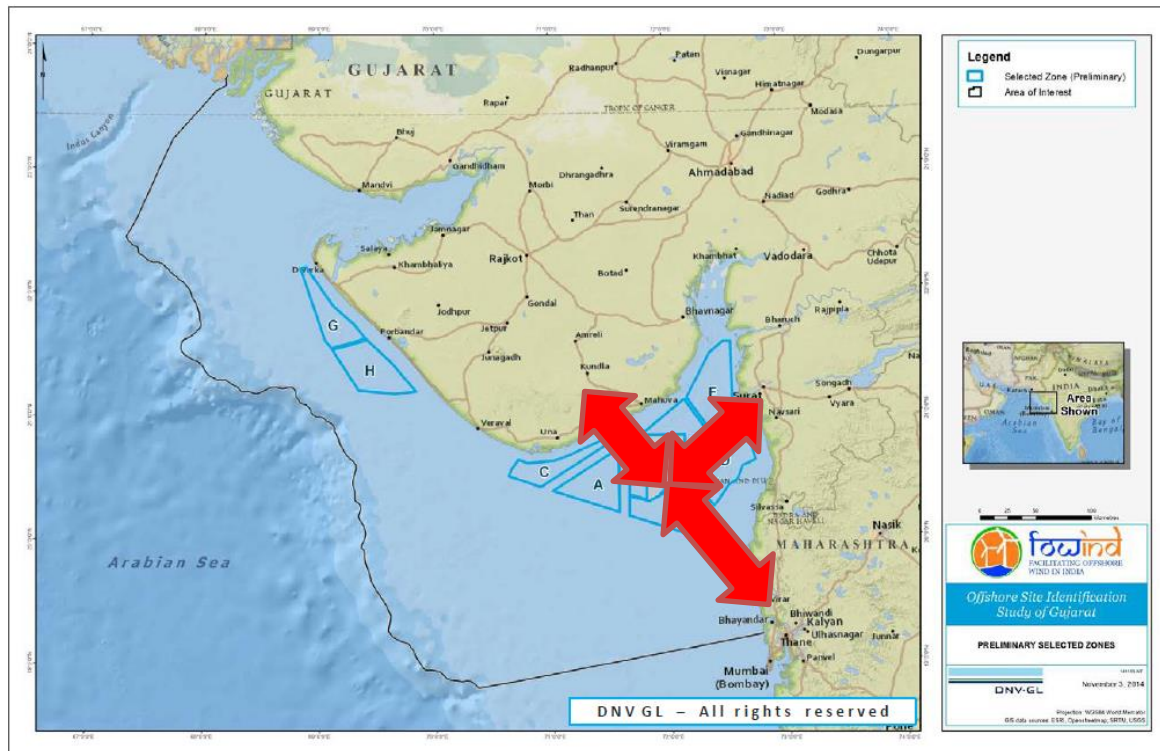

Figure 41: Potential power flows from offshore grid integration in the Gulf of Khambat [35]

5.3.3.1 Case Study: The Krieger's Flak Combined Grid Solution

The first true, integrated offshore grid proposed between two regions is the Krieger's Flak Combined Grid Solution. Adjacent to Germany, in Danish waters lies the proposed 600MW Krieger's Flak offshore wind farm. Nearby (less than 30km distant) in German waters is the 288MW Baltic 2 wind farm which is connected to the German Grid (operated by 50Hz transmission in this region) via 150kV cables and the 48MW Baltic 1 project.

Given the proximity of these neighbouring offshore wind farms it is proposed to interconnect them offshore via submarine cables between the projects' offshore platforms in order to provide an international interconnection between the Danish and German grids allowing power flows from the combined projects to be distributed between Germany and Denmark as desired and spare capacity to be used for cross-border power flows.

It is important to note that this design relies upon a back-back HVDC converter at Bentwisch in Germany as the two grids are not synchronised and this permits power flow control on the interconnection (which would otherwise not be possible otherwise, using purely AC). It is most cost effective to place this HVDC converter onshore, to eliminate the need for another large, offshore structure

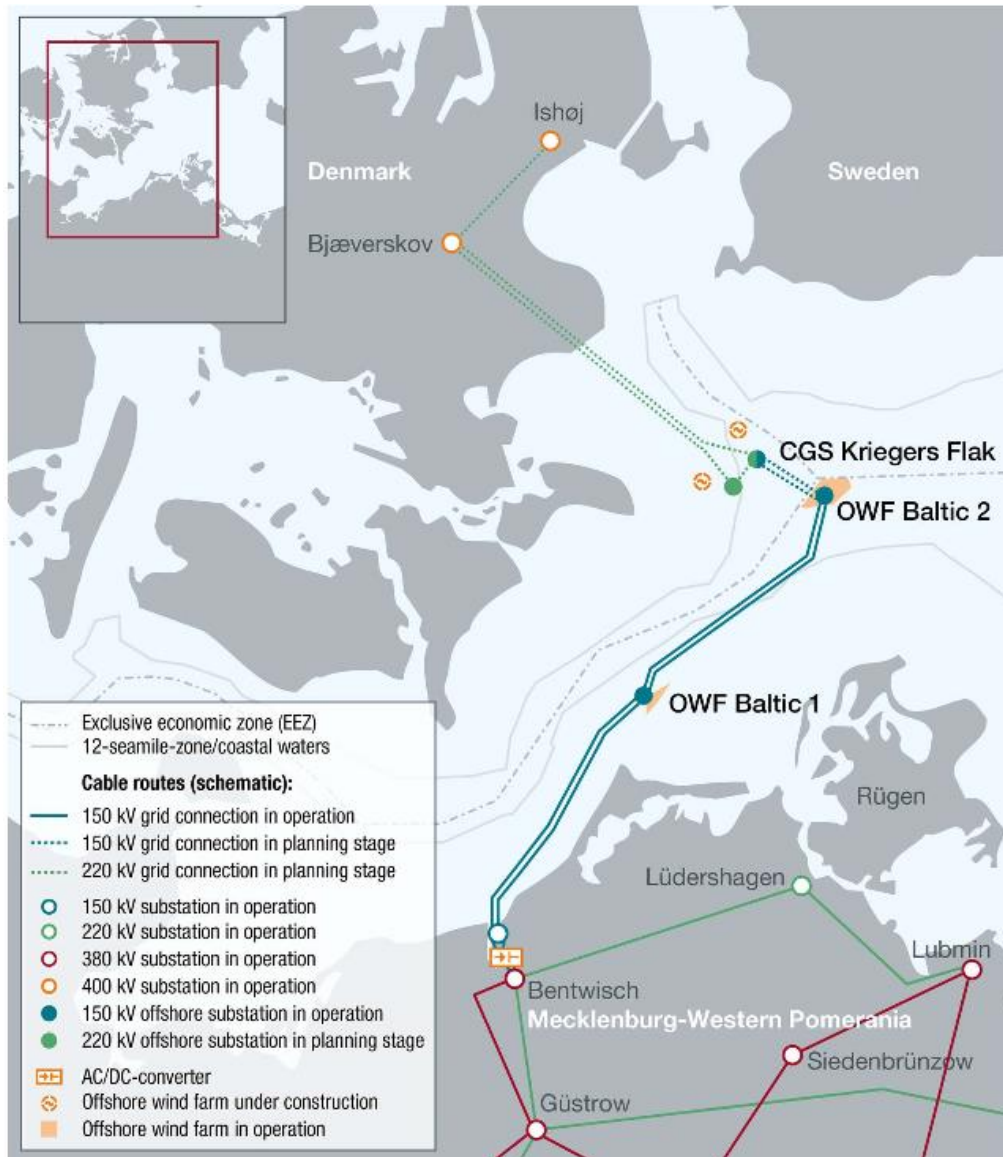

Figure 42: The Krieger's Flak Combined Grid Solution [36]

5.4 500MW Offshore Wind Farm Case Study in India

On behalf of the FOWIND project, both GETCO and TANGEDCO have conducted high level grid integration studies for a 500MW wind farm connecting to their respective systems. To accompany these a radial offshore grid connection design has been derived which could be considered illustrative of typical offshore wind grid connection practices.

Within these studies GETCO proposed a design to extend the existing onshore transmission network for the purposes of connecting a 500MW wind farm and this has been used as the basis for the offshore grid design. It should be noted, however, that everything up to the high voltage side of the 220kV onshore transformers may be considered generic (though dependent upon the length of the offshore cables required) and relevant to other connection configurations. It should also be noted that this design has not been the subject of power systems analyses therefore the exact equipment parameters may be expected to vary in a more detailed design.



5.4.1 Base Assumptions

In deriving this illustrative design the following assumptions have been made:

- A radial 220kV HVAC connection has been assumed using a single offshore substation (OSS), as this is likely to provide the lowest cost of connection in this case.
- The offshore array collection voltage has been assumed as 33kV. Individual offshore array cable connections are not shown in detail.
- The offshore cable length between the shore landing and offshore substation is 25km (consistent with Gujarat Zone A). Offshore cables utilise a copper conductor.
- There is a 5km route length onshore between the landfall and onshore pooling substation which is cabled. Land cables are cross-bonded, trefoil installed and use aluminium conductors.
- Offshore and onshore cables have been sized according to the maximum OWF output, expected charging current and reactive power load on the cables; ratings estimated from [37] & [38].
- The Point of Common coupling (PCC, for the purposes of meeting the technical requirements of the Grid Codes) will be the 400kV side of the onshore transformers at the wind farm pooling substation.
- It is assumed that STATCOMs will be necessary to meet all or part of the Grid Code voltage control requirements at the PCC.
- Subject to detailed harmonics studies, harmonic filters have been included in the design at the 220kV level.
- The 400kV pooling substation is assumed to be a double bus layout. The 220kV pooling substation is of a single-bus design.
- No redundancy has been provided in the offshore cable system or transformers, which is consistent with common offshore wind farm design practice due to the high cost of installing additional equipment offshore.



5.4.2 Single Line Diagram

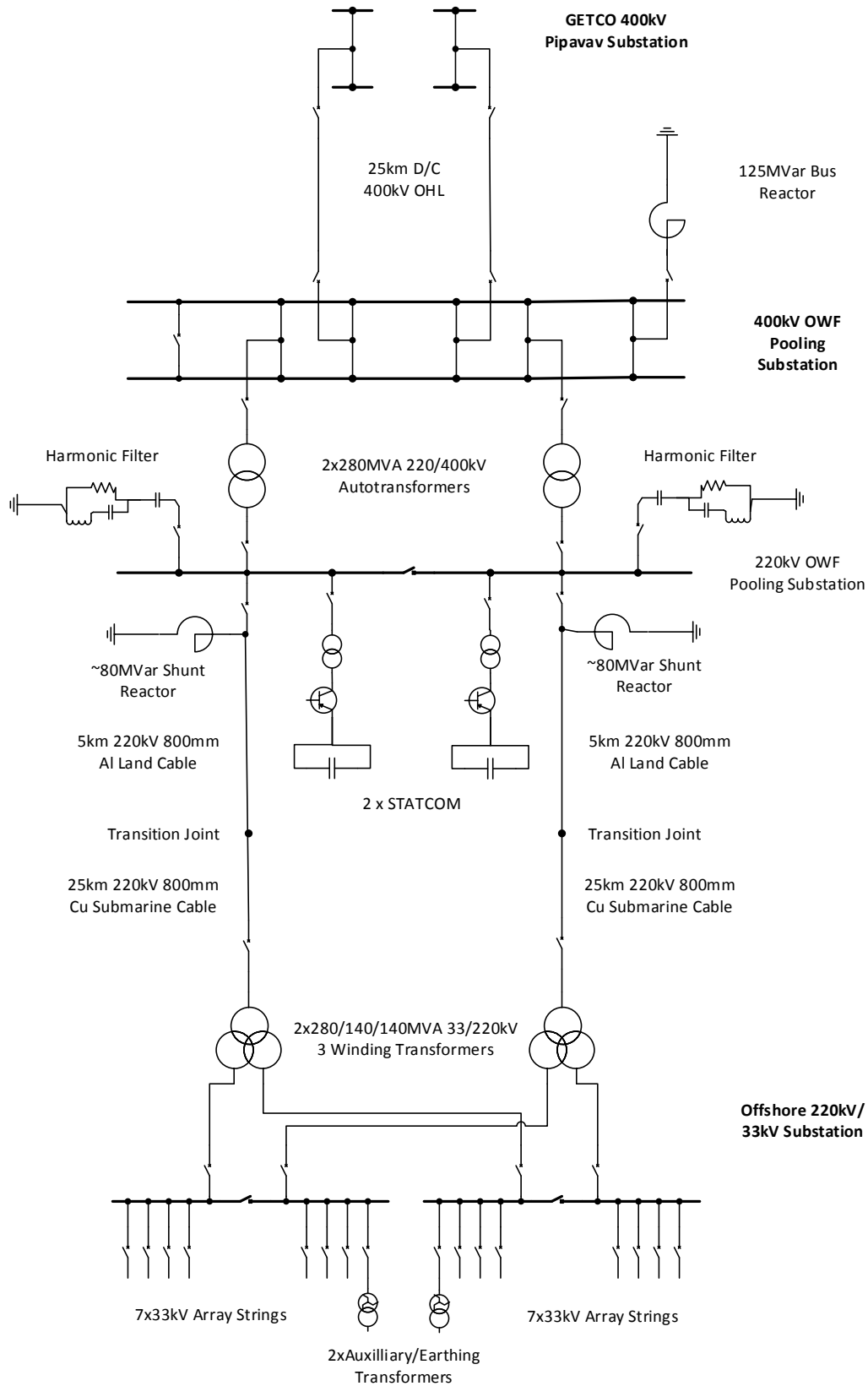

Figure 43: Illustrative SLD of a 500MW offshore wind farm connection (for clarity individual disconnectors and earth switches etc. are not shown)



5.4.3 Discussion & Rationale

The base principle of this design is that it is generally run split, as two separate radial connections to separate groups of turbines offshore; however, retaining the option to cross-couple at various points in the system to maintain flexibility in the event of system outages.

Beginning from the turbines, a 33kV array voltage has been assumed which has been common practice for offshore wind to date. This necessitates a minimum of 14 array strings to handle the full 500MW OWF output at approximately 35MW per string. It may not be feasible to lay out the array cables to perfectly balance the loads; therefore, it is possible that additional strings will be required depending upon the site layout. It is also relatively common practice to include spare 33kV bays on the offshore substation in case of cable or switchgear failure.

Connected to the 33kV busbars offshore are auxiliary/earthing transformers to provide power to the offshore substation itself and a neutral point connection for the offshore earthing system. The busbars are sectionalised to limit maximum current in the switchgear to 2500A (a relatively standard rating for 33kV switchgear). The crossover design of connection to the transformers enables the 33kV system to be reconfigured in the event of a transformer failure to allow all turbines to export through a single transformer (albeit at reduced maximum output).

2 x 3 winding MV/HV transformers have been employed which is expected to provide an acceptable balance between transformer cost and system fault levels. Alternatively, 4 x 140MVA, 2 winding transformers may be employed however this is likely to increase the cost of electrical plant and the offshore structure considerably (the offshore transformers are the heaviest item on an offshore substation and thus a key driver of structural cost). It may be possible to utilise 2 x 280MVA 2 winding transformers however 33kV system fault levels may become unacceptably high.

Limited HV switchgear has been provided on the offshore substation to minimise cost, weight and space. This is acceptable as the transformer ratings are matched to the cable ratings and may be coupled on the 33kV side so there is limited benefit to installing additional HV switchgear to cross-couple the cables offshore.

It is assumed that all cable reactive power compensation can be accomplished onshore; again to reduce the weight on the offshore topside. This is likely to be acceptable as the transmission distance is not excessive and each cable is not rated close to maximum capacity. Alternative designs for the compensation system may place additional shunt reactors offshore to compensate the cable from both ends. The onshore shunt reactors (to compensate for the cables capacitance, and ensure no reactive power exchange with the grid under normal conditions) are banked to the cables via a simple "T" connection meaning both must be energised together. This helps to manage energisation transients but if additional operational flexibility is desired the shunt reactors could also be connected directly to the 220kV onshore busbar with circuit breakers.

To comply with the technical requirements of the grid code (assuming the PCC is at the 400kV side of the onshore transformers) harmonic filters and STATCOMs are likely to be required to provide additional reactive power control and mitigate harmonic injection. It should be noted that the switched shunt reactors on the windfarm side, and STATCOMs, are likely to provide sufficient voltage control and mitigate the need for the GETCO proposed 400kV, 125MVar reactor at the HV side of the transformer.

The GETCO studies also considered a 400kV pooling station with 25km of 400kV double circuit overhead line to a new-build 400kV GETCO substation at Pipavav. Whilst this design is feasible, it may prove simpler to continue the 220kV HVAC offshore cables to the new 400kV substation at Pipavav and site the 220kV/400kV wind farm substation there instead; subject to detailed design and planning considerations.



5.5 Offshore Grid Delivery and Ownership Models

One feature of offshore wind farms that distinguishes them from the more established RES is the need to have dedicated offshore electricity transmission infrastructure. The regulatory model for the connection of offshore wind farms to the main onshore network (referred to as the 'grid connection') is critical for investment incentives in offshore technology because it governs the distribution of costs and risks between project developers, network operators and other stakeholders.

There are three main regulatory approaches that have been used to connect offshore wind farms to the onshore grid [39], [40].

Generator model

Under the generator model, the wind farm developer is responsible for the construction of the offshore grid connection and bears its entire cost. In such a model, developers have a high incentive to implement a cost-efficient connection because high cost or low availability directly affects their profits from the wind farm. The greater degree of control exercised by the developer ensures that the construction of the wind farm and the grid connection is coordinated, thereby avoiding the case of stranded assets. However, the generator model also significantly increases the project developers' costs and risks. This model has been used in Sweden for some projects.

TSO model

In the second approach, the transmission system operator (TSO) is responsible for extending the grid to reach the wind farm. This model is the dominant method for offshore grid connections in Europe and has been adopted by several countries, such as Denmark, France, Germany and the Netherlands. In Germany, for example, the responsibility for grid connection in North Sea projects is with TenneT TSO and for Baltic Sea projects with 50Hertz Transmission. The developer/operator undertakes the wind farm inner array cabling. The grid connection high voltage cables are laid, owned and operated by the respective TSO.

The TSO model in Germany was altered in 2013. In the early years of offshore wind farm development, the government obliged the TSOs to provide a guaranteed grid connection by the time the wind farm reached technical operability. The technical and financial challenges faced by the TSOs caused grid delays exposing developers to financial risks and jeopardised investor confidence in the market. Since 2013, the upgrading of the offshore transmission infrastructure follows the Offshore Grid Development Plan (O-NEP) prepared by the German TSOs and submitted to the Federal Network Agency (BNetzA). This allows for coordinated development and the possibility of wind farms sharing offshore transmission assets [41]. As a result of this change, the developer's right to a guaranteed grid connection has been replaced by an objective, transparent and non-discriminatory allocation procedure [42].

Third-party model

The third-party model is the UK's current approach to offshore grid development. A tender is run to appoint a third party as the Offshore Transmission Owner (OFTO) to build, own and operate the connection asset between the wind farm and the onshore transmission network. This model, which launched in 2009, entitles OFTO licence holders to a 20 year revenue stream, subject to a satisfactory performance, indexed to the retail price index (RPI) in the UK. The OFTOs' revenue, which comes from the National Electricity Transmission System Operator (NETSO), is independent of wind farm performance, as the transmission asset owner is only required to ensure its availability, irrespective of actual power transmitted. As the UK was previously working under a generator model, the OFTO regime applies both to the transmission assets acquired from the wind farm developers as well as to the transmission assets newly built by OFTOs. The first licence for an OFTO was granted in 2011 and by



September 2016 there were fifteen operating offshore transmission owners totalling over 4GW of connection capacity [43]. In NPV terms, the cumulative savings from the first three OFTO tender rounds are estimated to be between £672m-£1.2b (2014/15 price base) [44].

All three regulatory models are well established in Europe, and each has advantages and disadvantages as outlined in the tables below.

Regulatory Model	Advantages	Disadvantages
Generator Model	The offshore wind farm owner has an incentive to build reliable and cost efficient connections to maximise profit margins.	Places a large cost burden on the wind farm owner.
	Experienced developers are well placed to manage the development risks and ensure that operational risks associated with the grid connection life time are also minimised.	In the EU under the Third Energy Package ² legislation a generation license holder cannot own a transmission license and hence cannot own transmission assets. The developer is required to subsequently sell the transmission assets to a transmission license holder once constructed.
	The grid connection operation and maintenance (O&M) can be integrated with the offshore wind farm O&M potentially reducing costs.	
	End of life decommissioning will be combined with the wind farm decommissioning potentially reducing costs.	
	No offshore interface with the TSO, all offshore assets are owned by the developer and there is no need to segregate wind farm and grid connection assets offshore (interface is onshore).	

Table 12: Generator Model Advantages and Disadvantages

² The European Union's Third Energy Package is a legislative package for an internal gas and electricity market in the European Union. Its purpose is to further open-up the gas and electricity markets in the European Union. The package was proposed by the European Commission in September 2007, and adopted by the European Parliament and the Council of the European Union in July 2009. It entered force on 3 September 2009. Core elements of the third package include ownership unbundling, which stipulates the separation of companies' generation and sale operations from their transmission networks.



Regulatory Model	Advantages	Disadvantages
TSO Model	Potentially can reduce the cost burden on the Developer if the connection cost is paid for through use of system charges, rather than an upfront charge.	Potentially places a cost burden on the TSO if the connection cost is paid for through use of system charges ³ and financing risk where numerous connections are executed simultaneously by the same party
	The TSO can centrally plan the full network and may have the opportunity to integrate the offshore wind farm grid connection within another strategic network development such as an interconnector or a strategic network reinforcement using an offshore route. Central planning will also be of benefit where there are multiple offshore wind farms in proximity to each other.	TSO is a natural monopoly, the development of reliable and cost efficient connections is dependent on the regulatory regime and regulatory oversight.
	In the EU, the TSO model ensures compliance with the Third Energy Package, hence no requirement for the sale of transmission assets after construction.	TSOs with limited offshore network may not be as well placed as the developer to manage risks and ensure that operational risks associated with the grid connection life time are minimised.
	TSO with substantial offshore grid plans can drive supply chain efficiency savings due to the scale of procurement.	Development, construction and operational risks reside with the TSO. TSO will require suitable regulatory incentives to minimise risks while maintaining cost efficiency.
		The grid connection stranding risk potentially resides with the TSO or the electricity customers.
		There will be an offshore interface with the TSO, which may require segregation of wind farm and TSO assets offshore.

Table 13: TSO Model Advantages and Disadvantages

³ In Germany, the TSO, Tennet, had to sell shares in several offshore wind farm grid connection projects to raise the development funds required. Through this process Mitsubishi agreed to become co-financer of four of the transmission cable links.



Regulatory Model	Advantages	Disadvantages
Third Party Model	Reduces the cost burden on the Developer and the TSO.	Adds complexity to the electricity regulatory regime and the governance arrangements, codes and standards required.
	Typically, a Third-Party Model would introduce competition and downward pressure on grid connection costs compared with the TSO model.	Increased risk of third party business failures impacting on the electricity industry.
	Adds a new market opportunity for businesses.	There may be a requirement to reduce third party risks to incentivise investment. Compared with the Generator model, this transfers certain risk costs from the wind farm developer/owner to the electricity consumer.
	Provides an opportunity for investors looking for longer term investments e.g. pension funds.	Requires the establishment of a competitive O&M service provision market.
	Brings new investment into the energy supply industry.	Adds additional party interfaces compared with the Generator Model and the TSO Model where responsibilities require to be decided e.g. which party is responsible for grid code compliance with the TSO, the generator party or the third party offshore transmission owner.
	Can introduce a party who is specialised in the financing, and ongoing operation and maintenance of offshore grid assets.	
	In the EU, ensures compliance with the Third Energy Package.	Introduces the need for a competitive tender process to award the OFTO license.

Table 14: Third Party Model Advantages and Disadvantages

No single model is a perfect solution to developing and operating offshore transmission networks. However, this is an issue that must be clear in the policy laid down for offshore wind farm developments in India since it determines the cost and risks borne by the various stakeholders. For the first few projects, the OFTO model may not be the most appropriate because of the added complexities of running a separate auction. In addition to the generator and TSO model, policymakers in India could also adopt a hybrid of the two, where the developer constructs the offshore transmission network but it is subsequently handed over to the TSO.



5.6 Key Challenges for Offshore Wind in India

The challenges from this section relating to development and integration of offshore wind projects to Gujarat and Tamil Nadu's power system are given below:

- Given the (relatively) nearshore profile of the offshore wind zones identified there are no significant technical barriers to the design and construction of their associated offshore grid connections. Smaller, pilot projects close to shore may connect via direct MVAC connections in the first instance, but it is likely that HVAC will become the preferred connection technology choice as the industry matures.
- Whilst offshore transmission systems are similar to onshore systems in their general principles there are certain key differences in their relative costs and specific implications of their characteristic design; e.g. presence of large quantities of submarine cable.
- The offshore electrical industry is relatively mature worldwide and therefore there is competence and capability in design of offshore power systems available, and it is recommended to tap into this experience to build capability in offshore power systems within key stakeholders in the Indian industry in anticipation of delivery of the first projects.
- The preferred grid topology should be carefully considered, and this will be closely influenced by the chosen offshore transmission delivery and ownership model. Early projects are likely to connect in an incremental, radial fashion however this may not be the long-term optimum model. However, a higher level of coordination between the planning of multiple offshore grid connections and the onshore transmission system requires that a more centralised offshore grid planning function be defined.
- Whilst an illustrative 500MW offshore grid connection is presented, it should be noted that variation of any parameters (size, location, connection point etc) is likely to influence the system design and this should not be taken as a default 'blueprint' for the design of offshore wind grid connections in India. There is likely to be scope to further optimise the interface between the onshore and offshore power systems.
- The policy on the delivery and ownership of the offshore transmission network needs to be a high priority since it determines the cost and risk structure for the project developers and the TSOs.



5.7 Recommendations

Key recommendations drawn from this chapter are summarised below:

Sub-Objective: Facilitate offshore grid development for the integration of offshore wind		
Barrier	Mitigation	Key Stakeholders
No policy exists for delivery and ownership of offshore transmission systems.	Select either generator built or TSO built model for ownership of the first offshore wind projects Initiate a Central Working Group to frame an enduring national offshore transmission policy	CEA, CTU, STUs MoP, MNRE, CEA
No framework exists for offshore transmission network planning.	Initiate a Working Group to evaluate the optimal transmission topology and system planning regime for Gujarat and Tamil Nadu.	CEA, CTU, STUs
There is limited experience in India for the planning, design and construction of offshore transmission systems.	International consultants may fill the gap in the short term. A longer term roadmap for development of local competencies should be devised.	CTU, STUs

Table 15: Offshore Grid Development Recommendations



6 SYSTEM OPERATION

6.1 Introduction

Renewable generation like wind and solar are characterised by their generation variability, intermittency, and potential limited contribution to system inertia. Hence the large scale integration of renewables in a power system usually creates new system operational challenges like forecasting, variability management, balancing, requirement of additional reserves and ancillary services etc.

This section explores the specific power system operation management challenges that could affect the development and operation of the proposed offshore wind projects in Tamil Nadu and Gujarat. The common operational issues at a national level are identified first and then specific issues related to the respective states. The impacts of these operational issues on development and operation of offshore wind projects are discussed and recommendations provided.

6.2 Power System Operational Issues in National Level

The Indian power system is a single synchronous grid interconnecting all the five regional grids as shown in Figure 44 [45].

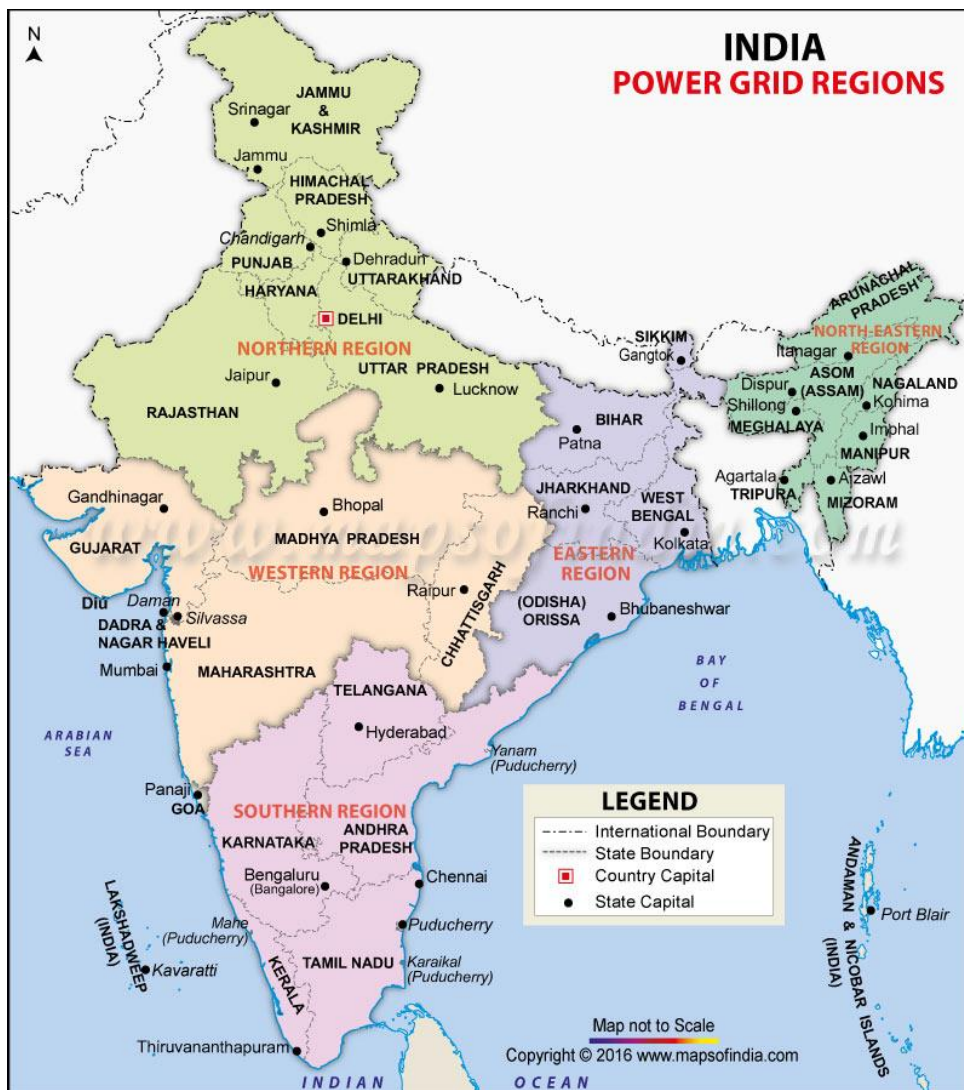

Figure 44: Power grid regions



The five regions of the national power system are namely southern, western, eastern, north-eastern, and northern grid. Each of the five regions has a Regional Load Dispatch Centre (RLDC) which is the body which ensures the integrated operation of the power system in the relevant region. The RLDCs are monitored by the NLDC. Each state has a SLDC which is the apex body to ensure integrated operation of the power system in the state. The states could have Area Load Dispatch Centres (ALDC) at various locations within the state, which are governed by the SLDCs.

The power system operation and management in India is a complex task and the system has significant voltage and frequency fluctuations as well as blackouts. These issues are further complicated by the large scale integration of renewable energy in the transmission and distribution systems. Some of the key issues faced at national level are provided below:

6.2.1 Frequency Instability

The grid frequency is unstable due to several reasons on both the generation and consumption side. The RLDCs and SLDCs are solely responsible for achieving a grid frequency via dispatch management and regulations. Both distribution companies and generation companies have been deviating from their agreed drawal or injection schedule which causes deviations in frequency.

Frequency management is achieved nationally in three steps. The first is primary reserve (inertia of rotating generation and load damping) is responsible for sudden changes in grid frequency. The second step is the use of fast acting generating plants like hydro, gas etc. to provide balancing power in short term. The third step is to activate tertiary reserves which can support and sustain the actions of the secondary reserve. At present, there are almost no reserves to manage the frequency and in the absence of a functional capacity market, the generators (both conventional and RES) are not given any incentives to keep their spare capacity for reserve purposes. The generators will naturally try to generate at their maximum capacity to maximise their revenue. Besides this, availability of secondary reserves is significantly constrained by seasonal unavailability of hydro plants and a shortage of gas supply in gas power plants.

6.2.2 Lack of Generation Reserves

The IEGC mandates a primary reserve level of 5% at national level. However, it is understood that this is not fully materialised in practical operations. The actual primary response is understood to be less than the ideal response or declared response of the generators. One of the reasons for this limited response is that the generators are not maintaining adequate reserves at their maximum (or economical) operating point. Second reason for the non-compliance is technical difficulties for generators at plant level. The Indian power system has not implemented secondary control via automatic generating controls. The generation reserves are an important requirement to ensure the system is stable during various system events and aids the management of variability in renewable generation.

6.2.3 Forecasting and Scheduling of Renewable Plants

The accurate forecasting of renewable generating stations is important for ensuring grid stability and security in grid operations. This also helps to accurately predict the generation at renewable station level and thereby assisting the individual stations to enhance their income by accurate scheduling as well as reduced penalty for deviation settlement. Renewable forecasting is still in a nascent state in India and forecast errors can be up to $\pm 30\%$ [46]. CERC has issued a model regulation for forecasting, scheduling, and imbalance settlement at inter-state level and such regulations are also envisaged in intra-state level.

This model regulation suggests two levels of forecasting: One, the relevant SLDC shall mandatorily undertake renewable forecasting in order to ensure secure grid operation and to plan requisite balancing resources. Secondly, the renewable stations shall perform station level forecasting for their own



purposes. They have an option to accept SLDC's forecast for preparing its schedule or provide the SLDC with a schedule based on their own forecast. Any commercial impact on account of deviation from schedule based on the forecast shall be borne by the renewable generators. Large scale renewable integration has prompted the system operators to set up Renewable Energy Management Centres (REMCs) to establish or attached to existing regional and state dispatch centres. The renewable forecasting is one of the key functions of this unit.

6.2.4 Inaccuracy of Load Forecasting

POSOCO has identified that poor load forecasting is one of the three reasons for power schedule deviations. Besides that, conventional generators are understood to be not strictly complying with their schedules and the renewable sources show high variability. Two separate studies conducted in Tamil Nadu and Gujarat indicate that deviations from load forecasting and conventional generators as not complying with their schedule as larger than the deviations caused by wind power variability [46]. This indicates the importance of accurate load forecasting techniques applied along with renewable energy generation forecasting.

6.2.5 Inadequate Balancing Sources and Insufficient Balancing Mechanisms

A coordinated multilateral dispatch model is practised in India. The power system balancing is undertaken mainly at state level by the respective SLDCs. Each DISCOM and SLDC are required to commit sufficient generating reserves to meet the anticipated load and renewable generation. The states need to forecast and ensure adequacy of generation on a day ahead basis and a balanced portfolio needs to be maintained at state level at different time frames. Due to several reasons, such as limited flexibility thermal generation, a lack of hydro or pumped hydro capacity, a lack of gas based power plants, variability of renewables, forecast errors in demand and renewables etc. causes significant stress on SLDCs to balance their respective systems. The regional or inter-regional balancing has to be developed in future in order to achieve larger scale integration of renewable energy generation. The National Electricity Plan for 2017-22 envisages enhancement of flexibility in existing fleets of conventional generation, pumped storage plants, and demand side management for a better system balancing. Regulatory intervention shall be required to incentivise the flexibility of conventional generators, with special attention to their minimum and maximum technical generation levels and ramping up and down rates.

6.2.6 Inter-State Settlement for Large Scale Renewable States

The current regulatory norms are not fully developed for establishing deviation limits for inter-state and intra-state entities, especially for large scale renewable states. This is limiting the selling of excess renewable energy outside the host state. A regulatory framework is required for intra-state deviation, metering, accounting, and settlement mechanisms amongst different entities including renewables on priority basis.

6.2.7 Lack of Flexible Market Mechanisms

The present electricity market in India is in a nascent stage and mainly governed by the Power Market Regulation Act 2010. Generation, transmission, and distribution are unbundled. The State Electricity Boards (SEB) hold a major stake in transmission and distribution sectors. However, the generation sector has significant participation from the private sector. There are two functioning power exchanges in the country, which allows consumers to bypass DISCOMs and buy power at the spot market. The percentage of power traded in the exchange is very low and mainly limited to short-term contracts to manage daily variations in demand. There is a need for more frequent market clearing in power exchanges and new products such as real-time markets, flexibility markets., capacity markets etc.



6.3 Action Plan at National Level

The MoP published a report of the technical committee on 'Large scale integration of energy, need for balancing, deviation settlement mechanism and associated issues' proposes a detailed action plan to tackle various operational issues of large scale renewable integration. These action plans clearly show a roadmap for further developments in the power sector and hence the importance of considering the development of a vibrant offshore wind energy sector. Table 16 summarises the list of action items [46]. Note that FOWIND is not able to track the progress of implementation of these items in any public documents.

No.	Required Action	Action By
1	Load Forecasting as per IEGC Section 5.3	All States
2	Demonstration of Adequacy of Balanced Portfolio	All States / SLDCs
3	Regulatory Framework for Intra-State Settlement System and Imbalance Handling Mechanism	FOR / SERCs / SLDCs
4	Regulatory Framework for Forecasting of Renewable Generation and Scheduling and Implementation at inter-state level	CERC, NLDC, RLDCs, RE Generators, REMC
5	Regulatory Framework for Forecasting of Renewable Generation and Scheduling including Aggregators and implementation at intra-state level	SERCs / FOR / MNRE, SLDCs, RE Generator, REMCs
6	Regulatory Framework for Reserves	SERCs
7	Regulatory Framework for Ancillary Services Operation,	CERC, RPCs, NLDC, RLDCs
8	Implementation of Frequency Response (Primary Response).	CERC All Generators
9	Regulatory Framework for Secondary Response (AGC)	CERC, SERCs
10	Technical Standards and Protection Requirements for Renewables such as LVRT, FRT, etc. & implementation	CEA, CTU, STUs, RE Generators
11	Market Design – Frequent clearing, more opportunities, New entities (Aggregators)	MNRE, CERC
12	Regulatory Framework for Communication in Power Sector, Availability of Real Time Data at the SLDCs/RLDCs/NLDC particularly of RE generators	CERC, RE Generators, SLDCs, POSOCO
13	Implementation of Renewable Energy Management Centres (REMCs)	CTU, STU, SLDCs, RLDCs, NLDC



No.	Required Action	Action By
14	Standards and Regulatory Framework for incentivising "Flexibility" in Conventional Generation	CEA, CERC

Table 16: Key action plans for facilitating large scale renewable integration

6.4 Power System Operational Issues in Gujarat

The power system operational issues described at national level apply largely to the state of Gujarat as well. This section provides an overview of specific operational issues in the state and their bearings on proposed offshore wind development and operation.

The generation mix of Gujarat as on March 2016 is compared against the planned generation mix at the end of 2021-22 as shown in in Figure 7. This indicates that in March 2016 around 80% of installed generation (thermal, gas, and hydro) is available for balancing 17.5% of total wind and solar generation in the state. By March 2022, it is projected that only 54% of installed generation (thermal, gas, and hydro) will be available for balancing around 43% of wind and solar generation. Hence it is imperative to understand the current operational challenges brought by renewables and how they could affect the development and operation of offshore wind generation. Table 17 summarises the specific system operational issues faced in Gujarat. These issues are based on a comprehensive literature survey, stakeholder interviews and the use of FOWIND's experiences in development and operation of onshore wind and solar generators in the state.

Technical Constraints
<ul style="list-style-type: none"> ▪ The state has a vast potential for wind energy in the Saurashtra region. With large variations in wind generation in this region, the power flow constraints are observed in certain transmission lines between North Gujarat and South Gujarat (in 2014-15 periods). The critical paths are: <ul style="list-style-type: none"> ○ 400 kV Dehgam- Sami D/C, ○ 400 kV Dehgam- Pirana D/C, ○ 400 kV Dehgam- Jhanor, ○ 400 kV Jhanor- Haldarva [46].
System Balancing
<ul style="list-style-type: none"> ▪ Inability of thermal generation to reduce generation in the case of high renewable generation. The minimum load for thermal plants in the state is reported to be between 40%- 80%, with a capacity weighted average around 62% [47]. ▪ Unavailability and high cost of gas has limited the generation from gas-based power plants to load factors of around 5%-25% [48]. Hence these plants are often not available or dispatch for balancing purposes.
Forecasting and Variability Management
<ul style="list-style-type: none"> ▪ SLDC has managed to receive day-ahead wind forecast information from all intra-state plants and conducting an area level forecast based on eight zones. Though results are encouraging, the accuracy needs to be improved. ▪ POSOCO has conducted studies on standard deviations of hourly load and net load (demand



minus renewable generation) with three years of data, between the 2012-2015 period. The results indicate that the reserve requirement has gone up by 150 MW over the three years. Since the renewable capacity is projected to reach 43% of total installed capacity by 2021-22, such studies need to be conducted to estimate the required reserve capacity [46].

- A separate study conducted by POSOCO indicates that the deviations in power scheduling due to inaccurate demand forecasting and conventional plants not adhering to schedule is larger than the deviation due to wind generation variability [46].

Curtailement

- Current renewable forecasting and system balancing techniques has helped SLDC to manage the grid without much stability issues. Conventional generators are used to reduce output on merit order basis, subject to their technical minimum loading. The gas plants are used during sudden drops in wind generation. The load shedding is activated only on rare conditions through equal percentage of reduction in load in each feeder. Hence renewable curtailment is minimal. However, wind generators are asked to reduce their generation occasionally when the transmission system is unable to evacuate power.

Scheduling, Dispatch, Deviations Settlement

- Traditionally, imbalance handling on the Indian grid has been done through the Unscheduled Interchange (UI) or the Deviation Settlement Mechanism (DSM) framework, in which the frequency-linked UI rate provides a signal to the grid participants to correct for instantaneous frequency deviations. However, this has led to a use it was not intended for. At present the threshold of allowed deviation limit within the deviation settlement mechanism is 150 MW or 12% of schedule (whichever is lower). In Gujarat, deviations in the range of 1174 to -1162 MW were observed in 2015. The state argues that in consideration of the peak load and renewable penetration, the existing limits are too low and hence should be raised [46].

Table 17: Power system operational challenges, Gujarat

6.4.1.1 Implications on Offshore Wind Sector Development and Operation

The operational challenges in a power system will equally affect onshore wind/solar and offshore wind generation. However, there are certain aspects where offshore wind generators can positively affect the system operation (compared on onshore wind and solar), like larger size, higher capacity factor, better accuracy in generation forecasting, better reactive power control, ability to support ancillary services etc. The key implications of current operational challenges on offshore wind sector development and operations are given below:

- Offshore wind power integration in Saurashtra region could create evacuation problems in the west-east intra-STC corridor during high wind conditions because the higher share of wind resources is located in the western part of the state, including Saurashtra and Kutch. A complete system study of the state together with all inter-state transactions should be conducted to verify such bottlenecks.
- The relative geographic spread of onshore wind, solar, and offshore wind in Gujarat could effectively reduce the renewable generation variability and hence help the system operator to balance the system.



6.5 Power System Operational Issues in Tamil Nadu

Tamil Nadu is the state in India with the largest installed wind capacity. 37% of the generation capacity comes from renewables (March 2016). The growth of wind generation is primarily driven by very favourable wind conditions in the generation pockets in the state. Due to the significant presence of renewable capacity and associated variability, Tamil Nadu is facing many unique operational challenges that many other states are not facing in addition to the broader issues identified at the national level.

The generation mix of Tamil Nadu as of March 2016 is compared against the planned generation mix at the end of 2021-22 and as is shown in Figure 10. The percentage of renewables in the generation mix in the state is projected to increase to 44% from the current level (March 2016) of 37.5%, while the available balancing capacity (from thermal, gas, and hydro) is projected to decrease to 50.1% from the current level (March 2016) of 54%. Hence unlike Gujarat, Tamil Nadu doesn't show significant changes in generation mix in the coming years.

Table 18 summarises the specific operational issues faced by Tamil Nadu due to increasing penetration of renewables.

Technical Constraints
<ul style="list-style-type: none"> ▪ Major wind generation pockets in Tamil Nadu are located in the southern part of the state, in places such as Tuticorin, Kayathar, Tirunelveli etc. The 400 kV and 230 kV substations in the nearby area are unable to evacuate wind power because the DISCOM demands are already met. This in turn overloads the 110 kV substations and trip the transmission lines and result in the curtailment of wind generation. At present, wind generators are required to connect to 400 kV or 230 kV substations or it is a requirement that the existing lines in are strengthened in order to ensure reasonable power evacuation. ▪ A significant number of wind farms are equipped with old turbines or asynchronous generators which draw reactive power from the grid and pose voltage instability issues. Moreover, many of these wind farms are connected at weaker grid areas and thereby can cause disturbances in the transmission and sub-transmission grid. ▪ Power flow constraints exist in several sections of the intra-state network and network strengthening is envisaged on a priority basis. ▪ Many wind turbines are not equipped with LVRT protection or not comply with the LVRT characteristics as prescribed in CEA connection standards. Hence these wind turbines are very sensitive to grid events in Tamil Nadu and partially, the rest of the Southern region. The Southern grid has many cascading outages and severe oscillations in inter-regional interconnectors where root cause is identified as lack of LVRT compliance [49].
System Balancing
<ul style="list-style-type: none"> ▪ Tamil Nadu receives high wind during the monsoon season which is a low-demand period. During this time, the reservoirs in hydro plants become full. The thermal generators are limited to their technical minimum limits or completely shut down for their annual overhaul and maintenance. In these circumstances, the majority of demand is met by hydro, wind, and nuclear plants and all of these are designated as 'must run'. The sudden variability of wind generation under this situation poses significant system balancing issues. SLDC has limited options to ramp up and down generation as this is limited to hydro and pumped hydro generators. The ramping up and down for thermal plants below 60% is not technically feasible. All these events lead to system



<p>instability and security conditions [49].</p> <ul style="list-style-type: none"> ▪ In dry season, the hydro generation is limited as most of the reservoirs need to serve long term irrigation needs. At this time, the available flexible generation options are further limited. Due to various technical and commercial reasons, SLDC is not able to reduce the power generation from thermal generators and the central pool beyond a specific limit. This situation leads to wind curtailments.
<p>Forecasting and Variability Management</p>
<ul style="list-style-type: none"> ▪ A pilot renewable forecasting project has been launched with assistance from NIWE. Though the results are positive, the accuracy is not at expected levels [46]. The system operator is resorting to wind curtailments whenever necessary stating 'grid instability and security' reasons. Load shedding is also practised to manage variations. ▪ A separate study conducted by POSOCO indicates that the deviations in power scheduling due to inaccurate demand forecasting and conventional plants not adhering to schedule is larger than the deviation due to wind generation variability [46].
<p>Curtailment</p>
<ul style="list-style-type: none"> ▪ Curtailment is practised by SLDC in order to maintain grid frequency. ▪ Wind variability, forecasting errors, lack of flexible generation, inability of thermal generators to reduce output, a lack of dedicated wind evacuation lines etc. all contribute to serious wind generation curtailments [50].
<p>Scheduling, Dispatch, Deviations Settlement</p>
<ul style="list-style-type: none"> ▪ Traditionally, imbalance handling on the Indian grid has been undertaken through the Unscheduled Interchange (UI) or the Deviation Settlement Mechanism (DSM) framework, in which the frequency-linked UI rate provides a signal to the grid participants to correct for instantaneous frequency deviations. However, this has led to uses not intended. At present, the threshold of allowed deviation limit within the deviation settlement mechanism is 150 MW or 12% of schedule (whichever is lower). In Tamil Nadu, deviations in range of 546 MW to -990 MW are observed in 2015. The state argues that considering the peak load and renewable penetration, the existing limits are too minimal and hence it must be raised [46].
<p>Reserves and Ancillary Services</p>
<ul style="list-style-type: none"> ▪ The wind farms located in southern districts are mostly connected at a voltage level of 220 kV or below. During high wind seasons, the voltages in southern Tamil Nadu are critically low, mainly in the 400 kV Udumalpet S/S, 400 kV Madurai S/S, and 400 kV Tirunelveli. This indicates a lack of local reactive power support. The state has taken measures to implement under voltage load shedding schemes at selected feeders [46]. ▪ The Tamil Nadu Electricity Board (TNEB) has not implemented contingency demand disconnection schemes to counter power flow variability and this causes over-demands from rest of the regional grids [49].

Table 18: Power system operational challenges, Tamil Nadu



6.5.1.1 Implications on Offshore Wind Sector Development and Operation

Due to the significant penetration of renewable generation, Tamil Nadu is facing a lot of power system operational challenges resulting in severe renewable curtailments. Since the offshore wind plants will be integrated within the high onshore wind zones, these current issues will have an implication on the offshore wind sector development and operation. As mentioned earlier in this report, offshore wind generators can positively affect the system operation (compared with onshore wind and solar), like larger size, higher capacity factor, better accuracy in generation forecasting, better reactive power control, ability to support ancillary services etc. The key implications of current operational challenges in the offshore wind sector development and operation are given below:

- Offshore wind generation in the southern part of the state will face similar operational challenges and curtailment events to that of onshore wind generation. Adequate power evacuation corridors are required to alleviate the current problems.
- Renewable curtailment events shall be necessary if the security of the system operation is at risk. However, lack of transparency of renewable curtailments and related uncertainties could be challenging for development and operation of offshore wind generators.
- Spatial and temporal smoothening effects of onshore wind, offshore wind, and solar generation shall be beneficial for the state operation as large scale solar and offshore wind are expected to be integrated in short to medium terms.

6.6 Recommendations

Key recommendations drawn from this chapter are summarised below:

Objective: Ensure stable system operation with increasing penetration of offshore wind and other RES		
Barrier	Mitigation	Key Stakeholder
Incomplete/delayed enforcement of national action plan for facilitating large scale renewable integration (Section 6.3)	Rigorous follow-up and timely enforcement of identified mitigation measures	NLDC, RLDC, CTU
Uncertainty around the absolute level of grid curtailment at present and expected in the near future	Measure, report and set targets on curtailment levels	CERC, RLDCs, SERCs, SLDCs
Limited experience in system operation with increased penetration of RES	Review the international practices and implement knowledge exchange/ capacity building programs to fulfil the gaps in the short term Long term roadmap for development of local competencies	NLDC, RLDCs, SLDCs

Table 19: Key recommendations for system operation



7 TECHNICAL AND REGULATORY CODES

7.1 Grid Connections

In order to connect to the power system and export energy in India, a renewable developer is required to secure firstly, Grid Connectivity, and subsequently, Grid Access. Grid Access may be granted on a short, medium or long term basis. For the purposes of offshore wind projects, which require significant capital investment and therefore certainty over their route to market for generated energy, it is assumed that Grid Access will be sought on a long term (up to 25 year⁴) basis only.

Depending upon whether its energy will be consumed within the state of connection, or outside the state, an offshore wind farm must decide whether it shall apply for access to the Inter-State (provided that the installed capacity exceeds 50MW, which is assumed to be the case for offshore wind projects) or Intra-State power system. It is not feasible that large offshore wind farms will connect to the distribution system.

The following table summarises the key institutions and documents relevant for seeking application to the state or national transmission systems.

	Inter-State	Gujarat	Tamil Nadu
Nodal Agency	Central Transmission Utility (PCGIL)	State Transmission utility (GETCO)	State Transmission utility (TANGEDCO)
Regulating Body	Central Electricity Regulating Agency (CERC)	State Regulating Agency (GERC)	State Regulating Agency (TNERC)
Open Access Regulations	Grant of Connectivity, Long-term Access and Medium-term Open Access in inter-State Transmission and related matters) Regulations, 2009 & Amendments	Terms and Conditions of Intra-State Open Access Regulations, 2011	Grid Connectivity and Open Access Regulations 2014
Relevant Grid Code	Electricity Grid Code (2010) & Amendments	Gujarat Electricity Grid Code (2013)	Tamil Nadu Electricity Code (2005) & Amendment
Connectivity Threshold	≥50MW	≥4MW	≥15MW
Re-application trigger	+/-100MW change	+/-10% change	+/-10% change

Table 20: Key institutions and documents for application to transmission system

⁴ The typical technical lifetime of offshore wind projects is 20-25 years.



A high level process flow for the grid connections process is illustrated below.

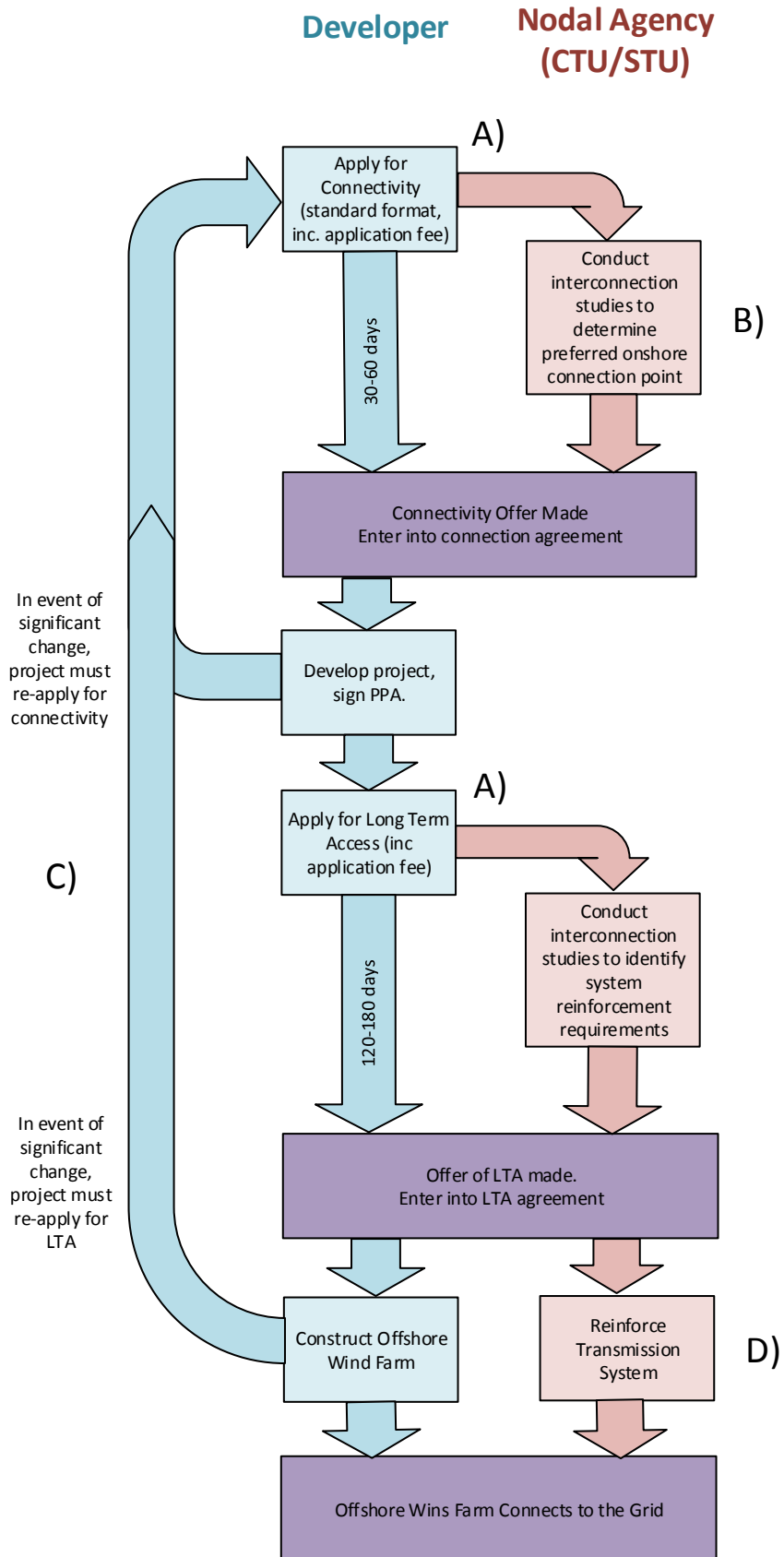

Figure 45: High Level Grid Connection Process Flow



In Figure 45, four process steps have been identified as particularly relevant in the case of an offshore wind project:

A) Submission of Connectivity/LTA Application

The general format for connectivity and LTA applications may need to be revisited slightly for offshore wind projects; notably the data and parameters which should be included in an application. One aspect concerns the location of the generator which is applying, which in the case of offshore wind projects will be some geographical coordinates in the ocean, and the relevance of these for the purposes of processing an application; i.e. how will the nodal agency interpret/use this information in granting connectivity to a specific onshore substation and is there any additional information from an offshore developer necessary to support the process?

The supporting application documentation may also need to be reviewed considering the specific nature of an application from an offshore project. An example is shown below [51]:

- *Additional information to be submitted by Generating Station*
 - (i) *Site identification and land acquisition*
 - (ii) *Environmental clearance for the power station*
 - (iii) *Forest Clearance (if applicable) for the land for the power station*
 - (iv) *Fuel Arrangements*
 - (v) *Water linkage*

The nature of land acquisition and environmental clearances are likely to be different for an offshore generator than an onshore generator therefore guidance as to the appropriate supporting documentation in the case of an offshore generation project would be beneficial.

Furthermore, if environmental clearances need to be granted to the developer for elements of the transmission interconnection (forming part of the offshore generation project) this may not be possible to achieve in advance of grant of connectivity and thus identification of the interface substation onshore.

B) Assessment of Connectivity Application

When applying for connectivity, the relevant nodal agency must consider the most appropriate point on the transmission system to connect the project. In the case of an offshore wind farm, the distance from shore (and therefore to the existing transmission grid) means that numerous potential onshore connection points may need to be considered. In optimising the connection, the nodal agency should make certain assumptions about the offshore grid (e.g. number of cables, cable route, connection voltage etc.) so that the best possible connection design can be identified and minimise the risk of subsequent changes to the onshore connection point being required.

This introduces numerous additional permutations into the connection point identification process and in such an instance, 60 days (30 days in Tamil Nadu) may be insufficient to conduct all the necessary options assessments and studies. Prior to large scale offshore wind implementation, it is recommended to review this application process and timescales, and potentially publish guidance as to how an application from an offshore developer will be treated. This process will also need to harmonise with the chosen offshore transmission delivery model in Section 5.5.

C) Application Change Process

It is to be noted that resubmission of a new application is required should the quantum of power vary significantly from that which was first applied, or if the geographic location of the project



changes. The long lead time of offshore wind projects (relative to onshore wind projects) and the increased number of variables from operating in an offshore environment mean that it has been commonplace (in other markets) for the installed capacity to be refined as project development progresses. For example, this may be due to:

- New site survey data (e.g. geotechnical)
- Human or environmental constraints (e.g. shipping)
- Development of new turbine technology

As such, for offshore wind projects to be successful, grid application and variation processes should be sufficiently flexible to enable such changes in installed capacity, recognising the impact of such changes on the wider power system, without putting disproportionate risk upon the grant of connectivity/LTA and the project as a whole.

D) Reinforce Transmission System

Large transmission system reinforcement projects can involve very long lead times; particularly the construction of new overhead line routes where permissions and rights-of-way must be obtained.

It has been indicated that the typical lead time of the CTU//STU for such reinforcement may be 3-4 years from the grant of LTA. Given that, from financial close, an offshore wind project may be delivered in 2-3 years (depending upon the scale and complexity) this could represent a slight disconnect in timescales and is likely to determine the critical path of the project as a whole.

Further, any delay in delivery of said reinforcements could expose the offshore project to extensive curtailment, thus increasing perceived risk for investors.

7.2 Grid Code

Grid codes are key technical documents which govern the relationship between those that own, operate, use and connect to the electrical system. These are necessarily public documents, available to all potential industry stakeholders, to inform the design and planning of generation and demand connections, as well as system operation, coordination and facilitation of functioning power markets.

Key areas which are typically addressed in Grid Codes:

- Defining the roles and responsibilities of the various stakeholder organisations.
- Providing the minimum technical requirements for connecting to the Grid.
- Providing guidelines for planning and development of power systems.
- Defining the operational philosophy for the power system.
- Defining rules for scheduling and dispatch of generation and load.

This section will focus on technical requirements of the grid codes, in as much as they will influence connection of large scale offshore wind to the respective state or national transmission systems.

7.2.1 The Grid Code Landscape in India

Given that the Indian power system encompasses both inter-state (national) and intra-state (within state) transmission systems. Consequently, the technical requirements for connecting to the Grid may vary depending upon whether a connection is at the inter-state level, as well as between different states.



There are also common requirements which operate at a national level across all inter and intra-state connected generation. This is illustrated in the diagram below, highlighting key documents at both a national level, and within Gujarat and Tamil Nadu:

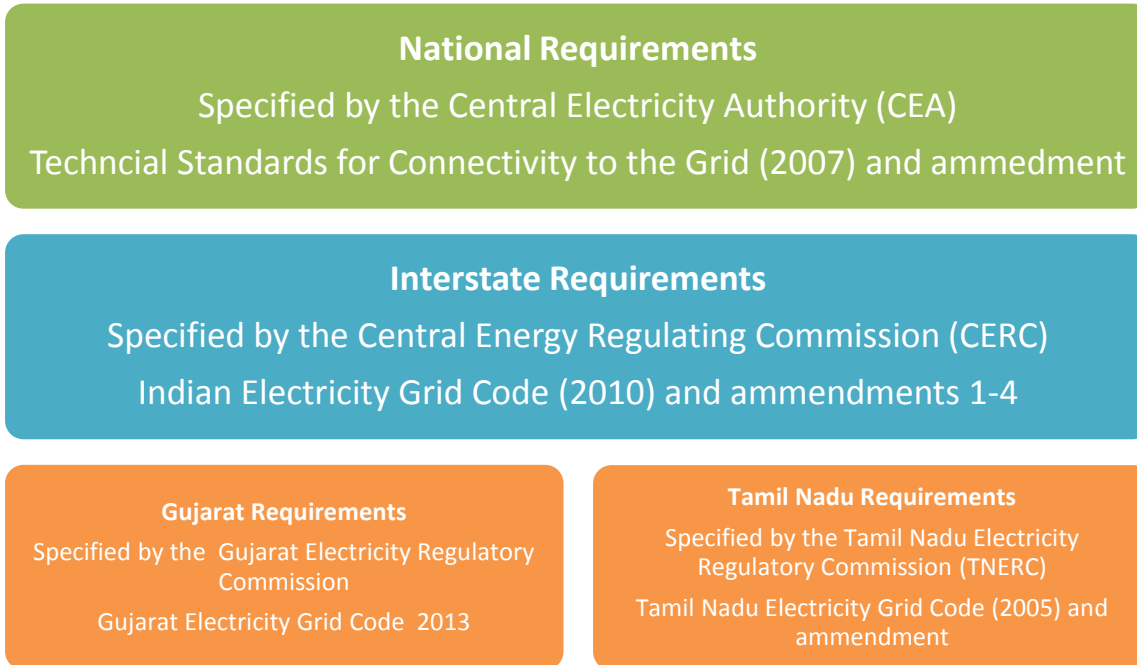

Figure 46: Key National and State Level Grid Codes.

The **National Requirements** apply to all users, applicants, the Central Transmission Utility (CTU) and State Transmission Utilities (STU's) seeking connection to the Inter or intra-state power systems. These regulations define the technical and design criteria to be satisfied at the interface of any connection to the Indian power system.

The **Inter state Requirements** define the technical requirements for all parties seeking direct connection to the Inter-state transmission network (only) and the Central Transmission Utility (CTU), referencing the CEA regulations. As well the technical requirements at the connection interface, the IEGC defines the connections process, planning process, operational rules, roles and responsibilities and scheduling rules applicable to the inter-state network (only).

At the **State Level** the individual state regulating bodies define separate Grid Codes which apply to all parties seeking connection to the intra-state power system. As per the Electricity Act, 2003, such state level codes must be consistent with the Inter-state code defined by CERC and therefore are generally similar in content and format.

7.2.2 Current Technical Requirements

As larger volumes of RES are integrated into power systems worldwide, it has become necessary to impose more rigorous connection conditions upon such generators in order to ensure reliable and stable operation of the grid. The technical requirements imposed upon generators (including renewable, specifically offshore wind generators) can have significant bearing upon the design, cost and feasibility of developing such projects. A well-defined Grid Code should ensure that such stable operation can be achieved via the definition of reasonable standards which share the burden of maintaining grid stability across all users and system operators without bias; whilst recognising the specific characteristics, limitations and costs incurred by different generating technologies in meeting such requirements.



This section provides an evaluation of key elements of the current suite of technical requirements as they apply to offshore wind generators. A comparison is also provided with regards to established regimes containing appreciable volumes of offshore wind energy (namely, Germany and the UK).

7.2.2.1 Voltage/Frequency Ranges

The voltage and frequency range within which the grid operates is the most basic technical requirement to be met when connecting a generator to the power system. It is essential that under 'normal' operating conditions (as defined in the Grid Code) that users can remain connected. Similarly, generators should detect frequency deviation which may be indicative of disconnection (islanding) from the main power system and disconnect to protect themselves and locally connected loads. These may vary between power systems and the defined ranges may impact the design or suitability of certain generators or technologies.

As defined in the Connectivity Regulations, all transmission connected wind generators anywhere in India shall be capable of operating continuously at full output in the frequency range of 49.5-50.5Hz, and remain connected (although power reduction is permitted) between 47.5-52Hz [52].

The normal voltage operating range is dependent upon the nominal voltage, and specified in the Indian Electricity Grid Code (IEGC) [53]. Given the size of offshore wind generating stations (100+ MW) it is considered that these will not connect to the power system at 66kV or below but are more likely to connect at or above the 220kV voltage range.

Voltage – (kV rms)		
Nominal	Maximum	Minimum
765	800	728
400	420	380
220	245	198
132	145	122
110	121	99
66	72	60
33	36	30

Figure 47: Voltage operating ranges for connection to the Indian power system [53]

Slightly different voltage ranges may be defined in respective state grid codes which has a bearing on the design of interfacing equipment (e.g. tap changer ranges). Gujarat observes the ranges defined within the IEGC however Tamil Nadu applies slightly different ranges at the interface with their system.

<u>Nominal</u>	<u>Maximum</u>	<u>Minimum</u>
Voltage in (kV rms)		
400	440	350
230	245	200
110	120	100

Figure 48: Voltage operating ranges for connection to the Tamil Nadu power system [54]

IEC 61400-1 defines 'normal' voltage operating ranges for all wind turbine generators as +/-10% therefore the ranges specified in the various Indian Grid Codes investigated are consistent with this standard [55]. Furthermore, offshore wind farms are normally connected behind grid interface transformers including an on-load tap-changer to regulate offshore grid voltages. Therefore, voltage deviation seen at the wind turbine terminals under normal conditions will be relatively small.



Another important, related parameter is the maximum instantaneous change in voltage (voltage step) that may be experienced on the system; i.e. faster than voltage regulating actions such as tap-changing. This is defined within the Connectivity Regulations as $\pm 1.5\%$ of nominal voltage (for frequent switching operations) and $\pm 3\%$ for infrequent contingency events [56]. Due to the fact that offshore wind farms are generally connected at the end of large cables, voltage step changes can become amplified at the offshore end however relatively modest step changes are unlikely to cause significant difficulty.

This, as well as impacting the voltage fluctuations which may be imposed upon a generator from the power system, will impact the design of the offshore transmission system in as much as switching of large capacitive or inductive loads (e.g. offshore cable systems and shunt reactors, typical of large offshore wind connections) which cause sudden step changes in local voltage profiles. In such instances, it may be necessary to split large reactors into smaller units or implement alternative energisation strategies such as simultaneous energisation of cables and reactors, in order to respect the voltage step change limits.

7.2.2.2 Voltage/Reactive Power Control

A basic consideration of power system operation is the ability to regulate reactive power flows on the network in order to manage system voltages and respect the voltage range criteria outlined in the previous section.

One of the principle methods employed to control of voltage on the power system is requiring regulation of reactive power output by generators. Typically, this is measured at the interface between the generator and the transmission system. The volume of reactive power required is normally specified as a function of generator capacity and/or instantaneous output.

In the Indian Grid Code wind farms are currently required to operate in a range of 0.95 leading to 0.95 lagging which is fairly typical of ranges in other regimes worldwide. This requirement is illustrated graphically in Figure 49 for a 500MW wind farm, where a generator has to be able to export or absorb at least the level of reactive power indicated on the chart.

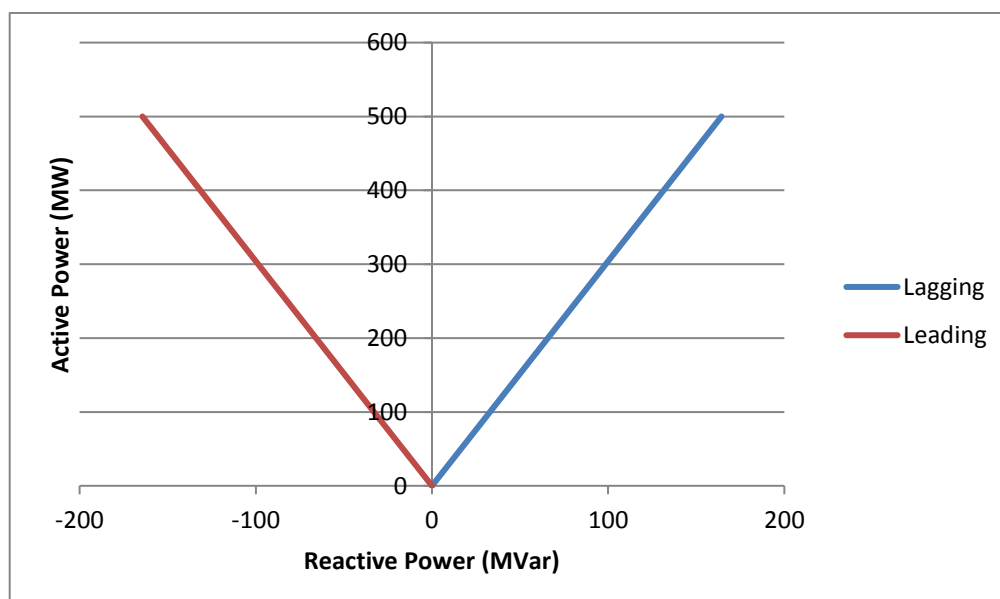

Figure 49: Minimum reactive power control requirements in India for a 500MW offshore wind farm



Modern offshore wind turbine generators all have some capability to deliver or absorb reactive power from the grid. Specifically, all currently available offshore wind turbines are of the Type 3 and Type 4 design (Doubly Fed Induction Generators or Full Converter machines respectively, with the vast majority being of the more flexible full converter design) [30].

However, depending upon the range of control required by the Grid Code, it may not be possible to meet the full range of requirements under all conditions. Therefore, it is often necessary to install additional compensating devices (e.g. STATCOMs or SVCs) at the interface boundary in order to meet the Grid Code. These devices are physically large and capital intensive plant items, particularly for larger projects located further from shore (where the contribution of the turbines is limited by the length of cable) and therefore the cost of such devices must be factored when a) designing the project and b) setting more onerous Grid Code requirements.

7.2.2.3 Frequency/Active Power Control

When demand exceeds generation, system frequency falls. When generation exceeds demand, system frequency rises. In order to maintain continuous balance between generation and demand, power systems normally require automatic regulation of power output from some generators via governor control.

A relatively new requirement upon wind generators, the Indian Grid Code currently only mandates that wind generating stations have the facility to control active power in relation to a setpoint (issued by the appropriate load dispatch centre). The technical parameters (e.g. deadband, droop, response time) of such a service are not further specified.

Many other grid codes require wind farms to have the capability to regulate power output in response to system frequency. This is relatively simple to accomplish for high frequency events, where a reduction in output is required which is accomplished via controller action and turbine blade pitching. For low frequency events, however, the ability of a wind generator to increase output is limited by the availability of the primary energy source; the wind. As wind farms will always tend to operate at the maximum output permitted by the wind speed there is no headroom to increase output in response to a low frequency event. There are currently two options to achieve a low frequency response from wind turbines:

1. Dispatch-down the wind turbine generators to below maximum output enabling them to increase power upon demand.
2. Install co-located energy storage to supply active power frequency response when required.

Both of these options result in large costs to the wind farm in either lost production or in additional construction costs therefore have not been employed widely to date and wind is not generally obligated to perform low frequency response services (although may be required to or at least have the capability of doing so). It is conceivable that with increasing renewable penetration and decreasing storage costs option 2 may become favoured in the future and enable wind to provide low frequency response and actively participate in ancillary service markets.

7.2.2.4 Fault Ride Through (LVRT)

Faults on the Grid are generally accompanied by a voltage dip. The fault ride through requirement in Grid Codes ensures that generators are able to remain connected during the fault, and continue to provide voltage support to the grid in order to prevent cascading failure.



A challenging requirement on older fixed speed and stall regulated wind turbines, current DFIG and full converter machines all possess some measure of fault ride through capability and are able to meet modern grid codes for renewables.

The fault ride through requirement in India was introduced in the 2012 amendment to the CEA connectivity requirements for 66kV and above connected renewable generators [52] (see Figure 50). For the duration of the fault the turbine must continue to feed in as much active power as allowed by the retained voltage, and maximum reactive current, to support the Grid through the fault.

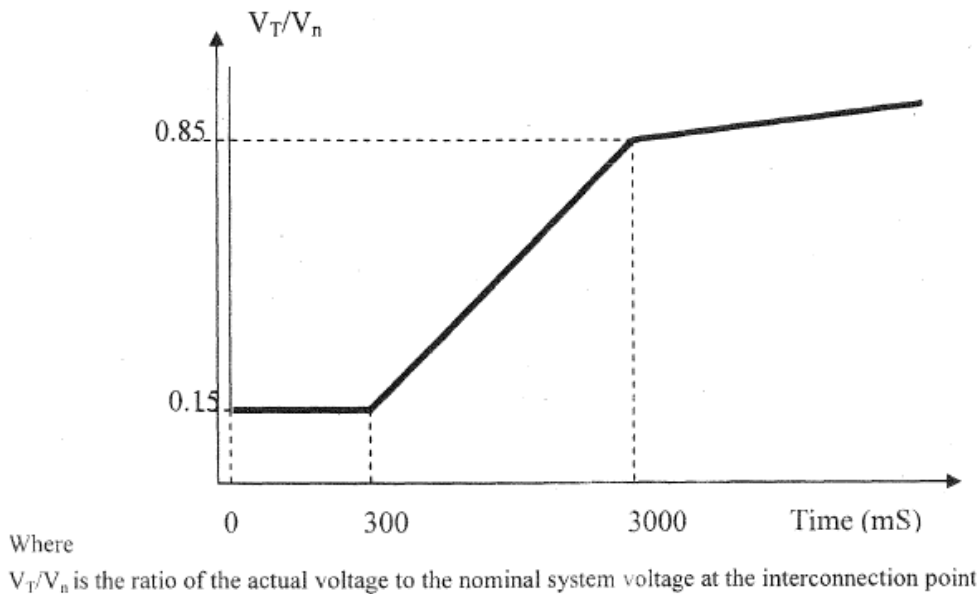

Figure 50: Current low voltage ride through (LVRT) requirements for renewable generators in India. Generators must stay connected for voltage dips less severe that illustrated by the black line [52]

LVRT capability is a function of the wind turbine design; particularly the design of the controller; and therefore is implemented by the turbine manufacturer. As the specific low voltage profile often varies from Grid Code to Grid Code it is commonplace for turbine manufacturers to undergo testing of their products fault ride through capability when entering a new market where slightly different requirements may apply, and this is likely to be true of offshore wind turbines entering the Indian market unless an equivalent rigour of testing has been conducted elsewhere and that this is deemed acceptable.



Figure 51: A turbine undergoing LVRT testing (source: DNV GL)

7.2.2.5 Harmonics

Sources of voltage distortion in modern power systems are numerous. In a typical offshore wind farm principle sources of harmonics are:

- Converters installed in the wind turbines
- FACTS devices, e.g. SVC/STATCOM (if installed for reactive power control)
- Resonant conditions amplifying background distortion⁵

In order to protect other system users and assets, Grid Codes specify limits to harmonic distortion which may be experienced at any interface to the Grid. The limits applied in India are specified in IEEE Std 519 [57]. The limits applied in India are specified in IEEE Std 519 [57], an example of which is presented in Figure 52.

Maximum harmonic current distortion in percent of I_L						
Individual harmonic order (odd harmonics) ^{a, b}						
I_h/I_L	$3 \leq h < 11$	$11 \leq h < 17$	$17 \leq h < 23$	$23 \leq h < 35$	$35 \leq h \leq 50$	TDD
< 25°	1.0	0.5	0.38	0.15	0.1	1.5
25 < 50	2.0	1.0	0.75	0.3	0.15	2.5
≥ 50	3.0	1.5	1.15	0.45	0.22	3.75

Figure 52: Current distortion limits for systems rated above >161kV [57]

Consequently, wind power projects seeking connection to the Grid must conduct studies in order to determine whether their harmonic injection on top of background levels exceeds levels permitted in the Grid Codes. If they do, it will be necessary to introduce filtering at the connection point to mitigate this. Such studies must consider:

- Harmonic impedance loci at the PCC (typically supplied by the transmission utility)

⁵ This is particularly relevant for offshore wind farms where resonance between large inductive transformers and long capacitive cables can lead to amplification of relatively low order background harmonics which can be difficult to mitigate. Furthermore a large number of potential operating configurations are possible for large offshore wind farms leading to numerous potential resonance conditions which may also interfere with wind farm controllers.



- Background harmonic levels at the PCC (typically supplied by the transmission utility)
- Short circuit level at the connection point (typically supplied by the transmission utility)
- Plant harmonic emissions spectra (provided by equipment suppliers)
- Nearby, planned 3rd party generation project harmonic emissions and plant configurations (provided by 3rd party developers, via the transmission utility)
- Different internal power system operating configurations (determined by the developer)

Provision and accuracy of such comprehensive data sets by multiple parties can be a bottleneck to project development and detail design and project delays as well as expensive retrofit solutions have been experienced in other offshore wind markets as a result. To mitigate, a clear responsibility and timeline for provision of this data and completion of harmonics studies should be clearly agreed between relevant stakeholders and specified in the Planning Codes.

A further important consideration is the allocation of harmonic 'headroom' over background levels. The normal 'first come, first served' approach to harmonic mitigation means that early projects may be able to connect with no mitigation, using up the 'headroom' over background levels. Subsequent projects connecting in the same geographic area may then need to install large, expensive filtering solutions. It may be considered to implement some form of harmonic 'allocation' process via the transmission utility to share the burden of harmonic mitigation more fairly amongst nearby RES generators where significant volumes of renewable power are planned to connect in the same vicinity, such as the identified offshore wind zones in Gujarat and Tamil Nadu.

7.2.2.6 Comparison

	India	Gujarat	Tamil Nadu	UK	Germany (Tennet)
Frequency Ranges	48.5-50.5Hz (continuous) 47.5-52Hz (limited operation)			47.5-52Hz (continuous) 47-47.5Hz (temporary)	49-50.5 (continuous) Varying short term requirements depending upon severity of frequency excursion between 46.5 – 53.5 Hz.
Voltage Ranges	<u>≥400kV:</u> +/- 5% <u><400kV:</u> +/- 10%		<u>≥400kV:</u> +5%, -10% <u><400kV:</u> +/- 10%	<u>400kV:</u> +/- 5% <u><400kV:</u> +/- 10%	<u>155kV:</u> +/- 10% (155kV is the standard offshore connection voltage)



	India	Gujarat	Tamil Nadu	UK	Germany (Tennet)
Voltage Step	Frequent: 1.5% Infrequent: 3%			Frequent: 3% Infrequent: +5%/-12%	Not Specified
Voltage Control	0.95 lag/lead			0.95 lag/lead (calculated upon maximum generation)	0.96 lag 0.93 lead (calculated upon maximum generation)
Frequency Control	Required, but technical conditions are not prescribed in the Codes.			Required to be capable of frequency control services (but may not be required to do so) according to set point and droop provided by TSO.	Required to retain full output for LF events. Capable of linear power reduction for HF events of 40%/Hz between 50.2-52.7Hz.
Fault Ride Through	15% retained voltage for 300ms, increasing linearly to 85% over 3s			15% retained voltage for 140ms, increasing to 80% over 1.2s then to 85% over 2.5s.	0% retained voltage for 150ms followed by linear increase to 90% over 1.5s.
Power Quality	Specified in IEEE Std 519 [57]			UK specific ER G5/4 (based upon IEC 61000)	Specified in IEC 61000

Table 21: Comparison of Grid Code requirements in Tamil Nadu, Gujarat, the UK and Germany

In summary, the grid code requirements in India are consistent with, or in several cases less severe (e.g. reactive power control), than equivalent requirements in the UK or Germany where offshore renewable penetration is relatively high. Thus, the current suite of technical requirements are unlikely to present a barrier to wider offshore wind implementation in India.

7.2.3 Draft Grid Code Modifications

In 2016, CEA published a draft revision to the 2007 Connectivity Regulations [58]. These regulations propose modifications to the existing Connectivity Regulations, several of which will affect the development of offshore wind farms. At the time of writing, these modifications have not been implemented. This section will discuss the relevant proposed modifications and qualify their potential impact on offshore wind generators.



7.2.3.1 Active Power/Frequency Control

CEA proposes to enhance the frequency response requirements upon wind generators; defining in detail the performance characteristics of such response (which were previously somewhat vaguely specified, Section 7.2.2.3).

The proposed modifications include a specified governor droop and dead band for frequency controllers, and that the response should be available between 10-100% of active power output.

Ramp rates are also specified, and wind generators must be capable of limiting ramp rate of power increase or decrease to 10%/minute. For power, Type 3 and 4 turbines such as are employed in offshore wind farms this level of ramp rate control is feasible, however achieving this for power reduction may be constrained by meteorological conditions; i.e. if the wind falls more rapidly than 10%/minute the turbine power output will similarly drop more rapidly than proscribed unless it is being heavily curtailed in advance of wind speed reduction.

A more significant proposal is the introduction of a rapid frequency response for significant ($>0.3\text{Hz}$) sudden frequency deviations. It is proposed that wind generators should provide an immediate frequency response of at least 10% of maximum supply capacity within 1 second of the frequency deviation, effectively mirroring the inertial response of conventional generators. This is a very challenging requirement and may be met via two possible mechanisms:

1. **Synthetic Inertia:** the use of inverter control mechanisms to inject excess energy into the grid, ultimately extracting this energy from the rotational energy of the turbine blades. This is a short duration response and as the blade speeds reduce more rapidly than the pitch control system can act, the turbine moves to a sub-optimal rotational speed relative to prevailing wind speed meaning power recovery can be slow following delivery of this response. There have been successful trials of such controller mechanisms [59], but it is not yet widely used and may be unable to provide the 10% requirement at lower wind speeds.
2. **Energy Storage:** The installation of large energy storage systems collocated with offshore wind generators would enable this requirement to be met. However, the large size of offshore wind generators (500MW and above, potentially) means that very large storage systems would be required at a significant cost. As the cost of storage continues to fall this option may become more economic, however given the large volumes of rotating, synchronous plant likely to remain connected to the Indian power system for the foreseeable future this may not be the most effective means of delivering such frequency response.

If the intention of this modification is to introduce such a 10% 'inertial' type response on ALL large wind generators this would need to be very carefully considered, and could add significant cost and risk to offshore wind projects in India.

7.2.3.2 High Voltage Ride Through

High voltage ride through (HVRT) is similar in principle to low voltage (fault) ride through. Simply put, a connected generator is expected to remain connected for the duration of a significant 'voltage swell' event which could be caused by the loss of a large local load, for example. The proposed profile of such a voltage swell to be proscribed in the Grid Code is illustrated in Figure 53.

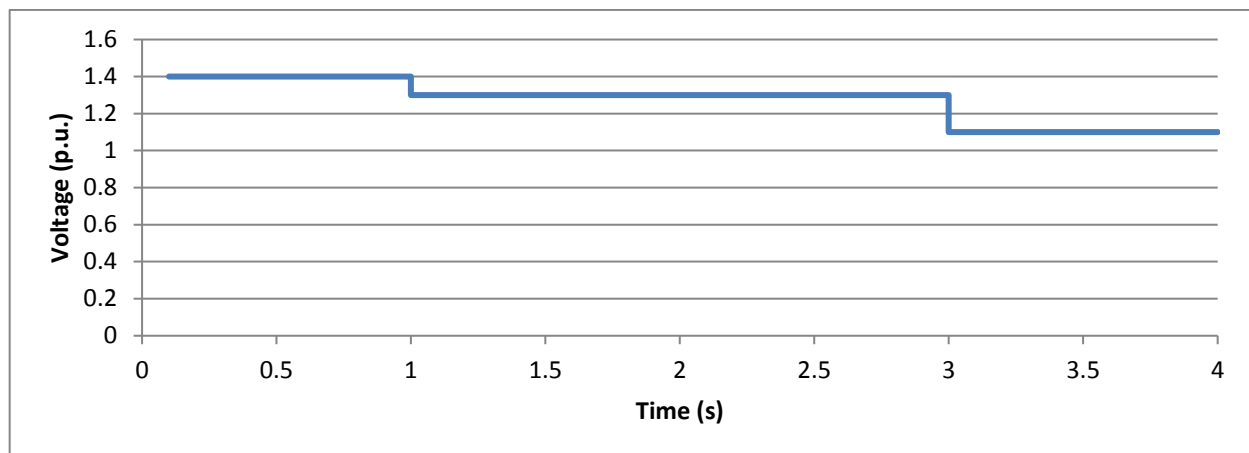

Figure 53: Proposed HVRT Profile

HVRT is not widely implemented in Grid Codes with significant volumes of offshore wind today. That said, this is unlikely to be a barrier to the implementation of HVRT for offshore wind farms and HVRT is implemented in grids with significant onshore wind penetration (e.g. Australia).

Offshore wind farms are generally connected via an interfacing transformer with on-load tap changer, therefore any gradual voltage swell will be partially compensated via tap changer action (within the range of the taps) and sudden step changes by automatic voltage control functions of the turbines and FACTS devices.

Furthermore, all components of the electrical system should be type tested to temporary power frequency overvoltages within the range specified in the proposed modifications and therefore should be resilient to the additional voltage stress. It should be noted, however, that due to the long submarine cables necessary to connect offshore wind farms the voltage rise at the offshore cable end may exceed 1.4p.u. and this should be carefully studied at the design stage to ensure that wind turbine controller strategies for HVRT are compatible with the specific onsite conditions experienced for an offshore wind farm.

7.2.4 Offshore Grid Codes

7.2.4.1 Offshore Grid Code Development

Regions where significant volumes of offshore wind have been developed have developed specific requirements upon offshore generating stations reflecting the characteristics of the technology in terms of:

- Planning data and processes
- Technical performance
- Regulatory regime in which it operates

Considering both Germany and the UK, where considerable volumes of offshore wind have been successfully delivered and the technical and regulatory codes are relatively mature, significant changes have been enacted for the purposes of connection of offshore wind. In the UK, sweeping changes to Grid (and other) codes were made following the implementation of the offshore transmission regulatory regime in 2010 [60].

In the German North Sea market, a separate, dedicated offshore grid code has been implemented by Tennet, the responsible transmission utility [61].



As there are currently no offshore wind farms located in Indian waters, offshore wind does not receive specific treatment in the Grid Codes and technical standards. Whilst early projects may proceed under special, bespoke, arrangements, as the industry continues to develop it is likely that code modifications will be necessary to address the growing impact of this generating technology on the power system.

7.2.4.2 Offshore Grid Code Compliance

Typically, compliance with the technical requirements of a grid code is measured at the point of connection to the Inter or Intra-State transmission system. However, depending upon the ownership and grid build-out model (as discussed in Section 5.5) it is possible that this point of connection could be offshore, if the CTU or STU extends the power system out to the offshore generator.

Should this be the case, the rationale for imposing full Grid Code compliance upon a generator at the offshore connection point becomes less clear. As the radial transmission line is generally a sole-use asset, with no demand connected, the impact of non-compliance with certain Grid Code requirements is minimal. Furthermore, the benefit of compliance with certain requirements (e.g. reactive power control) is greatest closer to the existing system and demand, and the costs of installing mitigation offshore is correspondingly more expensive than onshore.

Therefore, should the generator/transmission utility boundary be offshore, consideration may need to be given to identifying a separate interface point for measuring Grid Code compliance, and/or relaxing the compliance requirements at the offshore connection point to reflect the reduced benefit and increased costs of meeting these requirements.

An example separation, along with a potential split of Grid Code requirements, is shown below. This is effectively the UK approach, which was encoded via the sweeping modifications to enable the chosen offshore transmission model [60].

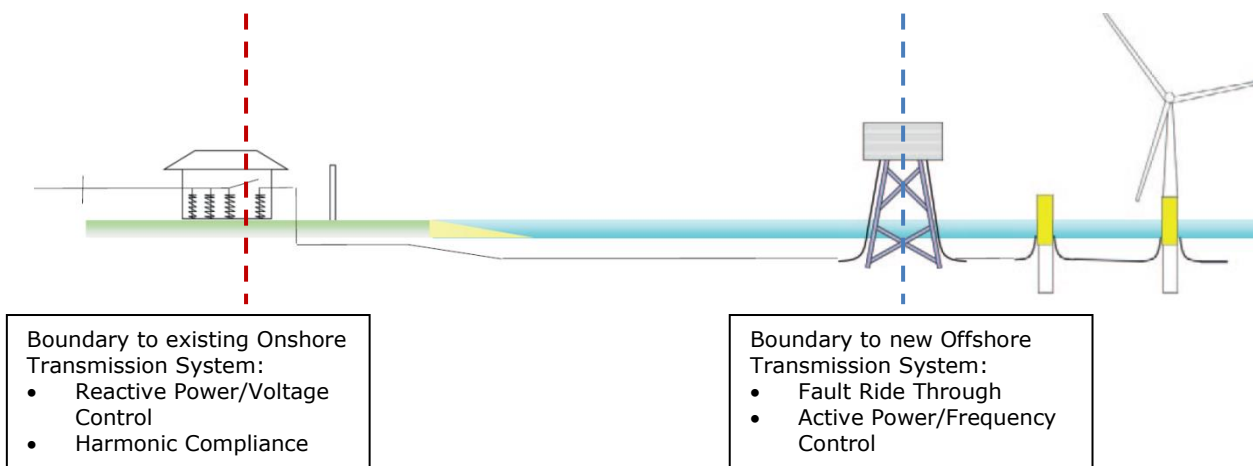

Figure 54: Example separation of compliance requirements for offshore generators [31]

The UK model is somewhat different to the model in the German North Sea, where Tennet is the Transmission Utility responsible for providing Grid Connections to offshore generators. Under this regime a separate Grid Code document applies to offshore generation, and the connection point and compliance point are both located offshore necessitating reactive power and harmonic compliance are met offshore [61]. In the case of Tennet’s system, the rationale for this approach derives partly from the topology of their offshore grid; i.e. clustered, with multiple parties sharing common assets offshore who may be adversely impacted by one party’s non-compliance.



In the case that the ownership boundary between generator and Transmission Utility is located onshore (i.e. generator owns the sole use, offshore transmission line), the situation is somewhat simpler and it is expected that Grid Code compliance will also be measured at the onshore boundary.

In conclusion, the application of Grid Code requirements offshore may follow several models and should consider:

- The offshore transmission ownership model
- The offshore grid topology
- The relative effectiveness of meeting the requirements on-and-offshore
- The relative cost of meeting the requirements on-and-offshore

7.3 System Planning/Reliability Standards

CEA is responsible for preparation of prospective generation and transmission plans and coordinating the activities of planning agencies. The CTU is responsible for development of ISTS and the STU is responsible for Intra-STS. Since ISTS and Intra-STS are interconnected and together constitute the electric grid, it is imperative to have a uniform approach for developing a reliable transmission system.

The planning criteria is meant for ISTS down to 132 kV and Intra-STS down to 66 kV level, including the dedicated transmission lines. CEA issued a manual on transmission planning criteria in 1994 and subsequently updated it in 2013 with renewable integration in perspective [62]. The current criteria apply to only onshore wind and solar generators. It is imperative that this planning criteria shall cover future offshore wind generation connections.

The first and obvious choice is to examine if the current criteria can be effectively applied to offshore wind connections. Proper attention shall be paid to certain factors that distinguish offshore wind connections from onshore wind/ solar connections, such as:

- Geography of the offshore connections and ownership of offshore platform, offshore transmission system, onshore transmission system which forms part of offshore wind project, interface point of offshore wind project to the onshore transmission system etc.
- Predominantly radial nature of offshore transmission systems which could impact overall reliability of power transfer, value of energy curtailed, possible implications on operating reserves in system etc.
- Available offshore wind technologies in the market and their implication on key planning and security criteria and parameters
- Distance of offshore substation from the shore.

Similar considerations have been taken in other mature offshore wind markets like UK.

7.3.1 Case Study: Inclusion of Offshore Wind Generation in SQSS

The Great Britain Security and Quality of Supply Standard (GB SQSS) provides a coordinated set of criteria and methodologies that electricity transmission licensees are required to apply when planning and developing (and in the case of the system operator, operating) the onshore transmission systems [63]. The criteria in the current GB SQSS are underpinned by cost benefit analysis. Compliance with the GB SQSS is a requirement of the current electricity transmission licence. Available evidence shows that installation of transmission assets offshore is substantially more expensive than onshore. Hence Ofgem,



the regulator for gas and electricity markets in UK, decided to conduct additional cost-benefit analysis to assess the level of security that are justifiable for offshore electricity transmission networks [64].

The following criteria has been set out for the cost-benefit analysis:

- proposed connection designs for offshore wind farm developments currently in the planning process;
- default scope of an offshore electricity transmission network in terms of the interface points with the offshore generator and the onshore network; and
- likely voltage performance of and the need to specify voltage limits for offshore electricity transmission networks.

Table 22 summarises the key findings and their implication in SQSS.

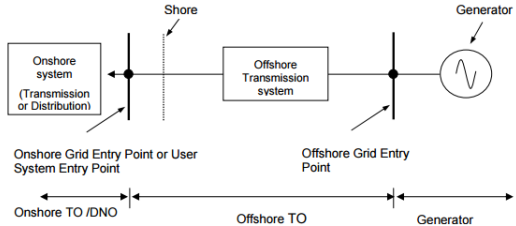
SI No	Key findings	Implication in SQSS
1	<p>Clarity on designation of offshore transmission system</p> 	<p>Offshore transmission system is considered as a separate chapter and SQSS clarifies the possible ambiguity in terms of ownership and designation of different parts such as offshore platform, offshore transmission system, onshore transmission system which forms part of offshore wind project, interface point of offshore wind project to the onshore transmission system etc.</p>
2	<p>The cost-benefit analysis proved that the current SQSS planning and operational standards are not appropriate for offshore transmission system development due to relative cost and available ratings of the offshore transmission assets. Hence the security assessment of offshore transmission system is carried out in three separate sections: offshore platform, offshore network capacity, and voltage requirements.</p>	<p>Offshore platform (AC transformers, AC platform interconnection circuits, and DC converters)</p> <ul style="list-style-type: none"> - Criteria on platform capacity for single and multiple wind farm connections - Criteria on minimum power export capacity during outages (planned and unplanned) <p>Offshore network capacity (AC/DC cables)</p> <ul style="list-style-type: none"> - Criteria on normal transfer capacity for single and multiple wind farm connections - Criteria on minimum power export capacity during outages (planned and unplanned) <p>Voltage requirements</p> <ul style="list-style-type: none"> - Voltage requirements for offshore network includes the interface with the onshore network, particularly with



		<p>respect to reactive power transfer. All applicable onshore requirements shall be followed at the interface.</p> <ul style="list-style-type: none"> - Criteria on voltage step limits at the interface with onshore network. <p>The main recommendations include 2x transformers on an offshore substation (min 50% rated) and N-0 redundancy on offshore cables.</p>
3	Provision for variations to generator connection design	The transmission licensee shall meet the generator's request for security above or below the minimum standard provided there is no adverse impact on any other user.

Table 22: Key findings and implications of including offshore generation in SQSS

7.3.2 Recommendations for CEA's Transmission Planning Criteria

FOWIND has the following recommendations for including offshore wind generation in CEA's transmission planning criteria:

- Incorporate various offshore wind transmission components into CEA and clarify the ownership and designation of different parts such as offshore platform, offshore transmission system, onshore transmission system which forms part of offshore wind project, interface point of offshore wind project to the onshore transmission system etc.
- Review the voltage and reliability criteria (N-0, N-1, and N-1-1) for steady-state specifically for offshore wind generation system, considering the parameters such as reliability of typical offshore transmission system, value of energy curtailed, possible operational requirements arising from planned or unplanned outages etc. It is not recommended to introduce anything other than N-1 security requirements on the offshore system.
- Review the applicability of existing transient-state criteria with respect to offshore wind generation system and clarify the compliance nodes for different requirements.
- The time horizons for transmission planning shall consider the expected gestation time offshore wind generation in Indian context.
- Review all the terminologies in the document and incorporate offshore wind generation system specific terminologies and definitions including AC and DC offshore platform, submarine cable (AC and DC), onshore transmission system, and interface points.

7.4 Key Issues for Offshore Wind in India

The issues from this section relating to development and integration of offshore wind projects to Tamil Nadu's power system are given below:

- The Grid Application process for an offshore wind project should be clarified, particularly with respect to data provision requirements and treatment of an offshore connection point. The schedule for processing such applications should be revisited due to the numerous potential connection permutations possible for a wind farm located some way offshore.



- It should be recognised that it is highly likely that offshore wind projects will need to revise their quantum of power to be installed as the development process progresses and new surveys etc. refine the zonal capacity. The application change process should be suitably flexible to accommodate this without putting disproportionate risk on the offshore wind farm.
- Once LTA is obtained, the lead time for constructing the necessary transmission reinforcements is likely to be on the overall project’s critical path; any delays could be significant risks.
- Having compared the Indian Grid Code and technical requirements thereof to those of more mature offshore wind markets in the UK and Germany, it does not appear to place onerous requirements that offshore wind generation projects would be unable to meet. That said, the introduction of more stringent frequency response requirements [58], particularly rapid upwards regulation services, will be challenging for any RES and the scale of offshore wind projects is likely to make the cost of provision of such large storage systems (if needed to comply with this requirement) prohibitive.
- Offshore wind generation is not specifically addressed in the Grid Codes at present, and this may cause some confusion about the applicability of certain requirements (particularly at which point in the system they apply). It is recommended to initiate a grid code review in the context of offshore wind, comparing it with mature offshore wind markets, to identify if any specific measures, caveats or clarifications should be introduced.
- The current transmission planning criteria do not address specific criteria for offshore wind generation planning. It is recommended to review the planning requirements with respect to offshore wind generation and clarify the aspects like ownership of offshore and onshore transmission structures and interfaces, voltage and reliability criteria, applicability of existing transient-state criteria etc.

7.5 Recommendations

Key recommendations drawn from this chapter are summarised below:

Sub-Objective: Ensure technical and regulatory codes are suitable for offshore wind projects		
Barrier	Mitigation	Key Stakeholder
The connection process does not specifically address offshore wind projects.	Publish guidance on connection application process for the first offshore windfarms.	CTU, STUs, CERC, SERCs
Grid codes do not specifically address specific characteristics of offshore wind and its transmission connection	<p>Future code modifications should be reviewed considering the specific characteristics and quantum of power from offshore wind farms.</p> <p>Review the need for a separate grid code or modifications specifically for offshore wind projects.</p> <p>Clarify on the compliance boundary of OWF under</p>	CEA, CTU, STUs, CERC, SERCs



	individual grid code requirements	
Planning standards do not address reliability standards for offshore connections.	Clarify on the applicability of present planning standards and consider the need for an offshore specific set of planning standards.	CEA, CTU, STUs

Table 23: Key recommendations for the technical codes



8 SUMMARY OF RECOMMENDATIONS

At the end of each preceding chapter, this report outlines several recommendations which will facilitate the grid integration of offshore wind into the Indian power system. A consolidated list of these recommendations is shown below.

Chapter 4: Onshore Grid Development		
Sub-Objective: Prepare the onshore grid for the integration of offshore wind		
Barrier	Mitigation	Key Stakeholders
Offshore wind not included in current grid planning scenarios	Formulate state and national targets for offshore wind Include offshore wind development scenarios in long term planning	MNRE, MoP CEA, CTU and STUs
Delayed delivery of necessary onshore grid reinforcements causing power export constraints	Prioritise anticipatory investment in grid expansion (e.g. Green Energy Corridors)	CTU and STUs
Difficulty in obtaining right of way for onshore transmission infrastructures	Streamline national and state planning and permitting processes for critical infrastructure projects	MoP, SEB, CTU and STUs
Chapter 5: Offshore Grid Development		
Sub-Objective: Facilitate offshore grid development for the integration of offshore wind		
Barrier	Mitigation	Key Stakeholders
No policy exists for delivery and ownership of offshore transmission systems.	Select either generator built or TSO built model for ownership of the first offshore wind projects Initiate a Central Working Group to frame an enduring national offshore transmission policy	CEA, CTU, STUs CEA, MoP, MNRE,
No framework exists for offshore transmission network planning.	Initiate a Working Group to evaluate the optimal transmission topology and system planning regime for Gujarat and Tamil Nadu.	CEA, CTU, STUs
There is limited experience in India for the planning, design and construction of offshore transmission systems.	International consultants may fill the gap in the short term. A longer term roadmap for development of local competencies should be devised.	CTU, STUs



Chapter 6: System Operation

Sub-Objective: Ensure stable system operation with increasing penetration of offshore wind and other RES

Barrier	Mitigation	Key Stakeholder
Incomplete/delayed enforcement of national action plan for facilitating large scale renewable integration	Rigorous follow-up and timely enforcement of identified mitigation measures	NLDCs, RLDC, CTU
Uncertainty around the absolute level of grid curtailment at present and expected in the near future	Measure, report and set targets on curtailment levels	CERC, RLDCs, SERCs, SLDCs
Limited experience in system operation with increased penetration of RES	Review the international practices and implement knowledge exchange/ capacity building programs to fulfil the gaps in the short term Long term roadmap for development of local competencies	NLDC, RLDCs, SLDCs

Chapter 7: Technical and Regulatory Codes

Sub-Objective: Ensure technical and regulatory codes are suitable for offshore wind projects

Barrier	Mitigation	Key Stakeholder
The connection process does not specifically address offshore wind projects.	Publish guidance on connection application process for the first offshore windfarms.	CTU, STUs, CERC, SERCs
Grid codes do not specifically address specific characteristics of offshore wind and its transmission connection	Future code modifications should be reviewed in light of the specific characteristics and quantum of power from offshore wind farms. Review the need for a separate grid code or modifications specifically for offshore wind projects. Clarify on the compliance boundary of OWF under individual grid code requirements	CEA, CTU, STUs, CERC, SERCs



<p>Planning standards do not address reliability standards for offshore connections.</p>	<p>Clarify on the applicability of present planning standards and consider the need for an offshore specific set of planning standards.</p>	<p>CEA, CTU, STUs</p>
--	---	-----------------------



9 CONCLUSIONS

The MNRE has set ambitious targets for RES in India of 175GW by 2022. At present this is expected to comprise solar PV, onshore wind, small hydro and biomass with no specific targets yet for offshore wind. Previous FOWIND Pre-feasibility reports identified significant offshore wind potential in the states of Gujarat and Tamil Nadu [25], [28] and thanks to reducing costs, high capacity factors and complementary production cycles to solar, offshore wind has the potential to contribute appreciably to current and future RES policy goals.

One of the identified challenges to build-out of offshore wind in Gujarat and Tamil Nadu is the integration of electricity generated by offshore wind farms. This report has addressed some of these challenges in the context of:

- Onshore Grid Development;
- Offshore Grid Development;
- System Operation; and
- Technical and Regulatory Codes.

In addressing these subjects, 12 practical recommendations have been formulated in the preceding section. These can be viewed within four overarching 'themes' which should be addressed by government and industry stakeholders if a successful offshore wind industry is to be built.

9.1 Delivery of Existing RES Action Plans

Whilst there are challenges associated with the increased penetration of RES into the Indian power system, some experienced on a National level, some on a state level, a number of major initiatives are underway. Notable amongst these are the Green Energy Corridors (investing in high capacity new lines to facilitate RES power evacuation) and the National Action Plan for Large Scale Integration of Renewable Energy [46] addressing various operational issues of large scale RES integration. These initiatives will certainly facilitate the grid integration of offshore wind, reduce delivery and curtailment risks, and should be reviewed in light of any specific policy targets for build-out of offshore wind projects. However, a failure to achieve these existing roadmap goals will likely have a detrimental impact upon the development of a larger, successful offshore wind industry in India.

9.2 Offshore Wind Policy and Code Development

Aside from existing RES initiatives described and due to the early stage of the industry, offshore wind specific policies and code frameworks are not presently developed in India; namely:

- Lack of the lack of clear offshore wind build-out targets to enable state and national infrastructure planning for offshore wind.
- The lack of a framework for delivery and ownership of offshore grid systems to connect offshore wind.
- A lack of specific treatment of offshore wind in technical and regulatory codes and processes.

To ensure that these are not barriers to offshore wind development, guidance on the treatment of initial, pilot, offshore wind projects would be beneficial as well as a wider policy and code review in light of future industry growth scenarios.



9.3 Grid Development Planning

Grid integration studies have been performed on behalf of the FOWIND consortium by both GETCO and TANGEDCO to identify whether, against the current background, it will be possible to evacuate power from a 500MW offshore wind farm in the respective states. In both cases, it appears that at least an initial project of 500MW could be connected with minimum system reinforcements (subject to validation through more detailed studies).

However, should larger volumes of offshore wind be planned further strategic Grid development studies will be necessary to identify possible transmission bottlenecks to wider integration of offshore wind beyond these initial projects. Furthermore, the general approach to grid development and planning would benefit from review in order to ensure that appropriate offshore grid topologies are developed which reflect the needs of both offshore generators and the wider onshore grid, and that the system planning function (either centralised or de-centralised) is consistent with overall policy goals and ensures a secure, stable and economic evacuation of offshore wind power into the grid.

9.4 Competence and Capability Development

Whilst offshore grid systems are similar in principle to onshore grid systems there are subtle differences in terms of the nature of components employed and their application in an offshore environment. Specific amongst these differences are the application of large volumes of submarine HVAC cabling, potential use of offshore HVDC systems and relative component cost and risk profiles which influence overall system design. Lessons have been learnt in offshore grid development internationally and it will be important that these lessons are applied in an Indian context to de-risk delivery of critical offshore infrastructure. International consultants with experience from mature markets may fill the gap in the short term, but over the long term the development of strong local offshore design, planning and construction capabilities will be beneficial.

Furthermore, existing problems facing grid operation are likely to be exacerbated with increased penetration of offshore wind and therefore implementing a competence development roadmap for system operations personnel, with input from international TSOs with experience in managing high RES penetration, would benefit the industry as a whole and facilitate build-out of offshore wind specifically.



10 REFERENCES

- [1] Central Electricity Authority, "Power sector monthly report December 2016," New Delhi, 2016.
- [2] The World Bank, "Electric power consumption (kWh per capita)," *World Development Indicators*, 2016. .
- [3] Central Electricity Authority, "Draft National Electricity Plan, Volume 1 (Generation)," New Delhi, Dec. 2016.
- [4] International Energy Agency, "India Energy Outlook 2015," Paris, 2015.
- [5] Central Electricity Authority, "Power Sector Monthly Executive Summary - January 2017," Feb. 2017.
- [6] S. D. Ghude *et al.*, "Premature mortality in India due to PM2.5 and ozone exposure," *Geophys. Res. Lett.*, vol. 43, no. 9, pp. 4650–4658, May 2016.
- [7] R. Gupta, E. Somanathan, and S. Dey, "Global warming and local air pollution have reduced wheat yields in India," *Clim. Change*, vol. 140, no. 3–4, pp. 593–604, Feb. 2017.
- [8] "India's Intended Nationally Determined Contribution," Oct. 2015.
- [9] International Energy Agency, "Energy Technology Perspectives: Scenarios & Strategies to 2050," Paris, 2010.
- [10] IRENA, "The Power to Change: Solar and Wind Cost Reduction Potential to 2025," 2016.
- [11] Central Electricity Regulatory Commission, "Report on Short-term Power Market in India: 2015-16," 2016.
- [12] Global Wind Energy Council, "Global Wind Energy Statistics 2016," Feb. 2017.
- [13] Government of India, "National Offshore Wind Energy Policy." New Delhi, 2015.
- [14] Ministry of New and Renewable Energy, "Resolution: Jawaharlal Nehru National Solar Mission." New Delhi, 2010.
- [15] I. Kundu, "Violent anti-land acquisition agitation erupts in Bengal over power project," *India Today*, 2017. .
- [16] A. Roy, "Land acquisition problems dog solar power plants," *Times of India*, 2014. .
- [17] R. Perez and J. Freedman, "Off-Shore Wind and Grid-Connected PV: High Penetration Peak Shaving for New York City," in *Proceedings of World Renewable Energy Forum*, 2012.
- [18] Ministry of Power, "Annual Report 2015-16," 2016.
- [19] Ministry of New and Renewable Energy, "MNRE Annual Report 2016-17," 2017.
- [20] Central Electricity Authority, "Draft National Electricity Plan, Volume II (Transmission)," Dec. 2016.
- [21] Central Electricity Authority, "Power Transmission Maps of India." Ministry of Power, Jul-2016.
- [22] Power Grid Corporation of India Ltd., "Report on Green Energy Corridors: Transmission Plan for Envisaged Renewable Capacity," Jul. 2012.
- [23] Gujarat Energy Transmission Corporation Limited, "Annual Report 2015-16, State Load Dispatch Centre," 2016.
- [24] National Institute of Wind Energy, "Wind Power Potential at 100m agl." [Online]. Available: http://niwe.res.in/departement_wra_100m_agl.php. [Accessed: 01-Feb-2017].
- [25] FOWIND, "Pre-Feasibility Study for Offshore Wind Farm Development in Gujarat," May 2015.



- [26] Gujarat Energy Transmission Corporation Limited, "Intra-State Transmission Scheme under GEC of Gujarat." 2015.
- [27] Southern Regional Power Committee, "SRPC Grid Map," 2016. [Online]. Available: <http://www.srpc.kar.nic.in/website/GridMap/gridmap.html>. [Accessed: 01-Mar-2017].
- [28] FOWIND, "Pre-Feasibility Study for Offshore Wind Farm Development in Tamil Nadu," May 2015.
- [29] "MHI Vestas unveils 9MW giant," *Renews*, 2017. [Online]. Available: <http://renews.biz/105692/mhi-vestas-unveils-9mw-giant/>. [Accessed: 30-Mar-2017].
- [30] International Electrotechnical Commission, "IEC 61400-27-1 Wind turbines - Part 27-1: Electrical simulation models." Feb-2015.
- [31] The Crown Estate, "Transmission infrastructure associated with connecting offshore generation," Apr. 2013.
- [32] Renewables Advisory Board, "Value breakdown for the offshore wind sector," Feb. 2010.
- [33] National Grid, "Electricity Ten Year Statement," 2016.
- [34] "Prysmian's fourth HVDC subsea cable commissioned in 2015," *Wire and Cable News*, 2015. [Online]. Available: <http://wireandcablenews.crugroup.com/wireandcablenews/news/free/2015/04/4176526/>. [Accessed: 01-Feb-2017].
- [35] Gujarat Electricity Regulatory Commission, "Terms and Conditions of Intra-State Open Access Regulations," 2011.
- [36] 50hertz, "Kriegers Flak – Combined Grid Solution," 2016. [Online]. Available: <http://www.50hertz.com/en/Grid-Extension/Offshore-projects/Projects/Combined-Grid-Solution>. [Accessed: 01-Mar-2017].
- [37] ABB, "XLPE Land Cable Systems User's Guide (Rev 5)," 2010.
- [38] ABB, "XLPE Submarine Cable Systems Attachment to XLPE Land Cable Systems - User's Guide (Rev 5)," 2010.
- [39] L. Meeus, "Offshore grids for renewables: do we need a particular regulatory framework?," 2014/24, 2014.
- [40] C. Brown, R. Poudineh, and B. Foley, "Achieving a Cost-competitive Offshore Wind Power Industry: What is the Most Effective Policy Framework?," 2015.
- [41] ISLES Project, "Examples of Collaboration and Best Practice in Offshore Grid Connectivity to Enable Offshore Renewables," Jun. 2015.
- [42] T. Schittekatte, "UK vs DE: two different songs for transporting energy to shore," 2016. .
- [43] U. Ofgem, "OFTO Tender Round 5 presentation." 2016.
- [44] Cambridge Economic Policy Associates Ltd, "Evaluation of OFTO Tender Round 2 and 3 Benefits," Mar. 2016.
- [45] "India Power Grid Map," 2016. [Online]. Available: <http://www.mapsofindia.com/maps/india/power-grid.html>. [Accessed: 06-Apr-2017].
- [46] Ministry of Power, "Report of the Technical Committee on Large Scale Integration of Renewable Energy, Need for Balancing, Deviation Settlement Mechanism (DSM) and associated issues," Apr. 2016.
- [47] GIZ, "Market Design for an Electricity System with higher share of RE Energy Sources," 2015.
- [48] Government of Gujarat and Ministry of Power, "24x7 Power for All (Gujarat)," Feb. 2016.



- [49] Central Electricity Regulatory Commission, "Order in Petition No. 420/MP/2014." New Delhi, Jan-2016.
- [50] Tamil Nadu Electricity Regulatory Commission, "Order M.P.No.14 of 2012, D.R.P.No.28 of 2012, M.P.No.21 to 23 of 2014 and D.R.P.No.45 of 2014." Jul-2015.
- [51] Central Electricity Regulatory Commission, "Proposed amendment to the Detailed Procedure in view of online submission of Applications." Jun-2015.
- [52] Central Electricity Authority, "Technical Standards for Connectivity to the Grid (Amendment)," 2012.
- [53] Central Electricity Regulatory Commission, "Indian Electricity Grid Code," 2010.
- [54] Tamil Nadu Electricity Regulatory Commission, "Tamil Nadu Electricity Grid Code," 2005.
- [55] International Electrotechnical Commission, "IEC 61400-1 (2005) Wind turbines - Part 1: Design requirements." 2005.
- [56] Central Electricity Authority, "Technical Standards for Connectivity to the Grid," 2007.
- [57] Institute of Electrical and Electronics Engineers, "IEEE Std 519 (2014) IEEE recommended practice and requirements for harmonic control in electric power systems." p. 17, Jun-2014.
- [58] Central Electricity Authority, "Technical Standards for Connectivity to the Grid (Draft 2nd Amendment)," 2016.
- [59] N. Miller, K. Clark, and M. Shao, "Frequency responsive wind plant controls: Impacts on grid performance," in *Power and Energy Society General Meeting, 2011 IEEE*, 2011.
- [60] Department of Energy and Climate Change, "Government response to consultations on offshore electricity transmission Annex 2: Grid Code," 2010.
- [61] TenneT, "Requirements for Offshore Grid Connections in the Grid of TenneT TSO GmbH," Dec. 2012.
- [62] Central Electricity Authority, "Manual on Transmission Planning Criteria," Jan. 2013.
- [63] Office of Gas and Electricity Markets (UK), "National Electricity Transmission System Security and Quality of Supply Standard, Version 2.3," 2016.
- [64] Office of Gas and Electricity Markets (UK), "A security standard for offshore transmission networks - an initial joint DTI/Ofgem consultation," Dec. 2006.



APPENDIX 1 GETCO REPORT



Report
on
System Studies for Feasibility of
Evacuation of 500 MW Power from
Offshore Wind farm,
At Pipavav, District: Bhavnagar,
Gujarat





INDEX

Chapter – 1	PREAMBLE	1
Chapter – 2	METHODOLOGY ADOPTED FOR THE STUDIES	6
Chapter – 3	PROPOSED CONECTIVITY SCHEME	8
Chapter – 4	POWER SYSTEM STUDIES	9
Chapter – 5	SYNOPSIS	15





CHAPTER – 1

PREAMBLE





CHAPTER: 1

1.1 PREAMBLE:

Worldwide, wind energy is accepted as one of the most developed, cost effective and proven renewable energy technologies to meet increasing electricity demands in a sustainable manner. While onshore wind energy technologies have reached a stage of large scale deployment and have become competitive with fossil fuel based electricity generation with supportive policy regimes across the world, exploitation of offshore wind energy is yet to reach a comparable scale. India has achieved significant success in the onshore wind power development with about 27 GW of wind energy capacity already installed and generating power.

Electricity generation from renewable sources of energy is an important element in the Government of India's National Action Plan on Climate Change (NAPCC). The Gujarat Government has launched "Vibrant Gujarat" plan, which has generated a lot of interest in Wind Energy sector. Non-conventional energy sources play a vital role in power sector thereby taking some pressure off conventional energy sources.

With introduction of NAPCC, the Government of India is committed to provide a conducive environment for harnessing offshore wind energy in India. In consonance with the mandate and responsibility, the Government envisions to carry forward, in a systematic manner, the development of offshore wind energy in the country, to overcome the existing barriers and to create technological and implementation capabilities within the country. Ministry of New & Renewable Energy, Government of India has introduced "National Offshore Wind Energy Policy – 2015" as an attempt to replicate the success of onshore wind power development in the offshore wind power development.



The key benefits of offshore wind are:

- The wind resource offshore is generally much greater, thus generating more energy from fewer turbines;
- Most of the world's largest cities are located near a coastline. Offshore wind is suitable for large scale development near the major demand centers, avoiding the need for long transmission lines;
- Building wind farms offshore makes sense in very densely populated coastal regions with high property values, because high property values makes onshore development is expensive sometimes leads to public opposition.

Over 12 GW offshore wind capacity has already been installed around the world with more than 90% capacity in Northern Europe.

Development of Offshore wind farm in India:

India is blessed with coastline of about 7600 Km. Preliminary assessments along the coastline have indicated prospects of development of offshore wind power. Wind resource data collected for the coastline of Rameshwaram & Kanyakumari in Tamil Nadu and Gujarat Coast shows reasonable potential.

1.2 FOWIND Project:

The consortium led by Global Wind Energy Council (GWEC) is implementing the Facilitating Offshore Wind in India (FOWIND) project. The consortium partners are;





- Global Wind Energy Council (GWEC)
- Centre for Study of Science, Technology and Policy (CSTEP)
- DNV GL
- Gujarat Power Corporation Limited (GPCL)
- World Institute of Sustainable Energy (WISE) and
- National Institute of Wind Energy (NIWE)

The consortium was formed in response to a project proposal call under the Indo-European co-operation on Renewable Energy Program and is funded through a grant from European Union. In close consultation with the Ministry of New and Renewable Energy (MNRE) and State governments, this project will facilitate offshore wind power development in India and in turn contribute to India's transition towards use of clean technologies in the power sector.

FOWIND is a four-year project to develop a roadmap for offshore wind development in India, which focuses on the States of Gujarat and Tamil Nadu for identification of potential zones for development through techno-commercial analysis and preliminary resource assessment. It will also establish a platform for structural collaboration and knowledge sharing between stakeholders from European Union and India, on offshore wind technology, policy, regulation, industry and human resource development. FOWIND activities will also help facilitate a platform to stimulate offshore wind related R&D activities in the country. Objectives of FOWIND are:

- Create an enabling environment through resource mapping, policy guidance and capacity building measures to unlock the offshore potential in India
- Undertake techno-commercial studies to showcase the potential of offshore wind projects
- Create strategic partnerships, which enhances access and creates awareness on offshore wind technology



- To assess the infrastructure base and identify improvements required
- To build partnerships at a technical, policy and research level both within India and between India and European companies, research groups and institutions
- Develop an offshore Wind Outlook and development pathway for India up to 2032

1.3 About GETCO:

Gujarat Energy Transmission Corporation Ltd (GETCO) was formed in 1999 and was registered under the Companies Act, 1956 as a part of the power sector reforms process in the state. The Company was promoted by erstwhile Gujarat Electricity Board (GEB) as its wholly owned subsidiary in the context of liberalization and as a part of efforts towards restructuring of the Power Sector. The company commenced commercial operation with effect from 1st April 2005.

Organizational development and institutional strengthening are the other areas into which the management of GETCO is looking into to transform GETCO into a commercially viable vibrant organization. Apart from internal reforms – institutional strengthening and organizational development – GETCO is also gearing up to meet the regulatory challenges, both in terms of operational efficiency and commercial & financial implications of the same.

Further, GETCO was notified as State Transmission Utility (STU) by Government of Gujarat vide Notification No.GHU-04-31-GEB-1104-2946-K Dated 29th May 2004 with the purpose of improving efficiency in the state's electricity transmission activities.



Role of STU:

As per Section 39 of Electricity Act, 2003, functions of STU are –

- To undertake transmission of electricity through intra state transmission system.
- To discharge all functions of planning and coordination relating to intra state transmission system with
- To ensure development of an efficient, coordinated and economical system of intra state transmission lines for smooth flow of electricity from a generating station to the load centers.
- To provide non discriminatory open access to its transmission system for use on payment of transmission charges.

1.4 System study for integration of 500 MW Offshore wind project for 2020 timeframe:

WISE requested GETCO to carry out system studies under 2020 timeframe for integration of 500 MW offshore wind project proposed near Pipavav, Bhavnagar, Gujarat under FOWIND project.

The Load Flow Studies and Short Circuit studies are carried out to check the feasibility and to access the transmission infrastructure required for evacuating 500 MW offshore wind farm generation in the GETCO grid during peak and off-peak load conditions for 2020 timeframe.

System studies are carried considering 500 MW injection from an on-shore pooling station near Pipavav to be established by offshore wind developer. Evacuation of power from offshore WTGs to on-shore pooling station is to be arranged by wind farm developer.



CHAPTER – 2

METHODOLOGY ADOPTED FOR THE STUDIES





CHAPTER : 2

2.1 METHODOLOGY ADOPTED FOR THE STUDIES:

The load flow studies for evacuation of the total wind farm generation of 500 MW under peak load and off-peak load conditions corresponding to 2020 period have been done with following assumptions:

- Planned STU & CTU transmission network up to 2020 time-frame (including 400 KV D/C Amreli – Kasor line, 400 KV Pipavav substation, 220 KV Talaja substation, 220 KV D/C Amreli – Visavadar – Timbdi line, etc. surrounding Pipavav area)
- Anticipated conventional generation capacity addition for 2020 time-frame (including EPGL Phase-II : 2 x 660 MW at Salaya and Shapoorji Pallonji : 2 x 660 MW at Kodinar in Saurashtra area)
- Anticipated RE capacity addition (in-principle approval given by GETCO) : 10000 MW wind (including 800 MW additional wind power planned in the Amreli / Bhavnagar area) out of which around 3933 MW already commissioned + 2500 MW Solar power out of which around 1103 MW already commissioned.
- Maximum 70% RE injection is considered along with 70% ex-bus capacity for conventional power projects located in Saurashtra area (near to technical minimum capacity)
- Average peak load is considered for Gujarat system for 2020 condition i.e. around 19000 MW (including transmission losses + auxiliary consumption).
- Peak and Off-peak demand of Saurashtra area (surrounding Pipavav) is considered as 6500 MW and 4200 MW respectively.
- It is assumed that the generated power from proposed 500 MW offshore wind project will be consumed within Gujarat only.
- These studies are carried out for transmission of power from on-shore pooling station to be established by offshore wind developer.



Study Report



- Transmission of power generated from off-shore WTGs up to on-shore pooling station shall be studied and planned by FOWIND / offshore wind developer.

The short circuit study for determining the maximum three phase symmetrical fault level for 2020 timeframe is carried out.



CHAPTER – 3

PROPOSED CONNECTIVITY SCHEME





CHAPTER: 3

3.1 PROPOSED CONNECTIVITY SCHEME:

Following generation capacity is already granted connectivity at 66 KV / 220 KV voltage class surrounding Pipavav area:

- GPPC, Pipavav CAPP – 2 x 351 MW (already commissioned)
- BECL, Bhavnagar TPS – 2 x 250 MW (units synchronized)
- RE Capacity – 900 MW (already granted)

Looking to the FOWIND project capacity of 500 MW by 2020 timeframe (may be further expanded by additional 500 MW) and also already granted connectivity of around 1400 MW generation capacity at 66 KV / 220 KV network surrounding Pipavav area, connectivity to 500 MW offshore wind project is proposed at 400 KV level.

Detailed connectivity scheme to be established by offshore wind developer is as under:

- 400 KV on-shore pooling station near Pipavav,
- 400 KV D/C on-shore pooling station – Pipavav (proposed GETCO substation) line (approx. 25 RKM),
- 400 KV, 125 MVAR switchable bus reactor / STATCOM at on-shore wind pooling station
- 2 Nos. of 400 KV feeder bays at Pipavav (GETCO) substation

Transmission of power generated from off-shore WTGs up to on-shore pooling station shall be planned by FOWIND / offshore wind developer.

GETCO to establish 400/220 KV Pipavav substation along with 400 KV D/C Pipavav – Amreli D/C line by 2020.



CHAPTER – 4

POWER SYSTEM STUDIES





CHAPTER: 4

4.1 POWER SYSTEM STUDIES:

The maximum and minimum reactive power limits of the wind farm generators are considered as '0 (zero)' MVA_r so that the wind farm generators will neither draw nor inject any reactive power from or to the grid.

To access the transmission requirement for grid integration of 500 MW offshore wind project near Pipavav, a lump wind generator with 500 MW capacity is considered at on-shore pooling station to be established by offshore wind developer. Transmission of power generated from off-shore WTGs up to on-shore pooling station shall be planned by FOWIND / offshore wind developer.

A Load Flow Studies:

Results on the Single Line Diagram (SLD) shall be read as:

- The voltage magnitude of bus is represented by $V(\delta)$, where V is the bus voltage in KV and (δ) is voltage angle in degree.
- The power flow in any element is represented by $P(Q)$ format, where P is the real power and (Q) is the reactive power.
- Power flow P or (Q) away from the bus is shown negative.
- Power flow P or (Q) towards the bus is shown positive.

The different case studies and their analysis are furnished below:



a) Peak Load Condition:

PL-1 Base Case:

This is the base case for feasibility of evacuating 500 MW offshore wind power generation at 400 KV Pipavav substation (GETCO) through 400 KV D/C line with Twin conductor. The line flows are quite normal and within limits. The power flows are shown on the SLD marked as Exhibit-PL-1. Power flow on associated 400 KV lines for before and after integration of 500 MW offshore wind power is tabulated hereunder:

Sr. No.	Name of Transmission Line	Before of 500 MW offshore WTGs	After of 500 MW offshore WTGs
1	400 KV D/C Pipavav – Amreli line	2 x 31 MW	2 x 242 MW
2	400 KV D/C Amreli – Fedra line	2 x 373 MW	2 x 440 MW
3	400 KV S/C Amreli – Chorania line	262 MW	318 MW
4	400 KV D/C Fedra – Kasor line	2 x 495 MW	2 x 539 MW
5	400 KV S/C Chorania – Fedra line	10 MW	-34 MW
6	400 KV S/C Fedra – Kosamba line	360 MW	385 MW
7	400 KV S/C Jetpur – Amreli line	315 MW	265 MW
8	400 KV S/C Chorania – Kasor line	313 MW	326 MW

PL-2 Contingency Case – 1:

In the Base Case, outage of one circuit of the 400 KV D/C Pipavav – Amreli line is considered. The line flows are quite normal and within limits. The power flows are shown on the SLD marked as Exhibit-PL-2.



PL-3 Contingency Case – 2:

In the Base Case, outage of one circuit of the 400 KV D/C Amreli – Fedra line is considered. The line flows are quite normal and within limits. The power flows are shown on the SLD marked as Exhibit-PL-3.

PL-4 Contingency Case – 3:

In the Base Case, outage of one circuit of the 400 KV D/C Fedra – Kasor line is considered. The line flows are quite normal and within limits. The power flows are shown on the SLD marked as Exhibit-PL-4.

PL-5 Contingency Case – 4:

In the Base Case, outage of 400 KV S/C Amreli – Chorania line is considered. The line flows are quite normal and within limits. The power flows are shown on the SLD marked as Exhibit-PL-5.



b) Off-Peak Load Condition:

OPL-1 Base Case:

This is the base case for feasibility of evacuating 500 MW offshore wind power generation at 400 KV Pipavav substation (GETCO) through 400 KV D/C line with Twin conductor. The line flows are quite normal and within limits. The power flows are shown on the SLD marked as Exhibit-OPL-1. Power flow on associated 400 KV lines for before and after integration of 500 MW offshore wind power is tabulated hereunder:

Sr. No.	Name of Transmission Line	Before of 500 MW offshore WTGs	After of 500 MW offshore WTGs
1	400 KV D/C Pipavav – Amreli line	2 x 98 MW	2 x 308 MW
2	400 KV D/C Amreli – Fedra line	2 x 532 MW	2 x 571 MW
3	400 KV S/C Amreli – Chorania line	343 MW	415 MW
4	400 KV D/C Fedra – Kasor line	2 x 757 MW	2 x 764 MW
5	400 KV S/C Fedra – Chorania line	48 MW	45 MW
6	400 KV S/C Fedra – Kosamba line	483 MW	504 MW
7	400 KV S/C Jetpur – Amreli line	408 MW	350 MW
8	400 KV S/C Chorania – Kasor line	431 MW	465 MW

OPL-2 Contingency Case – 1:

In the Base Case, outage of one circuit of the 400 KV D/C Pipavav – Amreli line is considered. The line flows are quite normal and within limits. The power flows are shown on the SLD marked as Exhibit-OPL-2.



OPL-3 Contingency Case – 2:

In the Base Case, outage of one circuit of the 400 KV D/C Amreli – Fedra line is considered. The line flows are quite normal and within limits. The power flows are shown on the SLD marked as Exhibit-OPL-3.

OPL-4 Contingency Case – 3:

In the Base Case, outage of one circuit of the 400 KV D/C Fedra – Kasor line is considered. The line flows are quite normal and within limits. The power flows are shown on the SLD marked as Exhibit-OPL-4. It is observed that 400 KV Fedra – Kasor line (Quad Moose) is getting loaded to the tune of 1089 MW during N-1 contingency of outage of other circuit. However, 400 KV Fedra – Kasor (Quad moose) line being a short distance line with around 100 KM, it is within safe loading limit.

OPL-5 Contingency Case – 4:

In the Base Case, outage of 400 KV S/C Amreli – Chorania line is considered. The line flows are quite normal and within limits. The power flows are shown on the SLD marked as Exhibit-OPL-5.

Especially during off-peak load condition, if the overall system load crashes substantially, the wind farm generation has to be further reduced to such a level that any element of the associated network shall not get overloaded.



B Short Circuit Studies:

The short circuit study for determining the maximum three phase symmetrical fault level for 2020 timeframe is carried out. The fault levels of important and connected substations are furnished below:

Sr. No.	Name of substation	Fault Level	
1	400 KV Pipavav (GETCO)	13.1 KA	9080 MVA
2	400 KV Pipavav (on-shore pooling station)	10.6 KA	7343 MVA
3	400 KV Amreli	30.1 KA	20840 MVA
4	400 KV Fedra	32.9 KA	22763 MVA
5	400 KV Kasor	30.4 KA	21057 MVA
6	400 KV Chorania	45.4 KA	31437 MVA
7	400 KV Jetpur	19.5 KA	13543 MVA
8	400 KV Hadala	29.0 KA	20094 MVA

The above results reveal that the fault level of associated substations are within the limits.



CHAPTER – 5

SYNOPSIS





CHAPTER : 5

1 SYNOPSIS:

From the analysis of the Base Case, the Contingency Case studies and the Short Circuit Studies, the observations are indicated as below:

1. 500 MW power generated from offshore WTGs can be safely evacuated at 400 KV Pipavav (GETCO) substation under peak load & off-peak load conditions with the following transmission system to be established by offshore wind developer:
 - 400 KV on-shore pooling station near Pipavav,
 - 400 KV D/C on-shore pooling station – Pipavav (proposed GETCO substation) line (approx. 25 RKM),
 - 400 KV, 125 MVAR switchable bus reactor / STATCOM at on-shore wind pooling station
 - 2 Nos. of 400 KV feeder bays at Pipavav (GETCO) substation
2. The short circuit studies reveal that the fault level of associated substations are within the limits.
3. It is assumed that the generated power from proposed 500 MW offshore wind project will be consumed within Gujarat only.
4. As drawal points are not known today, network adequacy at drawal points within GETCO network, will be accessed through separate studies after availability of drawal points by FOWIND / offshore wind developer.
5. These studies are carried out for transmission of power from on-shore pooling station to be established by offshore wind developer.



6. Transmission of power generated from off-shore WTGs up to on-shore pooling station shall be studied and planned by FOWIND.
7. FOWIND has to ensure that reactive power requirement of WTGs, on-shore pooling station as well as subsea power cable (for transmission from off-shore platforms to on-shore pooling station) shall be compensated locally and shall not impact the grid.
8. Also, FOWIND have to submit a detailed report to comply with various technical requirements for grid connection of Renewable Energy sources, as per The Central Electricity Authority (Technical Standards for Connectivity to the Grid) Amendment Regulations, 2013 and Grid Code.
9. Whenever any contingency of the evacuation line and / or the associated transmission network occurs, wind generation have to be restricted or stopped to avoid overloading of any element of the associated transmission network.
10. Especially in off-peak load condition, if the overall system load crashes substantially, the wind farm generation has to be reduced to such a level that any element of the associated transmission network shall not get overloaded.
11. This study is purely an indicative study considering all the generation capacity addition and the transmission network corresponding to the timeframe of 2020 and hence, this shall not be considered as an connectivity approval. This study report does not warrant any permission to the said project. Also, due care shall be taken that this report is not to be used for any commercial and / or legal purposes.



APPENDIX 2 TANGEDCO REPORT

: TANGEDCO :

From
Er.M.Balasubramanian, B.E., F.I.E.,
Chief Engineer,
Non-Conventional Energy Sources,
TANGEDCO,
144,Anna Salai,
Chennai 600 002.

To
M/s.FOWIND PROJECT MANAGEMENT
UNIT,
C/o WISE,
Plot No.44,Hindustan Estates,
Road No.2, Kalyani Nagar,
Pune – 411 006.

Lr.No.CE/NCES/EE/WPP/AEE3/F. FOWIND/D. 954 /16, dt: 17.06.2016

Sir,

Sub: TANGEDCO - NCES – Indo European Co-operation on
Renewable Energy Program - Supported by MNRE, GoI - Road
map for Offshore wind development in India, by FOWIND -
grid study report – Communicated – Regarding.

Ref: 1. Your letter dt.30.12.2015.
2. Energy Department Lr.No.1585/E1/2016-1,dt.16.02.2016.4.
3. Lr.No.CE/NCES/EE/WPP/AEE3/F. FOWIND/D.308/16,
dt:18.03.2016.
4. Your e-mail letter dated 10.06.2016.

Based on the request of M/s.FOWIND PROJECT MANAGEMENT
UNIT and payment of necessary fees, TANGEDCO had carried out grid study
towards developing a road map for development of offshore wind power in the
state of Tamil Nadu, under the Indo European Co-operation on Renewable Energy
Program supported by MNRE, GoI .

The grid study /Load flow study report along with the required details is
enclosed vide Annexure, for further action.

Yours faithfully,

CHIEF ENGINEER/NCES

Encl: Annexure.

5/3

G:\offshore FOWIND\letter.docx



Annexure

Load flow study result of the grid study towards developing a road map for development of offshore wind power in the state of Tamil Nadu, under the Indo European Co-operation on Renewable Energy Program supported by MNRE, GoI in coordination with FOWIND.

Discussions were held during the presentation on Offshore Wind Energy development among NCES, Transmission & Planning wings on 29-2-16 and the following points are noted:

- It has been programmed to develop 500 MW in 2020 , 800 MW in 2025 , further 2500 MW in the time frame of 2032. The locations selected for this purpose are stated as Manapad, Punnakayal & Tuticorin ports.
- CE/Transmission suggested connectivity at 400 kV level for the offshore wind generation pooling end to the proposed Samugarengapuram SS since it seems to be the proximate location.

The offshore wind energy generation has been considered for the period of 2020-21. The details of study analysis are given below:

Base case: Network condition for the year 2019-20

Case 1 : Base case + proposed 400 kV Samugarengapuram SS with proposed WEG 178 MW + associated 230 kV connectivity from existing 230 kV SR Pudur SS & proposed 230 kV Muppandal SS (Connected with WEG connected SSs -270 MW)

Case 2: Case 1 for the year condition 2020-21 + Suggested proposal of Kamudhi-Thappagundu 400 kV DC line.

Case 3 : Case 2 without the proposed Kamudhi-Thappagundu 400 kV DC line +2021-22 year condition + Virudhunagar 765 kV SS+Uppur (2x800 MW) connected to Virudhunagar SS + 400 kV Kayathar SSs connected to Virudhunagar SS by 400 kV DC line+ Kamudhi & Thappagundu 400 kV SSs connected to Virudhunagar SS by 400 kV DC line instead of the already proposed direct Kamudhi-Thappagundu link line.



230 kV connectivity

- i) 230 kV DC line from the existing TANTRANSCO SR pudur 230 kV SS
- ii) 230 kV DC line from the proposed TANTRANSCO Muppandal 230 kV SS
- iii) 230 kV connectivity from the proposed wind farm substations at 230 kV level proposed by wind energy promoters.

110 kV connectivity from the existing TANTRANSCO wind farm substations

- i) Kottaikarungulam SS
- ii) Kudangulam SS
- iii) Thandayarkulam SS
- iv) Vadakankulam SS
- v) Navaladi SS
- vi) 110 kV connectivity from the existing Samugarengapuram 10(1) SS.

230/110 kV Muppandal SS

- Establishment of 230/110 kV Muppandal SS with auto transformer capacity of 3x100 MVA and 230 kV connectivity by 230 kV DC line to Samugarengapuram 400 kV SS.
- 110 kV connectivity from the following existing 110 kV TANTRANSCO SSs:
 - Muppandal
 - Aralvaimozhi
 - Perungudi
 - Kannanallur
 - Pazhavor

Offshore wind energy

The proposed generation of 500 MW of Offshore wind energy under MNRE program of GoI, can be considered for connectivity at the proposed Samugarengapuram 400 kV SS in 400 kV level.

The said proposals comes under Green Energy corridor, funded by MNRE-NCEF grant and KfW loan.



Phase II,

Total award Cost - Rs.1596 Crores

- 1) Establishment of Kanarpatti 400/ 230/ 110 KV SS and its allied transmission lines.

The works towards establishment of Kanarpatti 400/230 KV-110 KV SS has been awarded on 11.03.2014 and the works are under progress, expected to be completed by July 2016.

- 2) Establishment of 400/110 KV SS at Thappakundu area and its allied transmission lines.
- 3) Establishment of 400/230-110 KV SS at Anikadavu area and its allied transmission lines.
- 4) Establishment of 400/230-110 KV SS at Rasipalayam area and its allied transmission lines.

394 Kms of 400 KV DC Line connecting Thappagundu- Anikadavu-Rasipalayam – Palavadi and Kanarpatty with associated transmission lines for a total value Rs.1596 crores.

Status - The work towards establishment of Thappakundu, Anikadavu and Rasipalayam 400/230 KV-110 KV SS have been awarded and the works are under progress. Entire corridor works are expected to be completed during 2016-17.

Phase III, Total award Cost - Rs.1593 Crores

One 400 KV SS at Thennampatti with associated 400 KV Line, 200 KMs of 400 KV DC Line connecting Rasipalayam- Palavadi and Augmentation of Transformer capacity at 6 Nos. 230 KV SSs and strengthening of 230 KV Transmission lines connecting various sub stations is taken up under NCEF Grant and KfW Funding.

Status - LOA issued on 25.01.2016, works under progress.

Solar Power Evacuation:

For evacuation of solar power 648 MW Kamudhi area with one 400 kV sub-station Kamudhi with associated transmission lines has been awarded for a value of Rs.520 Crores.



PROJECT PARTNERS



Global Wind Energy Council (Brussels, Belgium) is the international trade association for the wind power industry. The members of GWEC represent over 1,500 companies, organisations and institutions in more than 70 countries.
www.gwec.net



Center for Study of Science, Technology and Policy (Bangalore, India) is one of the largest think tanks in South Asia; its vision is to enrich the nation with technology-enabled policy options for equitable growth.
www.cstep.in



DNV GL (Arnhem, the Netherlands) is the world's largest provider of independent renewable energy advice. The recognised authority in onshore wind energy, DNV GL is also at the forefront of the offshore wind, wave, tidal and solar sectors.
www.dnvgl.com



Gujarat Power Corporation Limited (Gandhinagar, India) has been playing the role of developer and catalyser in the energy sector in the state of Gujarat. GPCL is increasing its involvement in power projects in the renewables sector, as the State of Gujarat is concerned about the issues of pollution and global warming.
www.gpclindia.com



World Institute of Sustainable Energy (Pune, India) is a not-for-profit institute committed to the cause of promoting sustainable energy and sustainable development, with specific emphasis on issues related to renewable energy, energy security, and climate change.
www.wisein.org



KNOWLEDGE PARTNER



National Institute of Wind Energy (NIWE) will support FOWIND efforts towards offshore wind feasibility assessments for potential offshore wind project development in the states of Gujarat & Tamil Nadu - with a special focus on wind resource validation. NIWE is an autonomous R&D institution under the Ministry of New and Renewable Energy, Government of India, established to serve as a technical focal point for orderly development of Wind Power deployment in India.

www.niwe.res.in

INDUSTRY PARTNER



ReNew Power Ventures Private Ltd. join as an industry partner. ReNew Power is a leading clean energy IPP with more than 3 GW of commissioned and under-construction clean energy assets, and a pipeline of close to 1.8 GW wind, solar and distributed solar projects in India.

www.renewpower.in



The **European Union (EU)** is a unique economic and political partnership between 28 European countries. In 1957, the signature of the Treaties of Rome marked the will of the six founding countries to create a common economic space. Since then, first the Community and then the European Union has continued to enlarge and welcome new countries as members. The Union has developed into a huge single market with the euro as its common currency.

What began as a purely economic union has evolved into an organisation spanning all areas, from development aid to environmental policy. Thanks to the abolition of border controls between EU countries, it is now possible for people to travel freely within most of the EU. It has also become much easier to live and work in another EU country.

The five main institutions of the European Union are the European Parliament, the Council of Ministers, the European Commission, the Court of Justice and the Court of Auditors. The European Union is a major player in international cooperation and development aid. It is also the world's largest humanitarian aid donor. The primary aim of the EU's own development policy, agreed in November 2000, is the eradication of poverty.

<http://europa.eu/>

DISCLAIMER

This report is provided for illustrative purposes only without any representations, warranties or undertakings from GWEC, DNV GL, WISE, CSTEP or the European Union as to the content or any part of this report and the data contained therein, including without limitation in respect of quality, accuracy, completeness, or reliability. The information contained in the report does not represent endorsement by GWEC, DNV GL, WISE, CSTEP or the European Union of any particular project, product or service provider.

By accessing the report either in a hard copy or electronically, users accept that neither GWEC, DNV GL, WISE, CSTEP nor the Authors are responsible for any kind of loss or damage resulting from the use of the information contained in the report or for any reliance placed thereon and the users further acknowledge that the content of the report and data therein are subject to change.

Copyright ©FOWIND 2017

Unless otherwise indicated, material in this publication may be used freely, shared or reprinted, but full acknowledgement is requested. This publication should be cited as FOWIND (2017), Grid Integration Study.

ACKNOWLEDGEMENTS

DNV GL co-authors listed alphabetically: Gareth Parker, Rohit Vivek Gadre, Sumith Madampath Sreechithra
Reviewed by: Steve Sawyer (GWEC), Shruti Shukla (GWEC), Alok Kumar (DNV GL), Ruben Menezes (DNV GL), Lyndon Greedy (DNV GL)
Graphic design: Chris Vleeming (DNV GL)

CONTACT

For further information, please contact FOWIND Secretariat at info@fowind.in
This report is available for download from www.fowind.in and the websites of the FOWIND project partners.

