



सत्यमेव जयते

भारत सरकार

Government of India

विद्युत मंत्रालय

Ministry of Power

केंद्रीय विद्युत प्राधिकरण

Central Electricity Authority

विद्युत प्रणाली योजना एवं मूल्यांकन प्रभाग-II

Power System Planning &amp; Appraisal Division-II

सेवा में / To,

विद्युत क्षेत्र में सभी हितधारक /

All Stakeholders in Power Sector

विषय: केंद्रीय विद्युत प्राधिकरण (ट्रांसमिशन प्लानिंग क्रिटेरिया पर मैनुअल), 2023 संशोधन-I के साथ।

Subject: Central Electricity Authority (Manual on Transmission Planning Criteria), 2023 including Amendment -I.

महोदया (Madam)/ महोदय (Sir),

केंद्रीय विद्युत प्राधिकरण (सीईए) ने मैनुअल ऑन ट्रांसमिशन प्लानिंग क्रिटेरिया, 2023 जारी किया था। यह मैनुअल 1 अप्रैल, 2023 से प्रभावी है। योजना प्रक्रिया को कवर करने के लिए, मैनुअल में एक नया अध्याय (अध्याय-7) जोड़ा गया है। इसके अलावा, कुछ कंडक्टरों के मापदंडों को अपडेट किया गया है। संशोधन-I सहित मैनुअल इस पत्र के साथ संलग्न है और सीईए की वेबसाइट (www.cea.nic.in) पर भी उपलब्ध है।

The Central Electricity Authority (CEA) had issued the Manual on Transmission Planning Criteria, 2023. The Manual is in effect from 1<sup>st</sup> April, 2023. In order to cover the planning procedure, a new chapter (Chapter-7) has been added to the Manual. Further, parameters of certain conductors has been updated. The Manual including Amendment-I is enclosed herewith and also available on website of CEA (www.cea.nic.in).

भवदीय/Yours faithfully,

Signed by Bhagwan Sahay

Bairwa

Date: 08-01-2025 12:03:47

मुख्य अभियंता (प्रभारी)/Chief Engineer (I/C)





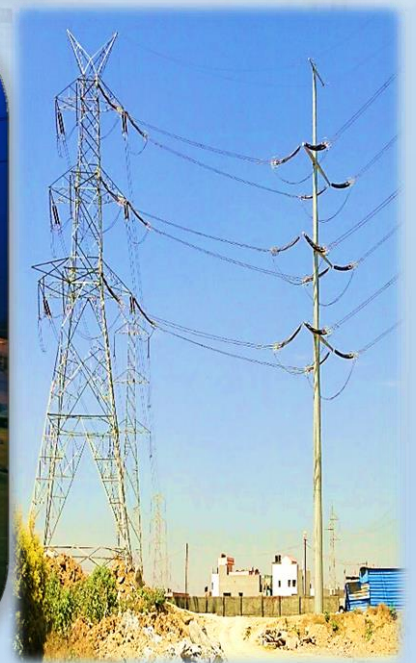
सत्यमेव जयते



# Manual on Transmission Planning Criteria

*(with Amendment-I)*

2025



CENTRAL ELECTRICITY AUTHORITY  
NEW DELHI





# Manual on Transmission Planning Criteria

*(With Amendment-I)*

*January, 2025*

**CENTRAL ELECTRICITY AUTHORITY**



## CONTENTS

DEFINITIONS.....	1
ABBREVIATIONS.....	2
Chapter 1 INTRODUCTION .....	4
Chapter 2 PLANNING PHILOSOPHY .....	7
Chapter 3 TRANSMISSION PLANNING.....	10
Chapter 4 CRITERIA FOR CONTINGENCY .....	23
Chapter 5 SUBSTATION CRITERIA .....	28
Chapter 6 ADDITIONAL CRITERIA .....	33
Chapter 7 PROCEDURE FOR PLANNING OF ELECTRIC POWER TRANSMISSION SYSTEM.....	37
Annexure- I .....	47
Annexure- II.....	61
Annexure- III.....	73

## DEFINITIONS

- 1. Peak Load:** It is the simultaneous maximum demand of the system being studied under a specific time duration(e.g. annual, monthly, daily etc).
- 2. Light Load:** It is the simultaneous minimum demand of the system being studied under a specific time duration(e.g. annual, monthly, daily etc).
- 3. System Stability:** A stable power system is one in which synchronous machines, when perturbed, will either return to their original state if there is no change in exchange of power or will acquire new state asymptotically without losing synchronism. Usually the perturbation causes a transient that is oscillatory in nature, but if the system is stable the oscillations will be damped.
- 4. Temporary over-voltages:** These are power frequency over-voltages produced in a power system due to sudden load rejection, single phase to ground faults, etc.
- 5. Switching over-voltages:** These are over-voltages generated during switching of lines, transformers and reactors etc, having wave fronts of 250/2500 micro sec.
- 6. Surge Impedance Loading:** It is the unity power factor load over a resistive line such that series reactive loss ( $I^2X$ ) along the line is equal to shunt capacitive gain ( $V^2Y$ ). Under these conditions the sending end and receiving end voltages and current are equal in magnitude but different in phase position.



## ABBREVIATIONS

AC	:	Alternating Current
AUFLS	:	Automatic Under Frequency Load Shedding
BESS	:	Battery Energy Storage System
CEA	:	Central Electricity Authority
CTU	:	Central Transmission Utility
D/c	:	Double Circuit
DISCOM	:	Distribution Company
EMT	:	Electro Magnetic Transient
EPS	:	Electric Power Survey
FACTS	:	Flexible Alternating Current Transmission System
GNA	:	General Network Access
HV	:	High Voltage
HVDC	:	High Voltage Direct Current
ICT	:	Inter-Connecting Transformer
ISGS	:	Inter-State Generating Station
ISTS	:	Inter State Transmission System
Intra-STS	:	Intra-State Transmission System
kA	:	kilo Ampere
km	:	kilo meter
kV	:	kilo Volt
ms	:	millisecond
MVA	:	Million Volt Ampere
MVA <sub>r</sub>	:	Mega Volt Ampere reactive
MW	:	Mega Watt
NR/WR/SR/	:	Northern / Western / Southern /
ER/NER	:	Eastern / North Eastern Region(s)
NLDC	:	National Load Dispatch Centre
P, Q	:	P – Active Power, Q – Reactive Power

$P_{max}$ , $Q_{max}$ , $Q_{min}$	:	$P_{max}$ – Maximum Active Power, $Q_{max}$ – Maximum Reactive Power Supplied i.e. lagging, $Q_{min}$ – Maximum Reactive Power Absorbed i.e. leading
PMGS-NMP	:	Prime Minister Gati-Shakti National Master Plan (PM GatiShakti)
PMU	:	Phasor Measurement Unit
pu	:	per unit
RE	:	Renewable Energy
RES	:	Renewable Energy Source
RLDC	:	Regional Load Dispatch Centre
RoCoF	:	Rate of Change of Frequency
RPC	:	Regional Power Committee
S/c	:	Single Circuit
SLDC	:	State Load Dispatch Centre
STU	:	State Transmission Utility (Generally Transmission Company of the State)
SVC	:	Static VAr Compensator
STATCOM	:	Static Synchronous Compensator
X, Y, Z	:	X – Reactance, Y – Admittance, Z – Impedance
132 kV	:	132 kV System includes 110 kV System wherever used
220 kV	:	220 kV System includes 230 kV system wherever used

# Chapter 1 INTRODUCTION

## 1.1 Background

- 1.1.1 As per the Seventh Schedule to the Constitution of India, the subject electricity is in Concurrent List. This implies that both central and state governments play key roles, and can regulate and operate in the electricity sector. Accordingly, electricity transmission system in India is generally categorised as Inter-State Transmission System (ISTS) and Intra-State Transmission System (Intra-STS). Optimum development of transmission system requires coordinated planning of the Inter- State Transmission Systems (ISTS) and Intra-State Transmission Systems (Intra-STS). CEA is coordinating transmission planning process under Section 73(a) of the Electricity Act, 2003.
- 1.1.2 Manual on Transmission Planning Criteria was first brought out by CEA in 1985 setting the planning philosophy of regional self-sufficiency. The manual was revised in 1994 considering the experience gained on 220 kV and 400 kV systems. Technological advancements and institutional changes necessitated further review of Transmission Planning Criteria.
- 1.1.3 The Electricity Act, 2003 has brought profound changes in electricity supply industry of India leading to unbundling of vertically integrated State Electricity Boards, implementation of Open Access in power transmission and liberalisation of generation sector, among others. The phenomenal growth of private sector generation and the creation of open market for electricity have brought its own uncertainties. Large number of generation projects are coming up with no knowledge of firm beneficiaries. The situation is compounded by uncertainty in generation capacity addition, commissioning schedules and fuel availability. All these factors have made transmission planning a challenging task. Adequate flexibility may be built in the transmission system plan to cater to such uncertainties, to the extent possible. However, given the uncertainties, the possibility of stranded assets or congestion cannot be entirely ruled out. In creation of very large interconnected grid, there can be unpredictable power flows leading to overloading of transmission lines due to imbalance in load generation balance in different pockets of the grid in real time operation. Reliable transmission planning is basically a trade-off between the cost and the risk involved. There are no widely adopted uniform guidelines which determine the criteria for transmission planning vis-à-vis acceptable degree of adequacy and security. Practices in this regard vary from country to country. The common theme in various approaches is "acceptable system performance".
- 1.1.4 As the National grid grew in size and complexity, grid security was required to be enhanced considering large scale integration of renewable energy sources. Therefore, the transmission planning criteria was reviewed again in the year 2013.

- 1.1.5 The regional electrical grids of Northern, Western, Southern, Eastern and North-Eastern regions have been synchronously interconnected in December 2013 to form one of the largest synchronous electrical grid in the world. The country has moved from the concept of regional self-sufficiency to bulk inter-regional transfer of power through high capacity AC and HVDC corridors forming an all-India National Grid.
- 1.1.6 Ministry of Power (MoP) have promulgated Electricity (Transmission System Planning, Development and Recovery of Inter-State Transmission Charges) Rules, 2021 in the Gazette of India on 01.10.2021 paving the way for complete overhauling of transmission system planning to give power sector utilities easier access to electricity transmission network across the country. These Rules underpin that electricity transmission planning shall be done in such way that the lack of availability of the transmission system does not act as a barrier on the growth of different regions and the transmission system shall, as far as possible, be planned and developed matching with the growth of generation and load. While doing the transmission planning, care shall be taken that there is no wasteful investment. These rules also introduced General Network Access (GNA) in the inter-state transmission system.
- 1.1.7 In view of above, there was need to update the Manual on Transmission Planning Criteria issued by CEA in January, 2013 especially in context of anticipated large scale renewable generation capacity addition, growth of load, increasing fault level, right of way issues, technological advancement and notification of Transmission Rules 2021. Accordingly, the planning criteria has been revised again. This planning criteria may be referred as Central Electricity Authority [Manual on Transmission Planning Criteria (with Amendment-I)], 2025.

## **1.2 Scope**

- 1.2.1 The Central Electricity Authority is responsible for preparation of perspective generation and transmission plans and for coordinating the activities of planning agencies as envisaged under Section 73(a) of the Electricity Act, 2003. The Central Transmission Utility (CTU) is responsible for development of an efficient and coordinated inter-state transmission system (ISTS). Similarly, the State Transmission Utility (STU) is responsible for development of an efficient and coordinated intra-state transmission system (Intra-STs). The ISTS and Intra-STs are interconnected and together constitute the electricity grid. It is therefore imperative that there should be a uniform approach to transmission planning for developing a reliable transmission system.
- 1.2.2 The planning criteria detailed herein are primarily meant for planning of Inter-State Transmission System (ISTS), Intra-State Transmission System (Intra-STs) and dedicated transmission lines down to 66 kV level.
- 1.2.3 The manual covers the planning philosophy, the information required from various entities, permissible limits, reliability criteria, broad scope of system

studies, modelling and analysis, and prescribes guidelines for transmission planning.

### **1.3 Applicability**

- 1.3.1 These planning criteria shall be applicable with effect from 1<sup>st</sup> April, 2023.
- 1.3.2 These criteria shall be used for all new transmission systems planned after the above date.
- 1.3.3 The existing and already planned transmission systems may be reviewed with respect to the provisions of these planning criteria. Wherever required and possible, additional system may be planned to strengthen the existing system. Till implementation of the additional system, suitable defence mechanisms may be put in place.

## Chapter 2 PLANNING PHILOSOPHY

### 2.1 General guidelines

- 2.1.1 The transmission system forms a vital link in the electricity supply chain. Transmission system provides 'service' of inter-connection between the source (electrical energy sources) and consumption (load centres) of electricity. In the Indian context, the transmission system has been broadly categorised as Inter-State Transmission System (ISTS) and Intra-State Transmission system (Intra-STS). The ISTS is the top layer of National Grid below which lies the Intra-STS. The smooth operation of power system gets adversely affected on account of any disturbance in these systems. Therefore, the criteria prescribed here are intended to be followed for planning of both ISTS, Intra-STS and dedicated transmission line.
- 2.1.2 The transmission system is generally augmented to cater to the power transfer requirements posed by eligible entities, for example, for increase in power demand, generation capacity addition etc. Further, system may also be augmented considering the feedback regarding operational constraints and feedback from drawing entities.
- 2.1.3 The principle for planning of the ISTS shall be to ensure that it is available as per the requirements of the States and the generators, as reflected by their General Network Access (GNA) requests. As far as possible, the transmission system shall be planned and developed matching with growth of generation and load and care shall be taken that there is no wasteful investment.
- 2.1.4 The transmission customers as well as utilities shall give their network access requirement well in advance considering time required for implementation of the transmission assets. The transmission customers are also required to provide a reasonable basis for their transmission requirement such as size and completion schedule of their generation facility, demand and their commitment to bear transmission service charges.
- 2.1.5 Planning of transmission system for evacuation of power from hydro projects shall be done river basin wise considering the identified generation projects and their power potential.
- 2.1.6 In case of highly constrained areas like congested urban / semi-urban area, very difficult terrain (including hilly terrain) etc., the transmission corridor may be planned by considering long term perspective of optimizing the right-of-way and cost. This may be done by adopting higher voltage levels for final system and operating one level below voltage level in the initial stage, or by using multi-circuit towers for stringing circuits in the future, or using new technology.
- 2.1.7 Routing of the transmission line may be planned in accordance with Central Electricity Authority (Technical Standards for Construction of Electrical Plants

and Electric Lines) Regulations, 2022 and its amendments or re-enactment thereof, to minimise Right of Way (Row), technical options and line configurations.

- 2.1.8 PM Gati Shakti National Master Plan (PMGS-NMP) was launched on 13<sup>th</sup> October 2021 for providing multimodal connectivity infrastructure to various economic zones. It provides a digital platform for integrated planning and coordinated implementation of infrastructure connectivity projects. The information available on this platform to be used while planning of transmission system. For planning of any new transmission lines or substations, the portal of PMGS-NMP to be used. PM-GatiShakti will facilitate optimum route planning of transmission lines by avoiding/minimizing crossing of railways, highways, restricted areas, forest cover, GIB zone, defence, airports and habitat areas etc.<sup>1</sup>
- 2.1.9 In line with Section 39 of the Electricity Act, 2003, STU shall act as the nodal agency for Intra-STS planning in coordination with distribution licensees and intra-state generators connected/to be connected in the STU system. The STU shall be the single point contact for the purpose of ISTS planning and shall be responsible on behalf of all the intra-State entities, for evacuation of power from their State's generating stations, meeting requirements of DISCOMs and exchange of power with ISTS commensurate with the ISTS plan with due consideration to the margins available in existing system.
- 2.1.10 Normally, various intra-state entities shall be supplied power through the intra-state network. Only under exceptional circumstances, the load serving intra-state entity may be allowed direct inter-connection with ISTS on recommendation of STU provided that such an entity would continue as intra-state entity for the purpose of all jurisdictional matters including energy accounting. Under such situation, this direct interconnection may also be used by other intra-state entity(ies). Further, STUs shall coordinate with urban planning agencies, Special Economic Zone (SEZ) developers, industrial developers etc to keep adequate provision for transmission corridor and land for new substations for their power transfer requirements.
- 2.1.11 The system parameters and loading of system elements shall remain within permissible limits. The adequacy of the transmission system should be tested for different probable load-generation scenarios as detailed in chapter-3 of this manual.
- 2.1.12 The system shall be planned to operate within permissible limits both under normal as well as after probable credible contingency(ies) as detailed in subsequent chapters of this manual. However, the system may experience extreme contingencies which are rare, and the system may not be planned for such rare contingencies. To ensure security of the grid, the extreme/rare but

---

<sup>1</sup> Modified vide Amendment-I

credible contingencies should be identified from time to time and suitable defence mechanism, such as - load shedding, generation rescheduling, islanding, system protection schemes, Automatic Under Frequency Load Shedding (AUFLS) schemes (AUF Relay and df/dt Relay), etc may be worked out to mitigate their adverse impact.

- 2.1.13 For strengthening of the transmission network, cost, reliability, right-of-way requirements, transmission losses, down time (in case of up-gradation and re-conductoring options) etc need to be studied. If need arises, addition of new transmission lines / substations to avoid overloading of existing system including adoption of next higher voltage may be explored.
- 2.1.14 Critical loads such as - railways, metro rail, airports, refineries, underground mines, steel plants, smelter plants, hospitals, etc shall plan their interconnection with the grid, with 100% redundancy and as far as possible from two different sources of supply.
- 2.1.15 The planned transmission capacity would be finite and there are bound to be congestions if large quantum of electricity is sought to be transmitted in direction not previously planned.
- 2.1.16 Communication system for new transmission system shall be planned and implemented in accordance with Central Electricity Authority (Technical Standards for Construction of Electrical Plants and Electric Lines) Regulations, 2022 and its amendments or re-enactment thereof, Central Electricity Authority (Technical Standards for Communication System in Power System Operations) Regulations, 2020 and its amendments or re-enactment thereof and CEA Manual of Communication Planning in Power System Operation 2022 and its amendments such that the communication system is available at the time of commissioning of the transmission system.



## Chapter 3 TRANSMISSION PLANNING

### 3.1 Power system data for transmission planning modelling

3.1.1 In order to precisely model the power system for planning studies, accuracy of data is very important, as the same can have considerable effect on outcome of system studies and ultimately on the system planning. The template data format in this regard is enclosed at **Annexure-I**, however, additional data may be required at the time of planning studies.

3.1.2 For ISTS planning, the transmission network may be modelled down to 220 kV level and wherever required such as for North Eastern Region, Uttarakhand, Himachal Pradesh and Sikkim, the transmission network may be modelled down to 132 kV level.

The generating units that are stepped-up at 132 kV may be connected at the nearest 220 kV bus through a 220/132 kV transformer for simulation purpose. The generating units smaller than 50 MW size within a plant may be lumped and modelled as a single unit. Load may be lumped at 220 kV or 132 kV, as the case may be.

3.1.3 For Intra-STS planning, the transmission network may be modelled down to 66 kV level and lumping of generating units and loads may be considered accordingly. The STUs may consider modelling of smaller generating units if required.

3.1.4 For modelling of various elements, actual system data wherever available shall be used. In case where data is not available, standard data given in **Annexure-II** may be used.

### 3.2 Time Horizons for transmission planning

3.2.1 Concept to commissioning of transmission elements generally takes a time of about three to five years; about two to three years for augmentation of capacitors, reactors, transformers etc., and about four to five years for new transmission lines or substations. Therefore, system studies for firming up the transmission plans may be carried out with 3-5 years time horizon on rolling basis every year. These studies may be tested by applying the relevant criteria mentioned in this manual.

### 3.3 Load - generation scenarios

3.3.1 The load-generation scenarios shall be worked out in a pragmatic manner so as to reflect the typical daily and seasonal variations in load demand and generation availability. Typical load generation scenario may include high/low

Wind, high/nil Solar, high/low Hydro generation, high demand, low demand and combinations thereof.

### **3.4 Loads**

#### **3.4.1 Active power (MW)**

- 3.4.1.1 The system peak demands (state-wise, regional and national) shall be based on the latest Electric Power Survey (EPS) report of CEA. However, the same may be moderated based on actual load growth of past five (5) years.
- 3.4.1.2 The load demands at other periods (seasonal variations and minimum loads) shall be derived based on the annual peak demand and past pattern of load variations.
- 3.4.1.3 While carrying out the simulation studies, if the peak load figures are more than the peaking availability of generation, the loads may be suitably adjusted substation-wise to match with the availability. Similarly, if the peaking availability is more than the peak load, the generation dispatches may be suitably reduced, to the extent possible considering merit order dispatch.
- 3.4.1.4 From practical considerations the load variations over the year shall be considered as under:
  - a) Annual Peak Load
  - b) Seasonal variation in Peak Loads for Winter, Summer and Monsoon
  - c) Seasonal Light Load
  - d) Variation of peak load in Region and time of day.
- 3.4.1.5 Actual demand data, wherever available, should be used. In cases where data is not available the load may be calculated using load factors given in Table-I of **Annexure-III**.

#### **3.4.2 Reactive power (MVA<sub>r</sub>)**

- 3.4.2.1 Reactive power plays an important role in transmission system planning and hence forecast of reactive power demand on an area-wise or substation-wise basis is as important as active power forecast. This forecast would obviously require adequate data of the reactive power demands at different substations as well as the projected plans (including existing, if any) for reactive power compensation.
- 3.4.2.2 For developing an optimal ISTS, the STUs must clearly spell out the substation-wise maximum and minimum demand in MW and MVA<sub>r</sub> on seasonal basis. In the absence of MVA<sub>r</sub> data, the load power factor shall be taken as per Central Electricity Authority (Technical Standards for Connectivity to the Grid) Regulations, 2007 and its amendments or re-

enactment thereof. The STUs shall provide adequate reactive compensation to bring power factor as close to unity at 132 kV and 220 kV voltage levels.

- 3.4.2.3 Reactive power capability of generators including RE generators shall be as per provisions of the Central Electricity Authority (Technical Standards for Connectivity to the Grid) Regulations, 2007 and its amendments or re-enactment thereof.

### 3.5 Generation dispatches and modelling

- 3.5.1 For the purpose of development of Load Generation scenarios on all India basis, the all India peaking availability may be calculated as per seasonal and daily variations based on the past pattern of generation variations.

- 3.5.2 For evolving transmission systems for integration of RE generation projects, high wind/solar generation injections may also be studied in combination with suitable conventional dispatch scenarios. In such scenarios, the generation of Intra-State generating station may be adjusted so that ISTS access of the state remain within the limits of General Network Access (GNA) of the state. The maximum generation at a wind/solar aggregation level may be calculated using capacity factors as per the norms given in Table-II of **Annexure - III**.

- 3.6 Special area dispatches such as following may be considered in planning, wherever necessary:

- a) Special dispatches corresponding to high agricultural load/lift irrigation pump schemes with low power factor, wherever applicable.
- b) Complete closure of a generating station close to a major load centre.

- 3.7 In case of coal based thermal power generating units, the minimum level of output (ex-bus generation, i.e. net of the auxiliary consumption) shall be taken as not less than 40% of the rated installed capacity.

- 3.8 The generating units shall be modelled to run as per their respective capability curves. In the absence of capability curve, the reactive power limits ( $Q_{max}$  and  $Q_{min}$ ) for generating units can be taken as under:

Type of generating unit	$Q_{max}$	$Q_{min}$
Thermal units	$Q_{max} = 0.60 \times P_{max}$	$Q_{min} = (-)0.30 \times P_{max}$
Nuclear units	$Q_{max} = 0.50 \times P_{max}$	$Q_{min} = 0$
Hydro units	$Q_{max} = 0.48 \times P_{max}$	$Q_{min} = (-)0.24 \times P_{max}$
Wind / Solar / BESS	$Q_{max} = 0.33 \times P_{max}$	$Q_{min} = (-)0.33 \times P_{max}$

- 3.9 It shall be duty of all the generators to provide technical details of generating units, such as generator (including machine capability curves), exciter, governor, Power System Stabiliser (PSS) parameters etc., for modelling of their

machines for steady-state and transient-state studies. In case of Wind/Solar/BESS, equivalent generator model shall also be provided.

### 3.10 Planning margins

3.10.1 In a very large interconnected grid, there can be unpredictable power flows in real time due to variation in load-generation balance with respect to anticipated load generation balance in different pockets of the grid. This may lead to overloading of transmission elements during operation, which cannot be predicted in advance at the planning stage. This can also happen due to delay in commissioning of a few planned transmission elements, delay/abandoning of planned generation additions or load growth at variance with the estimates. Such uncertainties are unavoidable and hence some margins at the planning stage may help in reducing impact of such uncertainties. However, care also need to be taken to avoid stranded transmission assets. Therefore, at the planning stage, planning margins need to be provided.

3.10.2 Against the requirement of power transfer, the new transmission lines emanating from a power station to the nearest grid point may be planned considering overload capacity of the generating stations in consultation with generators.

3.10.3 The new transmission system additions required for system strengthening may be planned keeping a margin of 10% in the thermal loading limits of lines and transformers. Further, the margins in the interregional links may be kept as 15%.

3.10.4 At the planning stage, a margin of about  $\pm 2\%$  may be kept in the voltage limits and thus the voltages under load flow studies (for 'N-0' and 'N-1' steady-state conditions only) may be maintained within the limits given below:

<b>Voltage (kV<sub>rms</sub>) (after planning margins)</b>		
<b>Nominal</b>	<b>Maximum</b>	<b>Minimum</b>
765	785 (1.03 pu)	745 (0.97 pu)
400	412 (1.03 pu)	388 (0.97 pu)
230	240 (1.04 pu)	212 (0.92 pu)
220	240 (1.09 pu)	203 (0.92 pu)
132	142 (1.08 pu)	125 (0.95 pu)
110	119 (1.08 pu)	102 (0.93 pu)
66	70 (1.06 pu)	62 (0.94 pu)

3.10.5 In planning studies all the transformers may be kept at nominal taps and On Load Tap Changer (OLTC) may not be considered. The effect of the taps should be kept as operational margin.

3.10.6 For the purpose of load flow studies at planning stage, the nuclear power generating units shall normally not run at leading power factor. To keep some

margin at planning stage, the reactive power limits ( $Q_{max}$  and  $Q_{min}$ ) for generating units may be taken as under:

Type of generating unit	$Q_{max}$	$Q_{min}$
Thermal Units	$Q_{max} = 0.50 \times P_{max}$	$Q_{min} = (-)0.10 \times P_{max}$
Nuclear units	$Q_{max} = 0.40 \times P_{max}$	$Q_{min} = 0$
Hydro units	$Q_{max} = 0.40 \times P_{max}$	$Q_{min} = (-)0.20 \times P_{max}$
Wind / Solar / BESS	$Q_{max} = 0.20 \times P_{max}$	$Q_{min} = (-)0.20 \times P_{max}$

*Note: In case of limitation in  $Q_{max}$  and  $Q_{min}$ , similar ratio of margins as provided in Paragraph 3.8 and Paragraph 3.10, shall be considered for the generating unit with respect to capability curve.*

3.10.7 Notwithstanding above, during operation, as per the instructions of the System Operator, the generating units shall operate at leading power factor within their respective capability curves.

### 3.11 System studies for transmission planning

3.11.1 The system shall be planned based on one or more of the following power system studies, as per requirements:

- i) Power Flow Studies
- ii) Short Circuit Studies
- iii) Stability Studies
- iv) TTC/ATC Calculations

3.11.2 Additional studies as given below may be carried out at appropriate time as per requirement.

- i) EMT studies
- ii) System Inertia studies

3.11.3 Details of the studies are discussed in subsequent paragraphs.

### 3.12 Power Flow studies

3.12.1 Load flow study is the steady state analysis of power system network. It determines the operating state of the system for a given load generation balance in the system. It helps in determination of loading on transmission elements and helps in planning and operation of power systems from steady state point of view.

- 3.12.2 All the elements of transmission network viz. transmission lines, transformers, generating resources, load, bus reactors, line reactors, HVDC, FACTS etc. are modelled using steady state parameters in the simulation software.
- 3.12.3 Load flow solves a set of simultaneous non-linear algebraic power equations for the two unknown variables ( $|V|$  and  $\angle\delta$ ) at each node in a system. The output of the load flow analysis is the voltage and phase angle, real and reactive power, losses and slack bus power.
- 3.12.4 The parameters calculated at Paragraph 3.12.3 above should be within the planning margins specified in Paragraph 3.10.

### **3.13 Short circuit studies**

- 3.13.1 The short circuit studies shall be carried out using the classical method with flat pre-fault voltages and sub-transient reactance ( $X''_d$ ) of the synchronous machines.
- 3.13.2 For inverter based generators, the response of an inverter to grid disturbances is a function of the controls programmed into the inverter and the rated capability of the inverter. Wind / Solar / Hybrid plants need to clearly articulate how the inverter would behave during fault events to ensure that the correct response is provided during and immediately following fault conditions. In case of non-availability of data, sub-transient reactance ( $X''_d$ ) for wind and solar generation may be assumed as 0.85 pu and 1 pu respectively for short circuit studies.
- 3.13.3 MVA of all the generating units in a plant may be considered for determining maximum short-circuit level at various buses in the system. This short-circuit level may be considered for substation planning.
- 3.13.4 Vector group of the transformers shall be considered for carrying out short circuit studies for asymmetrical faults. Inter-winding reactances in case of three winding transformers shall also be considered. For evaluating the short circuit levels at a generating bus (11 kV, 13.8 kV, 21 kV etc.), the unit and its generator transformer shall be represented separately.
- 3.13.5 Short circuit level for both, three phase to ground fault, and single phase to ground fault shall be calculated.
- 3.13.6 The short-circuit level in the system varies with operating conditions, it may be low for light load scenario as compared to peak load scenario, as some of the plants / unit(s) may not be on-bar. For getting an understanding of system strength under different load-generation / export-import scenarios, the MVA of only those machines shall be taken into account, which are on bar in that scenario.

### 3.14 Stability studies

- 3.14.1 Power System Stability may be broadly defined as property of a power system that enables it to remain in a state of operating equilibrium under normal operating conditions and to regain an acceptable state of equilibrium after being subjected to a disturbance. Stability is a condition of equilibrium between opposing forces.
- 3.14.2 Rotor Angle Stability is the ability of interconnected synchronous machines of a power system to remain in synchronism. The stability problem involves the study of the electromechanical oscillations inherent in the power system.
- 3.14.3 If the system is perturbed, this equilibrium is upset, resulting in acceleration or deceleration of the rotors of the machines according to the laws of motion of a rotating body. After perturbation, if one generator temporarily runs faster than another, the angular position of its rotor relative to that of the slower machine will advance. The resulting angular difference transfers part of the load from the slower machine to the faster machine, depending on the power-angle relationship. This tends to reduce the speed difference and hence the angular separation. The power-angle relationship is non-linear. Beyond a certain limit, an increase in angular separation is accompanied by a decrease in power transfer; this increases the angular separation further and leads to instability. For any given situation, the stability of the system depends on whether or not the deviations in angular positions of the rotors result in sufficient restoring torques.
- 3.14.4 In transient stability studies, the contingencies usually considered are short-circuits of different types: phase-to-ground, phase-to-phase-to-ground, or three phases to ground. These are usually assumed to occur on transmission lines, but occasionally bus or transformer faults are also considered. The fault is assumed to be cleared by the opening of appropriate circuit breakers to isolate the faulted element. In some cases, high-speed re-closure may be assumed.
- 3.14.5 In transient stability studies, the study period of interest is usually limited to 3 to 5 seconds following the disturbance, although it may extend to about 10 seconds for very large systems with dominant inter-area modes of oscillation.
- 3.14.6 During the analysis, impact due to tripping of one line of a radially connected generator may be studied.
- 3.14.7 Voltage stability is the ability of a power system to maintain steady acceptable voltages at all buses in the system under normal operating conditions and after being subjected to a disturbance. The system enters a state of voltage instability when there is disturbance/ increase in load demand / change in system condition which causes a progressive and uncontrollable drop in voltage. The main factor causing instability is the inability of the power system

to meet the demand for reactive power. The heart of the problem is usually the voltage drop that occurs when active power and reactive power flow through inductive reactances associated with the transmission network.

- 3.14.8 The criterion for voltage stability is that, at a given operating condition for every bus in the system, the bus voltage magnitude increases as the reactive power injection at the same bus is increased. A system is voltage unstable if, for at least one bus in the system, the bus voltage magnitude ( $V$ ) decreases as the reactive power injection ( $Q$ ) at the same bus is increased. In other words, a system is voltage stable if  $V$ - $Q$  sensitivity is positive for every bus and voltage unstable if  $V$ - $Q$  sensitivity is negative for at least one bus.
- 3.14.9 Progressive drop in bus voltages can also be associated with rotor angles going out of step. In contrast, the type of sustained fall of voltage that is related to voltage instability occurs where rotor angle stability is not an issue.
- 3.14.10 Voltage instability is essentially a local phenomenon; however, its consequences may have a widespread impact. Voltage collapse is more complex than simple voltage instability and is usually the result of a sequence of events accompanying voltage instability, leading to a low-voltage profile in a significant part of the power system.
- 3.14.11 The candidate transmission elements for which stability studies may be carried out, may be selected through results of load flow studies. Choice of candidate transmission elements for stability studies are left to transmission planner.
- 3.14.12 Generally, the lines for which the angular difference between its terminal buses is more than 20 degree after contingency of one circuit may be selected for performing stability studies.
- 3.14.13 Voltage Stability Studies: These studies may be carried out using load flow analysis program by creating a fictitious synchronous condenser at critical buses which are likely to have wide variation in voltage under various operating conditions i.e. bus is converted into a PV bus without reactive power limits. By reducing desired voltage of this bus, MVAR generation/ absorption is monitored. When voltage is reduced to some level it may be observed that MVAR absorption does not increase by reducing voltage further instead it also gets reduced. The voltage where MVAR absorption does not increase any further is known as Knee Point of Q-V curve. The knee point of Q-V curve represents the point of voltage instability. The horizontal 'distance' of the knee point to the zero-MVAR vertical axis measured in MVAR is therefore an indicator of the proximity to the voltage collapse.
- 3.14.14 Each bus shall operate above Knee Point of Q-V curve under all normal as well as the contingency conditions detailed in Chapter-4. The system shall have adequate margins in terms of voltage stability.



### 3.15 TTC/ATC Calculation

3.15.1 “Total Transfer Capability (TTC)” means the electric power that can be transferred reliably over the inter-control area transmission system under a given set of operating conditions considering the effect of occurrence of the worst credible contingency as prescribed under reliability criteria in Chapter-4.

3.15.2 “Transmission Reliability Margin (TRM)” means the margin kept in the total transfer capability necessary to ensure that the interconnected transmission network is secure under a reasonable range of uncertainties in the system conditions. The TRM may be considered as minimum of 2% of demand of area/region or size of largest generating unit in that area/region.

3.15.3 “Available Transfer Capability (ATC)” means the transfer capability of the inter-control area transmission system available for scheduling commercial transactions in a specific direction, considering the reliability criteria. Mathematically ATC is the Total Transfer Capability Less Transmission Reliability Margin.

3.15.4 The studies to assess TTC, ATC and TRM of inter-regional or ISTS – Intra-STS transmission corridors for the future timeframe are to be carried out considering the load generation balance and planned transmission system.

3.15.5 While carrying out the studies, limiting condition on some portions of the transmission corridors may shift as the network operating conditions change over time. TTC would be the minimum of the transmission capability arrived at taking into consideration the Thermal, Voltage and Stability loading limits. TRM of the inter-regional corridor would be arrived at by considering the worst credible contingency.

3.15.6 The TTC, ATC and TRM values of transmission corridors may be revised due to change in system conditions, which includes change in network topology/change in anticipated Load-Generation balance for the future study timeframe.

3.15.7 Determination of ATC/TTC at planning stage:

3.15.7.1 Rated System Path (RSP) Method:

The RSP method for ATC calculation is typically used for transmission systems that are characterized by sparse networks. Generally in this approach, transmission paths between areas of the network are identified and based on simulation studies, individual transmission path capabilities are determined. It uses a maximum power flow test to ensure that the transfer path is capable of carrying power flows up to its rated transfer capability or TTC. When determined this way, the TTC rating usually remains fairly constant except for system configuration changes such as a line outage. However, this method is best suitable for a system which does not consist of

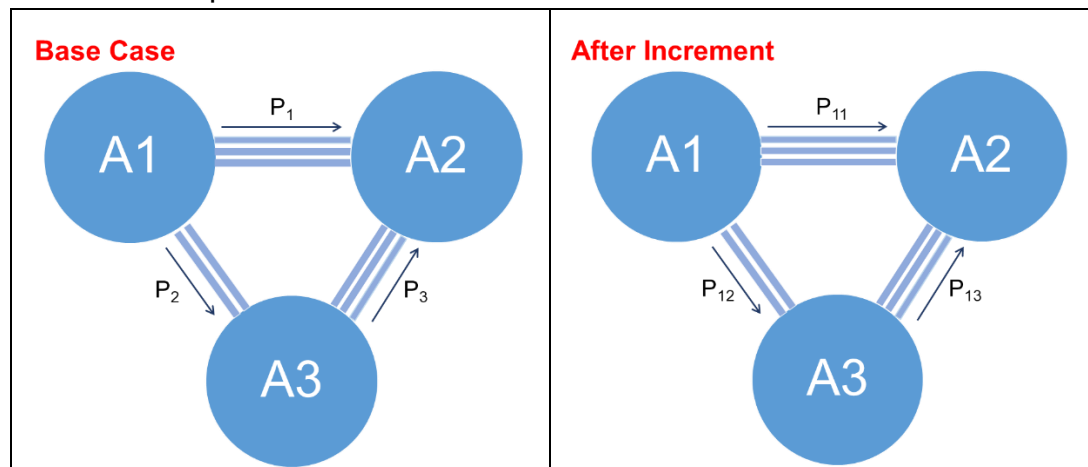
meshed networks and there exist well-defined interfaces between them, or there are good controls on the flows of the paths.

### 3.15.7.2 Area Interchange method:

In this method the power transfer capability in terms of electric power transfer capability between areas are calculated. The presence of flow in parallel paths is taken into account. In this methodology, Load Generation balance is set. TTC is a function of total capacity availability on the most limiting transmission facility. To determine TTC, the Incremental Transfer Capability (ITC) is first determined. ITC is the measure, from a certain starting system condition, how much additional power can be transferred between the areas of interest before pre- or post-contingency limit(s) are reached. Once this ITC limit is found, it is combined with the existing transfers between the areas to come up with the total transfer capability between the areas based on simulation. However, the Incremental Transfer Capability (ITC) is dependent on the power flow between the areas through the parallel corridors.

3.15.7.3 Hybrid of both the above methodology can be adopted to capture the advantages of both methods to arrive at the optimum ATC value. The base case is established considering all network access. On this base value incremental values are calculated. In this method, maximum power transfer between two areas of interest say  $A_1$  to  $A_2$  are determined and the incremental flows both on the direct and parallel paths are noted. Incremental flow on  $A_1$  to  $A_2$  is  $P_{11}$  minus  $P_1$ . Similar values are determined for power transfer between areas  $A_3$  and  $A_2$ .

Now the total power transfer to  $A_2$  is to happen simultaneously from both  $A_1$  and  $A_3$ . TTC between  $A_1$  and  $A_2$  is calculated on base case Power transfer as per load generation balance between  $A_1$  and  $A_2$  plus minimum of ITC between  $A_1$  and  $A_2$  determined by above two conditions. Similar calculations are done for transfer of power from  $A_3$  to  $A_2$ .



### 3.16 EMT studies

- 3.16.1 Electro Magnetic Transient (EMT) study simulate electromagnetic, electromechanical and control system transient on multiphase electric power system.
- 3.16.2 EMT represents the power system and its control system by their differential equations. The solution of these equations is obtained in time domain. The response of the power system to any disturbance can be obtained at any frequency. Typically Temporary Over Voltage, Switching Over Voltage, Ferro resonance, Sub-Synchronous Resonance, Insulation Coordination etc. are performed under EMT studies.
- 3.16.3 During EMT studies transmission elements viz. transmission line, transformer/reactor, Generator, Circuit Breaker, Lightning Arrester, FACTS, etc. are modelled in detail. The equivalent grid is modelled as a constant voltage source behind an impedance. The switching sequence of the model under study is carried out as per requirement of Temporary Over Voltage (TOV) in the study analysis.
- 3.16.4 Temporary Over Voltage (TOV): TOVs are undamped or little damped power-frequency overvoltages of relatively long duration (i.e., seconds, even minutes). They are often preceded by a transient overvoltage resulting from a switching operation, sudden load rejection, single line to ground fault etc. in a no / lightly loaded system. EMT studies provides to characterize TOV, determine resulting problems, and evaluate mitigation alternatives.
- 3.16.5 Switching Over Voltage: When a circuit breaker of an overhead transmission line is closed and line is energised, some switching transients are generated in the power system. Lightning and switching are two primary causes of transient overvoltage in power systems. Switching transients are an important factor in the equipment selection, protection and conductor clearances. Transmission Line Models with frequency dependent parameters are usually used for accurate modelling of transmission lines during switching overvoltage evaluation.
- 3.16.6 Sub-Synchronous Resonance (SSR): Generally, the series compensated transmission lines may cause SSR in the turbine generators, such that it leads to the electrical instability at sub synchronous frequencies resulting in turbine-generator shaft failures.
- 3.16.7 Insulation Coordination: Insulation Coordination is a method /procedure to select the dielectric strength of equipment vis-à-vis operating voltages and transient over-voltages which may appear on the system for which the equipment is designed / intended to operate.
- 3.16.8 Ferro resonance:

- 3.16.8.1 Ferro resonance is a general term applied to a wide variety of interactions between capacitors and iron-core inductors that result in unusual voltages and/or currents. In linear circuits, resonance occurs when the capacitive reactance equals the inductive reactance at the frequency at which the circuit is driven. Iron-core inductors have a non-linear characteristic and have a range of inductance values. Therefore, there may not be a case where the inductive reactance is equal to the capacitive reactance, but yet very high and damaging overvoltage occurs.
- 3.16.8.2 In power system, Ferro resonance occurs when a nonlinear inductor is fed from a series capacitor. The nonlinear inductor in power system can be due to: a) The magnetic core of a wound type voltage transformer, b) Bank type transformer, c) The complex structure of a 3 limb three-phase power transformer (core type transformer), d) The complex structure of a 5 limb three-phase power transformer (shell-type transformer).
- 3.16.8.3 Power transformers, under no-load or light-load conditions, are prone to be driven into Ferro resonance when energized through a long overhead lines or series compensated (FSC/TCSC) lines or underground cable (capacitive connection). Power transformer connected to a de-energized transmission line running in parallel with energized line can also drive the power transformer into Ferro resonance.
- 3.16.8.4 From the HVDC point of view, Ferro resonance should be eliminated to avoid unnecessary protective actions due to high levels of harmonic distortion.
- 3.16.8.5 Therefore, system study for Ferro-resonance may be carried out for the selective locations such as line with series capacitance and lightly loaded transformers etc.

### **3.17 System Inertia**

- 3.17.1 Inertia is the property which resists change in its existing state. In power system, it refers to the energy stored in large rotating generators, which gives them the tendency to remain rotating. Inertia plays an important role in arresting the frequency drop during contingencies. In the grid, it gives the system operator a chance to respond to power plant failures giving other systems time to respond and rebalance supply and demand.
- 3.17.2 With the high penetration of renewable energy sources like wind and solar power and gradual reduction/decommissioning of conventional generators, total system inertia of grid would decline. However, Battery Energy Storage Systems (BESS), Synchronous Condenser etc. can provide fast response to arrest the frequency decline and help restore the frequency.
- 3.17.3 Determination of system inertia is essential for frequency stability assessment. Studies for assessing the system inertia would require modelling of individual

generators including Wind / Solar plants. Data for the same has to be provided by generating companies.

3.17.4 The rate of change of frequency (RoCoF, in Hertz per second or Hz/s) shall be calculated based on simulation studies for the lowest inertia period (usually the highest RE penetration period or lowest demand period).

Following contingencies may be considered for the RoCoF calculation purpose

- Generation Contingency: The largest generating station including RE in the system or the station whose loss produces the highest RoCoF.
- Load Contingency: The largest load in the system (generally an industrial load).
- Determine whether the calculated RoCoF is lower than the maximum permissible RoCoF value.
- The maximum permissible RoCoF shall be such that the 1<sup>st</sup> stage Under Frequency Load Shedding (UFLS) doesn't get triggered and frequency remains 0.1 Hz above 1<sup>st</sup> stage of UFLS.

## Chapter 4 CRITERIA FOR CONTINGENCY

### 4.1 General Principles

The transmission system shall be planned considering following general principles:

- 4.1.1 In normal operation ('N-0') of the grid, with all elements to be available in service in the time horizon of study, it is required that all the system parameters like voltages, loadings, frequency should remain within permissible normal limits.
- 4.1.2 The grid may however be subjected to outage / loss of an element and it is required that after loss of an element ('N-1' or single contingency), all the system parameters like voltages, loadings, frequency shall be within permissible normal limits.
- 4.1.3 Under outage / loss of an element, the grid may experience another contingency, though less probable ('N-1-1'), wherein some of the equipment may be loaded up to their emergency limits. To bring the system parameters back within their normal limits, load shedding/re-scheduling of generation may have to be done, either manually or through automatic system protection schemes (SPS). Such measures shall generally be applied within one hour after the disturbance.

### 4.2 Permissible normal and emergency limits

- 4.2.1 Normal thermal ratings and normal voltage limits represent equipment limits that can be sustained on continuous basis. Emergency thermal ratings and emergency voltage limits represent equipment limits that can be tolerated for a relatively short time which may be one hour to two hours, depending on design of the equipment. The normal and emergency ratings to be used in this context are given in subsequent paragraphs.
- 4.2.2 The loading limit for a transmission line shall be its thermal loading limit. The thermal loading limit of a line is determined by design parameters based on ambient temperature, maximum permissible conductor temperature, wind speed, solar radiation, absorption coefficient, emissivity coefficient etc. In India, all the above factors and more particularly ambient temperatures in various parts of the country are different and vary considerably during various seasons of the year. However, during planning, the ambient temperature and other factors are assumed to be fixed, thereby permitting margins during operation. Generally, the ambient temperature may be taken as 45 deg Celsius; however, in some areas like hilly areas where ambient temperatures are less, the same may be taken. The maximum permissible thermal line loadings for different types of line configurations, employing various types of conductors, are given in Table-II of **Annexure-II**.

- 4.2.3 Design of transmission lines with various types of conductors should be based on conductor temperature limit, right-of-way optimization, losses in the line, cost and reliability considerations etc.
- 4.2.4 The loading limit for an inter-connecting transformer (ICT) shall be its name plate rating.
- 4.2.5 During planning, a margin as specified in Paragraph: 3.10 shall be kept in the above lines/transformers loading limits.
- 4.2.6 The emergency thermal limits for the purpose of planning shall be 120% of the normal thermal limits for one hour and 110% of the normal thermal limits for two hours.
- 4.2.7 In real time system operation, capacity of transmission line may be assessed through Dynamic Line Loading, however, this may not be used while transmission system planning.

### 4.3 Voltage limits

- a) The steady-state voltage limits are given below. However, at the planning stage a margin as specified at Paragraph: 3.10 may be kept in the voltage limits.

<b>Voltages (kV<sub>rms</sub>)</b>				
<b>Nominal</b>	<b>Normal rating</b>		<b>Emergency rating</b>	
	<b>Maximum</b>	<b>Minimum</b>	<b>Maximum</b>	<b>Minimum</b>
765 (1 pu)	800 (1.05 pu)	728 (0.95 pu)	800 (1.05 pu)	713 (0.93 pu)
400 (1 pu)	420 (1.05 pu)	380 (0.95 pu)	420 (1.05 pu)	372 (0.93 pu)
230 (1 pu)	245 (1.07 pu)	207 (0.90 pu)	245 (1.07 pu)	202 (0.88 pu)
220 (1 pu)	245 (1.11 pu)	198 (0.90 pu)	245 (1.11 pu)	194 (0.88 pu)
132 (1 pu)	145 (1.10 pu)	122 (0.92 pu)	145 (1.10 pu)	119 (0.90 pu)
110 (1 pu)	123 (1.12 pu)	99 (0.90 pu)	123 (1.12 pu)	97 (0.88 pu)
66 (1 pu)	72.5 (1.10 pu)	60 (0.91 pu)	72.5 (1.10 pu)	59 (0.89 pu)

- b) Temporary over voltage limits due to sudden load rejection:
- i) 800 kV system 1.4 p.u. peak phase to neutral (653 kV = 1 p.u.)
  - ii) 420 kV system 1.5 p.u. peak phase to neutral (343 kV = 1 p.u.)
  - iii) 245 kV system 1.8 p.u. peak phase to neutral (200 kV = 1 p.u.)
  - iv) 145 kV system 1.8 p.u. peak phase to neutral (118 kV = 1 p.u.)
  - v) 123 kV system 1.8 p.u. peak phase to neutral (100 kV = 1 p.u.)
  - vi) 72.5 kV system 1.9 p.u. peak phase to neutral (59 kV = 1 p.u.)
- c) Switching over voltage limits:
- i) 800 kV system 1.9 p.u. peak phase to neutral (653 kV = 1 p.u.)
  - ii) 420 kV system 2.5 p.u. peak phase to neutral (343 kV = 1 p.u.)

## **4.4 Reliability criteria**

### **4.4.1 No contingency ('N-0')**

- a) The system shall be tested for all the load-generation scenarios as given in this document at Paragraph 3.3.
- b) For the planning purpose all the equipment shall remain within their normal thermal loadings and voltage ratings.
- c) The angular separation between adjacent buses shall not exceed 30 degree.

### **4.4.2 Single contingency ('N-1')**

#### **4.4.2.1 Steady-state:**

- a) All the equipment in the transmission system shall remain within their normal thermal and voltage ratings after outage / loss of any one of the following elements (called single contingency or 'N-1'), but without load shedding / rescheduling of generation:
  - Outage of a 132 kV single circuit,
  - Outage of a 220 kV single circuit,
  - Outage of a 400 kV single circuit (with or without fixed series capacitor),
  - Outage of an Inter-Connecting Transformer (ICT) / power transformer,
  - Outage of a 765 kV single circuit
  - Outage of one pole of HVDC bipole
- b) The angular separation between adjacent buses under 'N-1' shall not exceed 30 degree.
- c) 'N-1' criteria for FACTS devices may not be considered, however studies may be carried out to address the issues like reduction in transfer capability, restriction on generation evacuation etc. in case of outage of FACTS devices.

#### **4.4.2.2 Transient-state:**

Usually, perturbation causes a transient that is oscillatory in nature, but if the system is stable, the oscillations will be damped. The system is said to be stable in which synchronous machines, when perturbed, will either return to their original state, if there is no change in exchange of power or will acquire new state asymptotically without losing synchronism. The transmission system shall be stable after it is subjected to one of the following outage / loss:

- a) The system shall be able to survive a permanent three phase to ground fault on a 765 kV line close to the bus to be cleared in 100 ms.



- b) The system shall be able to survive a permanent single phase to ground fault on a 765 kV line close to the bus. Accordingly, single pole opening (100 ms) of the faulted phase and unsuccessful re-closure (dead time 1 second) followed by 3-pole opening (100 ms) of the faulted line shall be considered.
- c) The system shall be able to survive a permanent three phase to ground fault on a 400 kV line close to the bus to be cleared in 100 ms.
- d) The system shall be able to survive a permanent single phase to ground fault on a 400 kV line close to the bus. Accordingly, single pole opening (100 ms) of the faulted phase and unsuccessful re-closure (dead time 1 second) followed by 3-pole opening (100 ms) of the faulted line shall be considered.
- e) In case of 220 kV / 132 kV network, the system shall be able to survive a permanent three phase fault on one circuit, close to a bus, with a fault clearing time of 160 ms (8 cycles) assuming 3-pole opening.
- f) The system shall be able to survive a fault in HVDC convertor station, resulting in permanent outage of one of the poles of HVDC Bipole.
- g) Loss of generation: The system shall remain stable under the loss of single largest generating unit or a critical generating unit (choice of candidate critical generating unit is left to the transmission planner).
- h) Loss of largest radial load, connected at single point.

#### 4.4.3 **Second contingency ('N-1-1')**

4.4.3.1 Under the scenario as defined at Paragraph 4.4.2 the system may experience another contingency (called 'N-1-1'):

- a) The system shall be able to survive a temporary single phase to ground fault on a 765 kV line close to the bus. Accordingly, single pole opening (100 ms) of the faulted phase and successful re-closure (dead time 1 second) shall be considered.
- b) The system shall be able to survive a permanent single phase to ground fault on a 400 kV line close to the bus. Accordingly, single pole opening (100 ms) of the faulted phase and unsuccessful re-closure (dead time 1 second) followed by 3-pole opening (100 ms) of the faulted line shall be considered.
- c) In case of 220 kV / 132 kV network, the system shall be able to survive a permanent three phase fault on one circuit, close to a bus, with a fault clearing time of 160 ms (8 cycles) assuming 3-pole opening.

4.4.3.2 In the 'N-1-1' as stated above, if there is a temporary fault, the system shall not lose the second element after clearing of fault but shall successfully survive the disturbance.

4.4.3.3 In case of permanent fault, the system shall lose the second element as a result of fault clearing and thereafter, shall asymptotically reach to a new steady state without losing synchronism. In this new state, the system parameters (i.e. voltages and line loadings) shall not exceed emergency limits, however, there may be requirement of load shedding / rescheduling of generation so as to bring system parameters within normal limits.

#### 4.4.4 **Radially connected generation with the grid**

For the transmission system connecting generator(s) radially with the grid, the following criteria shall apply:

4.4.4.1 The radial system shall meet 'N-1' reliability criteria as given at Paragraph 4.4.2 for both the steady-state as well as transient-state.

4.4.4.2 For subsequent contingency i.e. 'N-1-1' (as given at Paragraph 4.4.3), only temporary fault shall be considered for the radial system.

4.4.4.3 If the 'N-1-1' contingency is of permanent nature or any disturbance/contingency causes disconnection of such generator(s) from the main grid, the remaining main grid shall asymptotically reach to a new steady-state without losing synchronism after loss of generation. In this new state the system parameters shall not exceed the emergency limits, however, there may be requirement of load shedding / rescheduling of generation so as to bring system parameters within normal limits.

4.4.5 The 'N-1' criteria may not be applied to the immediate connectivity system of renewable generations with the ISTS/Intra-STS grid i.e. the line connecting the generation project switchyard to the grid and the step-up transformers at the grid station.

Provided that, 'N-1' criteria shall be applicable in case of renewable generation projects with storage, which are firm in nature and fully dispatchable.

Provided that, 'N-1' reliability criteria may be considered for ICTs at the ISTS / STU pooling stations for renewable energy based generation of more than 1000 MW after considering the capacity factor of renewable generating stations.

## Chapter 5 SUBSTATION CRITERIA

### 5.1 General criteria

- 5.1.1 The requirements in respect of transmission sub-stations in a system such as the total load to be catered by the sub-station of a particular voltage level, its MVA capacity, number of feeders permissible etc. are important to the planners so as to provide an idea to them about the time for going in for the adoption of next higher voltage level sub-station and also the number of substations required for meeting a particular quantum of load. Keeping these in view, the substation planning criteria have been laid down in this Chapter.
- 5.1.2 There may be need for upgradation of the system or renovation and modernization of the existing system depending on technological options and system studies. Therefore, transmission licensee shall provide details to CEA/CTU/STUs of the transmission equipment which are required to be upgraded or for which renovation and modernization needs to be carried out.
- 5.1.3 As far as possible, an incoming and an outgoing feeder of same voltage level in a substation may be terminated in bays of same diameter in one and half breaker switching scheme, so as to make direct connection in case of outage of the substation, especially in case of Loop-in Loop-out of existing line(s).
- 5.1.4 The overhead transmission line approaching a substation shall normally be perpendicular to the substation boundary for a stretch of 2-3 km.
- 5.1.5 The maximum short-circuit level on any new substation bus should not exceed 80% of the rated short circuit capacity of the substation equipment. The 20% margin is intended to take care of the increase in short-circuit levels as the system grows. The rated breaking current capability of switchgear at different voltage levels may be taken as given below:

Voltage Level	Rated Breaking Capacity
765 kV	50 kA / 63 kA
400 kV	63 kA / 80 kA
220 kV	40 kA / 50 kA / 63 kA
132 kV	25 kA / 31.5 kA / 40 kA
66kV	31.5 kA

Measures such as sectionalisation of bus, series reactor, or any new technology may also be adopted to limit the short circuit levels at existing substations wherever short circuit levels are likely to cross the designed limits.

- 5.1.6 Rating of the various substation equipment shall be such that they do not limit the loading limits of connected transmission lines.
- 5.1.7 Connection arrangement of switchable line reactors shall be such that it can be used as line reactor as well as bus reactor with suitable neutral grounding resistor (NGR) bypass arrangement.

## 5.2 Transformers

- 5.2.1 Sub-stations may be classified into two categories i.e. (i) Load Serving Sub-station (LSS); where loads are connected (ii) Generation Pooling Sub-station (GPS); where generating stations are connected directly or through dedicated transmission line for evacuation of their power.

Provided that the substations where both generator(s) and load(s) are connected, shall be treated as load serving sub-station.

- 5.2.2 The capacity of any single sub-station at different voltage levels shall not normally exceed as given in column (B) and (C) in the following table:

Voltage Level (A)	Transformation Capacity	
	Load Serving Substation (B)	Generation Pooling substations (C)
765 kV	9000 MVA	9000 MVA
400 kV	2500 MVA	5000 MVA
220 kV	1000 MVA	1000 MVA
132 kV	500 MVA	500 MVA
66 kV	160 MVA	160 MVA

- 5.2.3 Size and number of interconnecting transformers (ICTs) shall be planned in such a way that the outage of any single unit would not over load the remaining ICT(s) or the underlying system

Provided that for immediate connectivity of RE plants, Paragraph 4.4.5 may be referred.

- 5.2.4 While augmenting the transformation capacity at an existing substation or planning a new substation, the fault level at the substation shall also be kept in view. If the fault level is low, the voltage stability studies shall be carried out.

## 5.3 Bus- Sectionalisation

- 5.3.1 To have minimum disruption during struck breaker condition, the bus switching scheme provided in Central Electricity Authority (Technical Standards for Construction of Electrical Plants and Electric Lines) Regulations, 2022 and its amendments or re-enactment thereof shall be implemented.

- 5.3.2 Sources and loads should be mixed in each diameter to maximize reliability in 'one and half breaker scheme' during planning of a new substation. Hence, one double circuit line consisting of two feeders and originating from a transmission or generating switchyard shall not be terminated in one diameter. Similarly, termination of two numbers of transformers of identical primary voltage rating in one diameter of 'one and half breaker scheme' shall be avoided so that sudden outage is minimized. Layout and bus switching scheme of a substation

shall be planned in such way that it shall have maintainability, operation flexibility, security and reliability.

- 5.3.3 Bus switching scheme shall be as per Central Electricity Authority (Technical Standards for Construction of Electrical Plants and Electric Lines) Regulations, 2022 and its amendments or re-enactment thereof. Bus section shall be planned in such a way that feeders are adequately distributed with respect to power flow with bus sectionalizers open condition. Further, sectionaliser arrangement may be implemented also keeping in view transformation capacity in each section, fault current rating adopted, number of feeders etc.

## **5.4 Reactive Power compensation**

### **5.4.1 General:**

- 5.4.1.1 Requirement of reactive power compensation through shunt capacitors, shunt reactors (bus reactors or line reactors), static VAr compensators, fixed series capacitor, variable series capacitor (thyristor controlled) or other FACTS devices shall be assessed through appropriate studies.
- 5.4.1.2 Near to large RE complex(es) synchronous condenser(s) may be planned for dynamic voltage support, in addition to FACTS devices.
- 5.4.1.3 While planning of bus capacitors/reactors, aspects such as voltage sensitivity due to switching of these devices, size, reliability (contingency) etc. shall be considered.
- 5.4.1.4 Space provision shall be kept for converting fixed line reactors/switchable line reactors to be usable as bus reactors after line opening with bypass arrangement for NGR/control switching.
- 5.4.1.5 RE generators to have provision to operate the generators in voltage control mode, fixed-Q and power factor control mode as per the grid requirements.
- 5.4.1.6 While planning Bus Reactor (BR), size, reliability aspect (outage of BR), etc. may be kept in view.

### **5.4.2 Shunt capacitors**

- 5.4.2.1 Reactive Compensation shall be provided as far as possible in the low voltage systems with a view to meet the reactive power requirements of load close to the load points, thereby avoiding the need for VAr transfer from high voltage system to the low voltage system. In the cases where network below 132 kV/220 kV voltage level is not represented in the system planning studies, the shunt capacitors required for meeting the reactive power requirements of loads shall be provided at the 132 kV/220 kV buses for simulation purpose.
- 5.4.2.2 It shall be the responsibility of the respective utility to bring the load power factor as close to unity as possible by providing shunt capacitors at appropriate places in their system.

5.4.2.3 Reactive power flow through 400/220 kV or 400/132 kV or 220/132(or 66) kV or 220/33 kV ICTs, shall be minimal. Wherever voltage on HV side of such an ICT is less than 0.975 pu no reactive power shall flow down through the ICT. Similarly, wherever voltage on HV side of the ICT is more than 1.025 pu no reactive power shall flow up through the ICT. These criteria shall apply under the N-0 conditions. It shall be responsibility of respective STU to plan suitable reactive compensation in their network including at 220 kV and 132 kV levels connected to ISTS, in order to fulfil this provision.

#### 5.4.3 Shunt reactors

5.4.3.1 Bus reactors shall be provided at substations for controlling voltages within the limits [defined in the Paragraph: 4.3(a)] without resorting to switching-off the lines. The bus reactors may also be provided at generation switchyards to supplement reactive capability of generators. The size of reactors should be such that under steady state condition, switching on and off of the reactors shall not cause a voltage change exceeding 5%. The standard sizes (MVAR) of reactors are:

<b>Voltage Level</b>	<b>Standard sizes of reactors (in MVAR)</b>
132 kV (3-ph unit)	12.5 and 25 (rated at 145 kV)
220 kV (3-ph unit)	50, 25 (rated at 245 kV)
400 kV (3-ph unit)	50, 63, 80, 125 and 250 (rated at 420 kV)
765 kV (1-ph unit)	80 and 110 (rated at $765/\sqrt{3}$ kV)

5.4.3.2 Fixed line reactors may be provided to control power frequency temporary over-voltage (TOV) after all voltage regulation action has taken place within the limits as defined in Paragraph: 4.3(b) under all probable operating conditions.

5.4.3.3 Line reactors (switchable/ controlled/ fixed) may be provided if it is not possible to charge transmission line without exceeding the maximum voltage limits given in Paragraph: 4.3(a). The possibility of reducing pre-charging voltage of the charging end shall also be considered in the context of establishing the need for reactors.

5.4.3.4 The line reactors may be planned as switchable wherever the voltage limits, without the reactor(s), remain within limits specified for TOV conditions given at Paragraph: 4.3(b).

#### 5.4.4 Shunt FACTS devices

5.4.4.1 Shunt FACTS devices such as Static VAr Compensation (SVC) and STATCOM shall be provided where found necessary to damp the power swings and provide the system stability under conditions defined in the 'Reliability Criteria' (Paragraph 4.4). As far as possible, the dynamic range of static compensators shall not be utilized under steady state operating condition.

### 5.4.5 Synchronous Condenser

- 5.4.5.1 A synchronous condenser (SC) is a synchronous machine operating without a prime mover. Reactive power output regulation of SC is performed by regulating the excitation current. The level of excitation determines if the synchronous condenser generates or consumes reactive power. SC provides improved voltage regulation and stability by continuously generating/absorbing reactive power, improved short-circuit strength and frequency stability by providing inertia.
- 5.4.5.2 The conventional power stations could be refurbished to a synchronous condenser, thereby potentially reducing initial capital cost. A synchronous condenser consumes a small amount of active power from the system to cover losses. As many gas and coal-based synchronous generators approach the end of their life, the retiring of a plant can possibly create a reactive power deficit at the local network, which may impact voltage stability. The conversion of the existing generator to a synchronous condenser can be potentially economical and effective.
- 5.4.5.3 Operating Hydro generators in synchronous condenser mode may be a possible way for voltage control with the existing resources, which may be explored to regulate voltage in grid locally and thus preventing the switching of other elements for voltage control purpose, which in turn help in keeping the system reliability intact.

## Chapter 6 ADDITIONAL CRITERIA

### 6.1 Wind / Solar / Hybrid projects

- 6.1.1 All the generation projects based on renewable energy sources shall comply with Central Electricity Authority (Technical Standards for Connectivity to the Grid) Regulations, 2007 and its amendments or re-enactment thereof, for which requisite system studies shall be carried out by renewable generation project developer.
- 6.1.2 Connectivity/GNA quantum shall be considered while planning the evacuation system, both for immediate connectivity with the ISTS/Intra-STS and for onward transmission requirement.
- 6.1.3 As the generation of energy at a wind farm is possible only with the prevalence of wind, the thermal line loading limit of the lines connecting the wind farms to the pooling substations may be assessed considering 12 km/hour wind speed.

### 6.2 Nuclear power stations

- 6.2.1 In case of transmission system associated with a nuclear power station, there shall be two independent sources of power supply for the purpose of providing start-up power. Further, the angular separation between start-up power source and the generation switchyard should be, as far as possible, be maintained within 10 degrees.
- 6.2.2 The evacuation system shall generally be planned so as to terminate it at large load centres to facilitate islanding of the power station in case of contingency.
- 6.2.3 Adequate reactive power compensation shall be provided at generation switchyard so as to maintain power factor in accordance with Central Electricity Authority (Technical Standards for Connectivity to the Grid) Regulations, 2007 and its amendments or re-enactment thereof.

### 6.3 HVDC Transmission System

- 6.3.1 The option of HVDC bipole may be considered for transmitting bulk power (more than 2000 MW) over long distance (preferably more than 700 km). HVDC transmission may also be considered in the transmission corridors that have AC lines carrying heavy power flows (total more than 5000 MW) to control and supplement the AC transmission network.
- 6.3.2 The ratio of fault level in MVA at any of the convertor station (for conventional current source type), to the power flow on the HVDC bipole shall not be less than 3.0 under any of the load-generation scenarios given in chapter-3 and reliability criteria given at Paragraph: 4.4. Further, in areas where multiple



Conventional HVDC bipoles are feeding power (multi infeed), the appropriate studies may be carried at planning stage so as to avoid commutation failure.

## 6.4 Zone-3 settings

6.4.1 The transmission utilities shall ensure that zone-3 relay settings of the transmission lines is such that they do not trip at extreme loading of line. For this purpose, the extreme loading may be taken as 120% of thermal current loading limit and assuming 0.9 per unit voltage (i.e. 360 kV for 400 kV system, 689 kV for 765 kV system). In case it is not practical to set the Zone-3 in the relay to take care of above, the transmission licensee/owner shall inform CEA, RPCs<sup>2</sup>, CTU/STU and RLDC/SLDC along with setting (primary impedance) value of the relay. Mitigating measures shall be taken at the earliest and till such time the permissible line loading for such lines would be limited to as calculated from relay impedance assuming 0.95 pu voltage, provided it is permitted by stability and voltage limit considerations as assessed through appropriate system studies.

## 6.5 Resiliency

6.5.1 The IEEE Technical Report PES-TR65 defines resilience as “The ability to withstand and reduce the magnitude and/or duration of disruptive events, which includes the capability to anticipate, absorb, adapt to, and/or rapidly recover from such an event”. This may also be simply defined as “The ability to protect against and recover from any event that would significantly impact the grid”.

### 6.5.2 Resilience v/s Reliability:

The IEEE defines Reliability as “The probability that a system will perform its intended functions without failure, within design parameters, under specific operating conditions, and for a specific period of time.” Further different utilities worldwide have defined and developed different reliability standards for robustness, resourcefulness, rapid recovery and adaptability of their power systems.

The IEEE Technical Report PES-TR83 states that reliability is a system performance measure, and resilience is a system characteristic. Generally better reliability results in better resilience and vice versa. However, in some cases, a highly reliable system may have lower resilience and vice versa. The primary difference between reliability and resilience is that resilience encompasses all events, including “High Impact – Low Frequency” events commonly excluded from the reliability calculations.

---

<sup>2</sup> Inserted vide Amendment-I

6.5.3 Resilience Evaluation: Several frameworks and methods for advancing resilience evaluation have been developed in the last decade. These frameworks can be grouped into two general categories: qualitative and quantitative frameworks.

- i) **Qualitative Frameworks:** Qualitative frameworks usually evaluate the power system's resilience, along with other interdependent systems, such as information systems, fuel supply chain, and other such infrastructures. These frameworks evaluate resilience capabilities such as preparedness, mitigation, response, and recovery. Qualitative frameworks are appropriate for long-term planning because they provide a comprehensive and holistic depiction of system resilience.
- ii) **Quantitative Frameworks:** Quantitative frameworks are based on the quantification of system performance. Resilience is quantitatively evaluated based on the reduced magnitude and duration of deviations from the targeted or acceptable performance. Quantitative resilience metrics should be: 1) performance-related, 2) event-specific, 3) capable of considering uncertainty, and 4) useful for decision making.

An effective resiliency framework should strive to minimize the likelihood and impacts of a disruptive event from occurring and provides the right guidance and resources to respond and recover effectively and efficiently when an incident occurs. This can be accomplished by applying the framework towards assessing and developing a mitigation program with the five main focus areas: Prevention, Protection, Mitigation, Response, and Recovery.

6.5.4 The Recommended Measures in the “Report of Task Force on Cyclone Resilient Robust Electricity Transmission and Distribution Infrastructure in the Coastal Areas” accepted by Ministry of Power vide letter dated 10<sup>th</sup> June, 2021 for Creating Resilient Transmission Infrastructure may be referred.

## 6.6 Economic Analysis

6.6.1 In order to identify the most suited techno-economical transmission system, it is essential to carry out economic analysis of planned alternatives. Therefore, to carry out cost-benefit/economic analysis for each of the planned alternatives, following estimated figures may be computed.

- a) project cost,
- b) annual transmission charges and
- c) impact on the existing total annual transmission charges.

## 6.7 Right of Way (RoW)

6.7.1 For laying electricity transmission lines, licensee erects towers at stipulated intervals and conductors are strung on these towers maintaining a safe height depending on the voltage and other geographical parameters. The tower base

area and corridor of land underneath the strung conductors between two towers forms RoW. The maximum width of RoW corridor is calculated on the basis of tower design, span, wind speed, maximum sag of conductor and its swing plus other requirement of electric safety.

6.7.2 In order to reduce RoW, the technological options for reducing the tower footing/base, area/corridor requirements may be explored.

6.7.3 Central Electricity Authority (Technical Standards for Construction of Electric Plants and Electric Lines) Regulations, 2022, provides that, Right of way for transmission lines shall be optimized keeping in view the corridor requirement for the future by adopting suitable alternative of multi-circuit or multi-voltage lines as applicable. Following may be adopted to optimise RoW utilisation:

- Application of Series Capacitors, FACTS devices and phase-shifting transformers in existing and new transmission systems to increase power transfer capability.
- Up-gradation of the existing AC transmission lines to higher voltage using existing line corridor.
- Re-conductoring of the existing AC transmission line with higher ampacity conductors.
- Use of multi-voltage level and multi-circuit transmission lines.
- Use of narrow base towers and pole type towers in semi-urban / urban areas keeping in view cost and right-of-way optimization.
- Use of HVDC transmission – both conventional as well as voltage source convertor (VSC) based.

## Chapter 7      **PROCEDURE FOR PLANNING OF ELECTRIC POWER TRANSMISSION SYSTEM<sup>3</sup>**

### **7.1 Planning of Electric Power Transmission System**

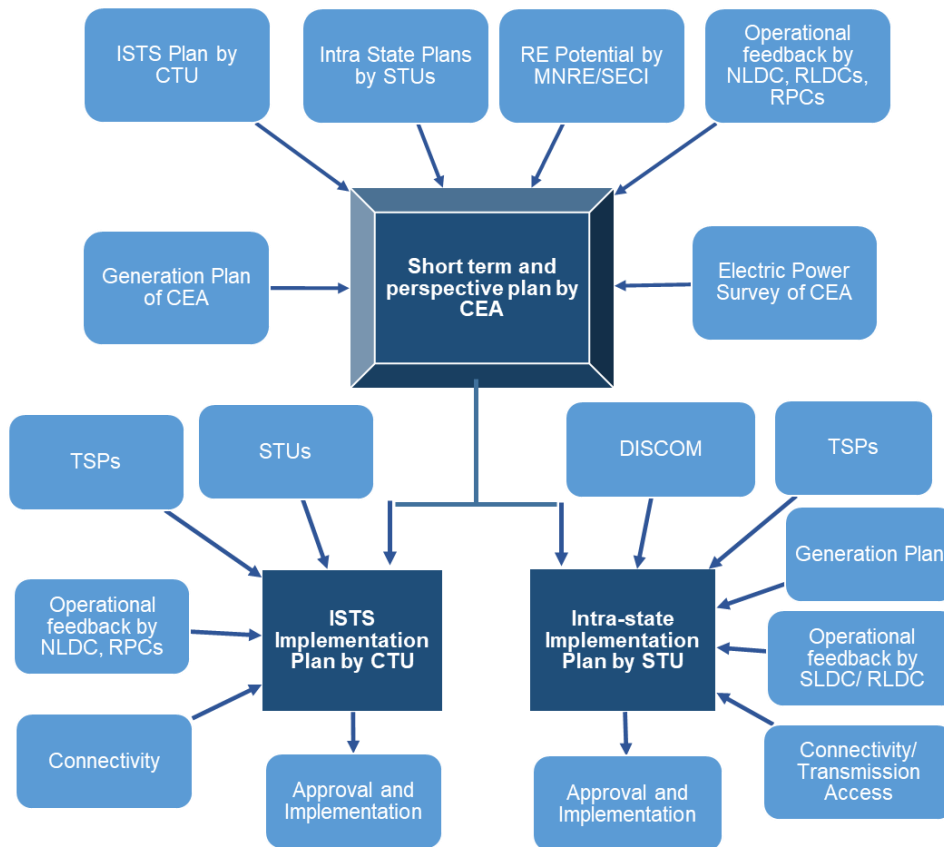
- 7.1.1 CEA shall draw up short term plan every year on rolling basis for up to next five years time horizon and perspective plan every alternate year on rolling basis for next ten years horizon in accordance with Electricity (Transmission System Planning, Development and Recovery of Inter-State Transmission Charges) Rules 2021. While preparation of Short term and perspective plan, CEA shall consult with CTU, STUs, Ministry of New and Renewable Energy (MNRE), RPCs, Solar Energy Corporation of India (SECI), NLDC, RLDCs, generators etc. For perspective plan CEA shall also consult State Governments and Industry Associations. Details of preparation of plans is given in Paragraph 7.2.
- 7.1.2 CTU shall draw up plan for Inter-State Transmission System for up to next five years on rolling basis every year in accordance with Electricity (Transmission System Planning, Development and Recovery of Inter-State Transmission Charges) Rules 2021.
- 7.1.3 For preparing implementation plan of ISTS, Central Transmission Utility (CTU) shall consult the State Transmission Utilities (STUs) , Central Government, State Governments, generating companies, Regional Power Committees (RPCs), Central Electricity Authority (CEA), System Operators, licensees and any other person notified by the Central Government in this behalf. The entities intending to use ISTS shall give their network access requirement well in advance considering time required for implementation of the transmission assets. Details of preparation of implementation plan of ISTS by CTU is given in Paragraph 7.3.
- 7.1.4 STUs shall draw up implementation plan for Intra-state Transmission System in consultation with DISCOMs, generators, system operator and state government. Details of preparation of implementation plan of Intra-state Transmission System by STUs is given in Paragraph 7.4.

The Short-term/perspective/implementation plans shall be prepared considering the provisions of this Manual and other relevant Rules/Regulations.

- 7.1.5 Flow chart of the planning is given below:

---

<sup>3</sup> Inserted vide Amendment-I



## 7.2 Short Term and Perspective Transmission system Plan by CEA

7.2.1 Section 3(4) of the Electricity Act, 2003, provides that the Authority shall prepare a National Electricity Plan in accordance with the National Electricity Policy and notify such plan once in five years. Further, Electricity (Transmission System Planning, Development and Recovery of Inter-State Transmission Charges) Rules, 2021, provides that Central Electricity Authority shall draw up short term plan every year on rolling basis for up to next five years time horizon and perspective plan every alternate year on rolling basis for next ten years time horizon for development of the electricity system and coordinate the activities of the planning agencies for the optimal utilization of resources to sub serve the interests of the National economy and to provide reliable and quality electricity to all consumers.

7.2.2 CEA shall consult relevant stakeholders for preparation of short term and perspective plan and for coordinating the activities of planning agencies through regional standing committees namely Standing Committee on Short Term and Perspective Power System Planning (SCSTPPSP).

7.2.3 Five number of regional standing committees namely “Standing Committee on Short Term and Perspective Power System Planning” one for each region to be constituted to review the existing and under implementation intra-state and

inter-state transmission system in the region, review the operational constraints faced by the system operators in the region, examination of new ISTS proposals and proposals from STUs/Electricity Departments and examine the associated transmission system for generating stations.

7.2.4 Data requirement from various stakeholders for the short term and perspective plan:

- a) Data and information to be provided within CEA: Data related to electricity demand, ISTS and intra-state generation capacity addition/phasing out data, generation plan, and status of on-going transmission system.
- b) Data and information to be provided by CTU: All the planning related data and models in respect of Inter-State Transmission System (ISTS), generating stations connected to ISTS, transmission system requirements, relevant data for connectivity/ General Network Access (GNA) of generation project and drawing entities etc.
- c) Data and information to be provided by STUs (including DVC): All the planning related data and models in respect of Intra-State Transmission System (Intra-STS), transmission system requirements, relevant data for connectivity/ GNA of generation project and drawl entities would be considered
- d) Data and information to be provided by Grid Operator: Information regarding signals of any congestion in any part of the ISTS and Intra-STS in respect of ICT and line loadings, low voltages, over-voltages, extremely high or low fault levels, stability issues, SPS schemes, islanding schemes etc. Historical data of ICT and line loadings, bus voltages, generation and demand profile etc. Any long term issue with in operation of HVDC at rated capacity and both directions i.e. forward and reverse and restrictions in line loadability limit of commissioned transmission system.
- e) Data and information to be provided by Regional Power Committees (RPCs): Provide operational feedback and facilitate data collection from STUs related to transmission planning and protection coordination etc.
- f) Data and information to be provided by MNRE/SECI: Location of the RE potential along-with quantum of the potential including type of such RE, BESS and Green Hydrogen (GH<sub>2</sub>) Potential (Wind/Solar/Hybrid/BESS/GH<sub>2</sub>), details of offshore wind potential and time-frame in which the above potential is expected to materialize.

7.2.5 In accordance with the above, the procedure to be followed for preparation of short term, and perspective plan by CEA is as given below:

S. No.	Actions	Timelines
1.	Furnishing of data by various stakeholders	by 30 <sup>th</sup> April

2.	Analysis of data, carrying out system studies and preparation of draft report	by 31 <sup>st</sup> July
3.	Time to be given to constituents for comments on draft report and incorporation of additional system, if any	August
4.	Meeting with stakeholders on regional basis	September - October
5.	Incorporation of comments, carrying out studies and preparation of Final Report	30 <sup>th</sup> November
6.	Issue of Final Report	31 <sup>st</sup> December

- 7.2.6 Load-generation scenarios shall be worked out as per the requirements so as to reflect the daily and seasonal variations in electricity demand and generation availability (such as cases for peak, off-peak and other than peak / off-peak hours for different seasons considering low, moderate and high renewable/other generation dispatch).
- 7.2.7 While planning the transmission system, options of upgrading the existing ISTS in place of building new transmission lines (such as increasing the line loading through use of compensation, reconductoring, network re-arrangement, augmentation of transformation capacity etc.) shall be explored for optimally utilizing the existing assets.
- 7.2.8 To avoid bottling up of power, STUs shall also plan and implement their downstream networks along with the evolved inter-state transmission system in similar time-frame.
- 7.2.9 The short term and perspective plan consists of broad inter-state and intra-state transmission system requirement of the country which includes:
- Growth of transmission system in India
  - Transmission system planning philosophy and development process
  - New technologies in transmission system
  - Studies and Analysis
  - Transmission system requirements.

### 7.3 Implementation Plan of ISTS by CTU

- 7.3.1 The Central Transmission Utility shall draw up plan for Inter-State Transmission System for up to next five years on rolling basis every year identifying specific transmission projects which are required to be taken up along with their implementation time lines, considering the plans made by Central Electricity Authority and studying the progress in generation capacity and demand in different parts of the country as well as taking note of General Network Access requests made by Designated Inter-state Customers, any signals of any congestion in any part of the Inter-State Transmission System and difficulties in obtaining right of way for development of transmission corridors. For

preparing this plan, Central Transmission Utility shall consult the State Transmission Utilities, Central Government, State Governments, Central Electricity Authority, Regional Power Committees, generating companies, System Operators, licensees and any other person notified by the Central Government in this behalf.

- 7.3.2 The principle for planning of the Inter-State Transmission System shall be to ensure that it is available as per the requirements of the stakeholders, as reflected by their Connectivity and General Network Access requests. The transmission system shall be planned and developed matching with the growth of generation and load, as far as possible, and while doing the planning, care shall be taken that best possible techno-economical alternative is taken up for implementation.
- 7.3.3 CTU shall be the nodal agency for compilation of data required for formulation of basic network data file (base case files) for the purpose of ISTS planning.
- 7.3.4 Data requirement from various stakeholders
- a) Data and information to be provided by CEA: Short term and perspective plan for development of the transmission system.
  - b) Data and information to be provided by STUs (including DVC): All the planning related data and models in respect of Intra-State Transmission System (Intra-STTS), generating stations connected to Intra-STTS etc.
  - c) Data and information to be provided by Generators: Generators connected or intending to connect to ISTS shall submit their technical data including validated models in a comprehensive manner.
  - d) Data and information to be provided by ISTS Transmission Licensees: Steady state and dynamic data pertaining to transmission line, substation equipment, HVDC, FACTS etc.
  - e) Data and information to be provided by Regional/National Load Despatch Centre: Information regarding signals of any congestion in any part of the ISTS in respect of ICT and line loadings, low voltages, over-voltages, extremely low or high fault levels, stability issues etc and historical data of ICT and line loadings, bus voltages, generation and demand profile etc. Any long term issue in operation of HVDC at rated capacity and both directions i.e. forward and reverse and restrictions in line loadability limit of the commissioned transmission system.
  - f) Data and information to be provided by Regional Power Committees (RPCs): Provide operational feedback and facilitate data collection from STUs related to transmission planning and protection coordination etc.
  - g) Data and information to be provided by MNRE: Location of the RE potential (Wind/Solar/Hybrid/BESS/GH<sub>2</sub>) along-with quantum and timeframe, details



of offshore wind potential, demand potential on account of Green Hydrogen/Ammonia production facilities etc.

- h) Data from Applications of Connectivity / General Network Access:  
Applications for grant of Connectivity or grant of GNA.

### 7.3.5 Planning Timelines:

The entire process for transmission planning shall be undertaken on continuous basis, involving two cycles in a year i.e. from April to September (interim) and October to March (final). The ISTS Planning cycle is tabulated below:

Sl. No.	Activity	Concerned entity	1 <sup>st</sup> cycle: Apr-Sep	2 <sup>nd</sup> cycle: Oct-March
1.	Data Collection by CTU:			
	<ul style="list-style-type: none"> <li>Inputs regarding plans made by CEA (short term and perspective plans for next ten years)</li> </ul>	MNRE, CTU, CEA, STUs, RPCs, and GRID INDIA	01 <sup>st</sup> to 30 <sup>th</sup> April	01 <sup>st</sup> to 31 <sup>st</sup> October
	<ul style="list-style-type: none"> <li>Open Access / General Network Access / Cross border transaction requests made by Designated Inter- state Customers / other entities</li> </ul>			
	<ul style="list-style-type: none"> <li>Data to be submitted by the STUs (to be facilitated - by RPCs)</li> </ul>			
	<ul style="list-style-type: none"> <li>Transmission constraints along with operational data to be submitted by System Operators to CTU</li> </ul>			
	<ul style="list-style-type: none"> <li>RE related inputs to be provided by MNRE</li> </ul>			
2.	Data validation and preparation of Load-Generation Balance (LGBs) Scenarios at All India level for different scenarios through joint consultation in separate regional meetings	CTU, CEA, STUs, RPCs, and GRID INDIA	15 <sup>th</sup> June	15 <sup>th</sup> December
3.	Preparation of base case files for identified LGB(s) at All India level	CTU	30 <sup>th</sup> June	31 <sup>st</sup> December
4.	Single or Multi Regional Joint System studies for evolution of new ISTS schemes and / or augmentation of existing system	CTU, CEA, GRID INDIA, and concerned RPC(s) & STU(s)	31 <sup>st</sup> July	31 <sup>st</sup> January

5.	Preliminary proposal along with assumptions on CTU website for stakeholders' comments	CTU	15 <sup>th</sup> August	15 <sup>th</sup> February
6.	Final Report		30 <sup>th</sup> September	31 <sup>st</sup> March

7.3.6 The report shall comprise of power supply scenario, load generation balance, measures taken to mitigate the envisaged issues in the grid, system studies and analysis, ISTS scheme etc.

## 7.4 Implementation plan of Intra-State Transmission System by STU

7.4.1 As per Section 39 of the Electricity Act, 2003, State Transmission Utility (including DVC) shall be responsible to undertake transmission of electricity through Intra-State transmission system, to discharge all functions of planning and co-ordination relating to intra-State transmission system with Central Transmission Utility, State Governments, generating companies, Regional Power Committees, Authority, licensees, any other person notified by the State Government. STU to ensure development of an efficient, co-ordinated and economical system of intra-State transmission lines for smooth flow of electricity from generating stations to the load centres and to provide non-discriminatory open access to its transmission system.

7.4.2 Based on the perspective plan of Central Electricity Authority, STUs (including DVC) to make their own plan considering Intra-state generation capacity addition/phasing out of transmission system, load growth, operational feedback etc on annual rolling basis.

### 7.4.3 Data requirement

- a) Data and information to be provided by DISCOMS: Node-wise electricity demand data of State with its composition. Details of rooftop solar generation and small hydro/solar/wind generation etc. connected at distribution level.
- b) Data and information to be provided by SLDC/RLDC: Information regarding signals of any congestion in any part of the intra state transmission system in respect of ICT and line loadings, low voltage, over-voltages, fault levels, stability issues etc and historical data of ICT and line loadings, bus voltages, generation and demand profile etc for the purpose of study and analysis.
- c) Data and information to be provided by Intra-STS Transmission Licensees: Steady state and dynamic data pertaining to transmission line, substation equipment, HVDC, FACTS etc.

- d) Data and information to be provided by Bulk Consumers: Anticipated electricity demand data (if any).
- e) Data from Applications of Connectivity/General Network Access: Applications for grant of connectivity or grant of GNA.
- f) Information regarding plan of augmentation of ISTS network in the State: From plan of CEA and CTUIL.

#### 7.4.4 Timelines

S. No.	Actions	Concerned entity	Timelines
1.	Data Collection by STU:		
	<ul style="list-style-type: none"> <li>Inputs regarding plans made by CEA (short term &amp; perspective plans for next ten years) and CTU (implementation plan)</li> </ul>	CEA, CTU	01 <sup>st</sup> to 30 <sup>th</sup> April
	<ul style="list-style-type: none"> <li>Open Access / General Network Access /other entities</li> </ul>	DISCOMS, Generators, Bulk Consumer	
	<ul style="list-style-type: none"> <li>Drawal data, Transmission constraints along with operational data to be submitted by System Operators to STU</li> </ul>	SLDC	
2.	Data validation and preparation of Load-Generation Balances (LGBs) at State level for different scenarios through joint consultation in separate meetings	STU	30 <sup>th</sup> June
3.	Preparation of base case files for identified LGB(s) at State level	STU	
4.	Draft Plan along with assumptions on STU website for stakeholders' comments	STU	15 <sup>th</sup> August
5.	Stakeholders' comments on the preliminary proposal	Stakeholders	31 <sup>st</sup> August
6.	Finalisation of transmission schemes considering comments / suggestions of stakeholders and uploading of the final Plan on STU website	STU	30 <sup>th</sup> September

- 7.4.5 The implementation plan for intra-state transmission system shall comprise of power supply scenario, load generation balance, system studies and analysis, details of Intra-state transmission scheme, measures taken to mitigate the constraints envisaged in the grid etc.

## 7.5 Approval and Implementation

### 7.5.1 Approval of ISTS Projects: The ISTS projects planned by CTU to be approved as per following provisions.

7.5.1.1 Electricity (Transmission System Planning, Development and Recovery of Inter-State Transmission Charges) Rules, 2021 provides that “3(5) *The Inter-State Transmission System projects drawn up by Central Transmission Utility shall be placed before the National Committee on Transmission constituted by the Central Government and the National Committee on Transmission shall also include a nominee of each Regional Power Committee. The projects along with their timeline for implementation shall be approved by the Central Government after considering the recommendations of the National Committee on Transmission; Provided that the Central Government may approve any transmission project as deemed necessary from the system or strategic point of view, without waiting for the recommendation of the National Committee on Transmission.*”

7.5.1.2 Ministry of Power, Govt. of India vide office order dated 28<sup>th</sup> October, 2021 has revised the Terms of Reference (TOR) for National Committee on Transmission. As per the point No. 2 (viii) of amended terms of reference:

*“The NCT shall recommend to Ministry of Power (MoP) for implementation of the ISTS projects with cost more than Rs 500 crore, along with their mode of implementation i.e. Tariff Based Competitive Bidding (TBCB) / Regulated Tariff Mechanism (RTM), as per the existing Tariff Policy. However, the NCT shall approve the ISTS costing between Rs 100 crore to Rs.500 crore or such limit as prescribed by MoP from time to time, along with their mode of implementation under intimation to MoP. The ISTS costing less than or equal to Rs. 100 crores, or such limit as prescribed by MoP from time to time, will be approved by the CTUIL along with their mode of implementation under intimation to the NCT and MoP. After approval of the ISTS by the NCT or the CTU (as the case may be), the TBCB project shall be allocated to Bid Process Coordinators through Gazette Notification, while the RTM project shall be allocated to CTU.”*

7.5.1.3 MoP vide letter dated 3<sup>rd</sup> July, 2023 has amended para 2 (ix) of the ToR of NCT as follows:

*“National Committee on Transmission (NCT) will appoint BPCs for all the projects costing more than Rs 100 Crore and will communicate corresponding BPC immediately so that the respective BPCs can start survey work for the particular project”*

### 7.5.2 Implementation of ISTS Project

7.5.2.1 As per National Tariff Policy 2016, while all future inter-state transmission projects shall, ordinarily, be developed through competitive bidding process, the Central Government may give exemption from competitive bidding for

implementation through Regulated Tariff Mechanism (RTM) mode for (a) specific category of projects of strategic importance, technical upgradation etc. or (b) works required to be done to cater to an urgent situation on a case-to-case basis.

The respective approving agencies shall also approve mode of implementation of the transmission project. Further, NCT to finalise Bid Process Coordinators (BPCs) for the transmission schemes to be implemented through Tariff Based Competitive Bidding route. Bidding timelines should be followed as per the standard bidding documents (SBD).

7.5.2.2 The BPCs shall submit the survey report for the transmission schemes within 60 days from the date of NCT meeting. Based on the survey report, implementation timeframe of the scheme shall be worked out.

### 7.5.3 Approval and Implementation of Intra-State Project

7.5.3.1 In regard to implementation of intra-state transmission system, the Tariff Policy notified on 28<sup>th</sup> January, 2016 provides that –

*“5.3 The tariff of all new generation and transmission projects of company owned or controlled by the Central Government shall continue to be determined on the basis of competitive bidding as per the Tariff Policy notified on 6<sup>th</sup> January, 2006 unless otherwise specified by the Central Government on case to case basis.*

*Further, intra-state transmission projects shall be developed by State Government through competitive bidding process for projects costing above a threshold limit which shall be decided by the SERCs.”*

7.5.3.2 STU shall plan and implement the Intra-state Transmission Schemes keeping in view the above provisions.

**Annexure- I****Template Data Format for Transmission Planning**

1. STU can provide input as per the format enclosed.
2. Unless specified, all elements specified in the list shall be treated as of STU
3. Data required includes Substations (Bus), Lines and Transformers connected to the Station (Bus), Generations, Loads and shunt MVAR list.
4. Once the existing data is finalized, year wise data may be provided in the format given here with time frame.
5. The bus number shall be a 6 digit number which will be formed as shown in the table below:

Zone/State		Voltage	Unique Bus Number		
D <sub>1</sub>	D <sub>2</sub>	D <sub>3</sub>	D <sub>4</sub>	D <sub>5</sub>	D <sub>6</sub>

For this purpose Zone/State and Voltage level numbering shall be considered as under:

*A. Zone/State numbering schema*

D <sub>1</sub> D <sub>2</sub>	ZONE/STATE	D <sub>1</sub> D <sub>2</sub>	ZONE/STATE
10	CHANDIGARH	34	GOA
11	JAMMU & KASHMIR	35	GUJARAT
12	HIMACHAL PRADESH	36	MADHYA PRADESH
13	PUNJAB	37	MAHARASTRA
14	HARYANA	41	BIHAR
15	DELHI	42	ODISHA
16	RAJASTHAN	44	WEST BENGAL
17	UTTAR PRADESH	47	JHARKHAND
18	LADDAKH	49	SIKKIM
19	UTTARAKHAND	50	ANDHRA PRADESH
21	ASSAM	51	TELANGANA
22	ARUNACHAL PRADESH	52	KARNATAKA
23	MEGHALAYA	53	KERALA
24	NAGALAND	54	TAMILNADU
25	MANIPUR	57	PUDUCHERRY
26	MIZORAM	61	NEPAL
27	TRIPURA	62	BHUTAN
31	CHATTISGARH	63	BANGLADESH
32	DAMAN AND DIU	64	MYANMAR
33	DADRA AND NAGAR HAVELI	65	SRI LANKA

*B. Voltage level numbering schema*

Voltage Level (kV)	D <sub>3</sub>
765	7
400	4
230	2
220	2
132	1
110	1
66	0
33	0
11	0

The code for zone/state may be changed, if required.

6. The code assignment for owner for identification of type of generator based on source of fuel and sector shall be considered as under:

*A. Sector numbering schema*

Number (1 <sup>st</sup> Digit)	Sector	Short Description
1	Central Sector	Cent
2	State Sector	State
3	Central IPP	C-IPP
4	State IPP	S-IPP

*B. Fuel numbering schema*

Number (2 <sup>nd</sup> Digit)	Source of Fuel
1	Coal
2	Hydro
3	Gas
4	Nuclear
5	Wind
6	Solar
7	Hybrid
8	Other

*C. Owner numbering schema*

Owner allocation (Sector + Fuel) for Central Sector	
Owner No.	Owner Description
11	Cent-Coal
12	Cent-Hyd
13	Cent-Gas
14	Cent-Nucl
15	Cent-Wind
16	Cent-Solar
17	Cent-Hyb
18	Cent-oth

Similarly owner allocations to be made for State sector, Central IPP & State IPP

The above codes may be changed, if required.

7. Template Data Format:

- a. Substation (**List-1**): Consists of buses represented in the file along with name and voltage level, availability of Load and injection by generator
- b. Transmission lines (**List-2**): Consists of lines along with names of the substations interconnected by them with line length, and line reactors if any.
- c. Generator connected (**List-3**): Various generating stations of the state modelled in the file along with parameters are given in the list with values like  $P_{max}$ ,  $P_{min}$ ,  $Q_{max}$ ,  $Q_{min}$ ,  $M_{base}$ ,  $R_{source}$ ,  $R_{Tran}$ ,  $X_{source}$  and  $X_{Tran}$
- d. Loads (**List-4**): Loads considered, both P and Q
- e. Shunt (**List-5**): For FIXED bus shunt includes shunt capacitor or bus reactors.
- f. Transformer (**List-6**): Substation Name, from and to bus Volt, Tap Position, Number of transformers, Transformer MVA, % Impedance.
- g. 2-terminal HVDC (LCC) (**List-7**): Rectifier & Inverter Substation Name, Control Mode, Schedule Voltage, Max. & Min. firing angle, Primary Base Voltage, Bridges in series, DC Resistance, Rated Power
- h. 2-terminal HVDC (VSC) (**List-8**): Converter-1&2 Substation Names, Control Mode, losses, Schedule Voltage, AC current, Max & Min Reactive Capability, Rated Power

- i. FACTS & STATCOM (**List-9**): Substation Name, Control Mode, P & Q setpoint,, Size
- j. Switched Shunt (**List-10**): Substation Name, Control Mode, Remote Bus, Step Size.

Similarly, for every year additional element and load – generation may be given in the above format.



**Annexure-I / List-1****Bus Data**

<b>Data as on Month of the Year</b>						
<b>Sl. No. (Define Bus no)</b>	<b>Name of the S/s or bus - Max. 12 characters</b>	<b>Voltage Level (765/400/230/220/132/110/66/33 kV)</b>	<b>Load Bus (Yes/No)</b>	<b>Generator bus (Yes/No)</b>	<b>Remarks (Existing/ Under construction/ Planned)</b>	<b>Year of Commissioning</b>
XXXXXX	AAA	765/400				
XXXXXX	BBB	400/220				
XXXXXX						

## Annexure-I / List-2

Line Data

**Note:** 1) Unit id or circuit id or representative. If circuit id or unit id is 2, it represents 2 unit or line or transformer etc.

2) Unless otherwise specified – Based on conductor configuration and Line voltage, standard parameters will be assumed as per this planning criteria.

Data as on Month of the Year																				
From BUS (Name)	To BUS (Name)	C K T id	Len gth (km)	Line volta ge (kV)	Lin e Ty pe (S/ c or D/c or Mu lti Ckt )	Conduc tor type (e.g. AL59/ ACSR MOOSE / HTLS/Z ebra etc.)	Conduct or Configur ation (Single/T win /Tripple/ Quad/ Hexa)	Design Ambient / Conduct or Tempera ture	Either in actuals or in pu on 100MVA base			in MVA	in MV A		in pu on 100MVA base		in pu on 100MVA base		Remarks (Existing / under construc tion/ planned)	Year of Comm issioni ng
									R in p u	X in p u	B in p u				Rate A (SIL Loadi ng)	Rate B	Rate C	GI		
AAA	BBB	1	291	765	D/c	Zebra	Hexa	45/75	X	X	X	2200	30		XXXX	-2.4	XXXX	-2.4		
									X	X	X	2200	30		XX	(Fixed)	XX	(Switchable)		
AAA	BBB	2	291	765	D/c	Zebra	Hexa		X	X	X	2200	30			-2.4		-2.4		
									X	X	X	2200	30			(Fixed)		(Switchable)		
BBB	CCC	1	208	765	S/c	Bersimis	Quad		X	X	X	2200	30			0		-2.4		
									X	X	X	2200	30					(Switchable)		
DDD	CCC	2	208	765	S/c	Bersimis	Quad		X	X	X	2200	30			0		-2.4		
									X	X	X	2200	30					(Switchable)		
DDD	KKK	1	75	220	D/c	Zebra	Single		X	X	X	130								
									X	X	X	130								
CCC	EEE	2	75	220	D/c	Zebra	Single		X	X	X	130								
									X	X	X	130								
CCC	FFF	1	77	132	D/c	Panther	Single		X	X	X	65								
									X	X	X	65								
GGG	SSS	2	77	132	D/c	Panther	Single		X	X	X	65								
									X	X	X	65								
GGG	CCC	1	44	220	D/c	Zebra	Single		X	X	X	130								
									X	X	X	130								

**Annexure-I / List-3****Generator Data****Note:**

- 1) Unit id or circuit id or representative. If circuit id or unit id is 2, it represents 2 unit or line or transformer etc.
- 2) In case of RE generators, aggregated generation (lumped) at STU/Developer PS may be defined.
- 3) The load shall be adjusted as per season and despatch considered. If already adjusted, it may be mentioned.

Fuel Type	Coal	Hydro	Gas	Nuclear	Wind	Solar	Standalone Storage
ID No format	T, T1 to T9	H, H1 to H9	G, G1 to G9	N, N1 to N9	WF (Wind farms), W1 to W9	SP (Solar Parks), S1 to S9	

State	SOLAR ROOF TOP CAPACITY IN MW			
	By 2022	By 2023	By 2024	By 2025....

RE	RPO Commitment (%)			
	By 2022	By 2023	By 2024	By 2025...
Solar				
Non Solar				

Hydro	HPO Commitment (%)			
	By 2022	By 2023	By 2024	By 2025...
Hydro				

Data as on Month of the Year																			
Bus Name	Voltage Level (kV)	GT voltage rating	GT MVA Rating or PF	Fuel Type	Unit Id	Unit size	Owner (State/Private)	P <sub>max</sub> Gen capacity (MW)	P <sub>min</sub> Technical Min (MW)	Q <sub>Max</sub> (Mvar)	Q <sub>Min</sub> (Mvar)	Mbase (MVA)	R <sub>Source</sub> (pu)	X <sub>Source</sub> (pu)	R <sub>Tran</sub> (pu on machine MVA base) of GT	X <sub>Tran</sub> (pu on machine MVA base) of GT	In Case of RE generation control mode	Power factor	Year of Commissioning
AAA	13	13/220 kV	248	Coal	T1	210	State						0	0.2	0	14.50%			
AAA	13	13/220 kV	248	Coal	T2	210	Private						0	0.2	0	14.50%			
BBB	11	13/220 kV	175	Hydro	H1	155							0	0.32	0	14.50%			
DDD	11	13/220 kV	175	Hydro	H2	155							0	0.32	0	14.50%			
DDD	15	13/220 kV	150	Gas	G1	130							0	0.18	0	14.50%			
CCC	23	15.5/220	249	Nuclear	N1	220							0	0.23		14.50%			
CCC	22			Wind	W1	50										14.50%			
GGG				Solar	S1	200										14.50%			

## Annexure-I / List-4

**Load Data****Note:**

- 1) Quarter wise load can be indicated bus wise or as a percentage of maximum load.
- 2) The load shall be adjusted as per season and despatch considered. If already adjusted it may be mentioned.

Data as on Month of the Year (for 20XX year)					2023-24....		
Bus Name (132kV/110/66/33kV) (Max. 12 character)	Voltage level (220kV / 132kV/ 110kV) Load is connected to	Active Load (MW) (P <sub>max</sub> )	Reactive Load (QL) or Power factor for Peak load case	Reactive Load (QL) or Power factor for off-peak load case	Active Load (MW) (P <sub>max</sub> )	Reactive Load (QL) or Power factor for Peak load case	Reactive Load (QL) or Power factor for off-peak load case
ABC	220	120			130		
DEF	132	85			95		
XYZ	220	150			160		
ABC	220	220			240		

	Roof top solar adjusted YES/NO	2022-23		2023-24		2024-25...	
		Peak	Off-Peak				
<b>Maximum Load</b>							
Quarter-1		80%	50%				
Quarter-2		75%	55%				
Quarter-3		80%	50%				
Quarter-4		80%	50%				

**Annexure-I / List-5****Fixed Shunt Data****Note:**

- 1) Unit id or circuit id or representative. If circuit id or unit id is 2, it represents 2 unit or line or transformer etc.
- 2) Reactors to be shown negative.

Data as on Month of the Year					
S.No.	Bus Name (765kV/400kV/230kV/132kV)	Voltage level (132kV/ 110kV)	Id	MVAR	Year of Commissioning
	ABC	765	1	-240	
	DEF	765	2	-240	
	XYZ	765	1	-240	
	TUV	765	2	-240	
	GHI	132	1	100	
	JKL	220	1	150	
	PQR	132	2	70	
	RST	220	1	253	
	MNO	400	1	-80	
	WXY	400	1	-80	

**Annexure-I / List-6****Transformer/ ICT Data****Note:**

1) Unit id or ckt id or representative. If ckt id or unit id is 2, it represents 2 unit or line or transformer etc.

Data as on Month of the Year										
From BUS No.	To BUS No.	CKT	Voltage level (kV) (to bus no)	No of taps	Voltage change /step	Tap Positions	MVA Rating (Rate A)	Winding MVA Base	% Impedance on transformer base	Year of Commissioning
AAAAA8	AAAAA4	1	765/400	17	1.25%	8	1500	1500	12.50%	
BBBBB8	BBBBB4	1	765/400	17	1.25%	8	1500	1500	12.50%	
CCCCC8	CCCCC4	1	765/400	17	1.25%	8	1500	1500	12.50%	
DDDDD8	DDDDD4	1	765/400	17	1.25%	8	1500	1500	12.50%	
EEEEEE8	EEEEEE4	1	765/400	17	1.25%	8	1500	1500	12.50%	
FFFFF4	FFFFF2	1	400/220	17	1.25%	8	500	1500	12.50%	
GGGGG4	GGGGG2	1	400/220	17	1.25%	8	300	1500	12.50%	
BBBBB1	BBBBB2	1	220/132	17	1.25%	8	100	1500	12.50%	

**Annexure-I / List-7**

**2-TERMINAL HVDC (LCC)**

Data as on Month of the Year															
Line						Converter									Year of Commissioning
Rectifier Bus	Inverter Bus	Control Mode (Blocked, Power, Current)	Set Val (Amp or MW)	Rdc (Ohm)	Schedule Voltage (kV)	Max. Firing angle (deg)	Min. Firing angle (deg)	Bridges in series (nos.)	Primary Base (kV)	Commutating Resistance	Commutating Reactance	Tap setting (pu)	Max. Tap setting	Min. Tap setting	
AAAAA8	AAAAA4	Power	1000	10.7	500	17.5	12.5	2	400	0.3	7.8	1.03	1.2	0.85	
BBBBB8	BBBBB4														



**Annexure-I / List-8**

**2-TERMINAL HVDC (VSC)**

Data as on Month of the Year												
Converter Bus -1	Converter Bus -2	Control Mode (Blocked / Power/ Voltage)	Set Val (kV or MW)	Rdc (Oh m)	A loss (kW)	B loss (kW/ Amp)	Schedule Voltage (kV)	AC Current rating (amp)	Max. Reactive Power (MVar)	Min. Reactive Power (MVar)	RMPCT (%)	Year of Commissioning
AAAAA8	AAAAA4	Power	1000	10.7	5000	2.5	500	3300	2000	-2000	50	
BBBBB8	BBBBB4											

**Annexure-I / List-9**

**STATCOM**

Data as on Month of the Year													
Bus Number	Control Mode (Blocked, Normal)	P set point (MW)	Q Set point (MVAr)	V send Set point	Shunt Max (MVA)	RMPCT (%)	Bridge Max (MW)	V Term Max (pu)	V Term Min (pu)	V series Max (pu)	I series Max (pu)	Dummy series X(pu)	Year of Commissioning
AAAAA8	Power												
BBBBB8													

**Annexure-I / List-10**

**Switched Shunt**

Data as on Month of the Year													
Bus Number	Control Mode (Locked, Continuous Cntrl Voltage, Cntrl Plant MVar)	Vhi (pu)	Vlo (pu)	Remote Bus	RMPCT (%)	B init (MVar)	Blk 1 Steps	Blk 1 B step (Mvar)	Blk 2 Steps	Blk 2 B step (Mvar)	Blk 3 Steps	Blk 3 B step (Mvar)	Year of Commissioning
AAAAA8	Power												
BBBBB8													

## Annexure- II

**DATA FOR TRANSMISSION PLANNING STUDIES****Table- I(a)****(Line parameters (per unit / km / circuit, at 100 MVA base))**

Actual system data based on actual tower dimensions, wherever available, should be used. In cases where data is not available standard data given below can be assumed:

Voltage (kV)	Config.	Type of conductor	Ckt	Positive sequence			Zero sequence		
				R	X	B	R <sub>0</sub>	X <sub>0</sub>	B <sub>0</sub>
765	Quad	@ACSR Bersimis	S/C	1.951E-6	4.880E-5	2.35E-2	4.500E-5	1.800E-4	1.406E-2
	Hexa	@ACSR Zebra	D/C	2.096E-6	4.360E-5	2.66E-2	3.839E-5	1.576E-4	1.613E-2
	Hexa	#ACSR Zebra	D/C	2.076E-6	4.338E-5	2.675E-2	3.662E-5	1.582E-4	1.605E-2
	Hexa	#AL59 (61/3.08)	D/C	2.056E-6	4.351E-5	2.671E-2	3.660E-5	1.583E-4	1.609E-2
400	Twin	ACSR Moose	S/C	1.862E-5	2.075E-4	5.55E-3	1.012E-4	7.750E-4	3.584E-3
	Twin	ACSR Moose	D/C	1.800E-5	1.923E-4	6.02E-3	1.672E-4	6.711E-4	3.669E-3
	Twin	AL59 (61/3.31)	D/C	1.871E-5	1.946E-4	5.980E-3	1.556E-4	6.777E-4	3.650E-3
	Twin	ACSR Lapwing	S/C	1.230E-5	1.910E-4	6.08E-3	6.685E-5	7.134E-4	3.926E-3
	Twin	ACSR Lapwing	D/C	1.204E-5	1.905E-4	6.08E-3	1.606E-4	6.651E-4	3.682E-3
	Twin	Moose eq. AAAC	S/C	1.934E-5	2.065E-4	5.67E-3	1.051E-4	7.730E-4	3.660E-3
	Triple	ACSR Zebra	S/C	1.401E-5	1.870E-4	5.86E-3	7.616E-3	6.949E-4	3.783E-3
	Triple	ACSR Snowbird	D/C	1.193E-5	1.721E-4	6.733E-3	1.477E-3	6.499E-4	3.950E-3
	Quad	ACSR Zebra	S/C	1.050E-5	1.590E-4	6.60E-3	5.708E-3	5.940E-4	4.294E-3
	Quad	ACSR Bersimis	S/C	7.416E-6	1.560E-4	7.46E-3	4.031E-3	5.828E-4	4.854E-3
	Quad	ACSR Moose	S/C	9.167E-6	1.580E-4	7.32E-3	1.550E-4	6.250E-4	4.220E-3
	Quad	ACSR Moose	D/C	9.177E-6	1.582E-4	7.33E-3	1.557E-4	6.246E-4	4.237E-3
	Quad	AL59 (61/3.31)	D/C	9.506E-6	1.594E-4	7.299E-3	1.439E-4	6.318E-4	4.221E-3
	Quad	Moose eq. AAAC	S/C	9.790E-6	1.676E-4	6.99E-3	5.320E-3	6.260E-4	4.510E-3

Voltage (kV)	Config.	Type of conductor	Ckt	Positive sequence			Zero sequence		
				R	X	B	R <sub>0</sub>	X <sub>0</sub>	B <sub>0</sub>
220	Twin	ACSR Moose <sup>4</sup>	S/C	4.304E-5	5.819E-4	1.98E-3	4.200E-4	2.414E-3	1.107E-3
	Single	ACSR Zebra	S/C	1.440E-4	8.220E-4	1.41E-3	4.231E-4	2.757E-3	8.843E-4
	Single	ACSR Drake	S/C	1.800E-4	8.220E-4	1.41E-3	6.1E-4	2.56E-3	8.050E-4
	Single	ACSR Moose	S/C	1.547E-4	8.249E-4	1.42E-3	4.545E-4	2.767E-3	8.906E-4
	Single	ACSR Kunda	S/C	1.547E-4	8.249E-4	1.42E-3	4.545E-4	2.767E-3	8.906E-4
	Single	AAAC Zebra	S/C	1.547E-4	8.249E-4	1.42E-3	4.545E-4	2.767E-3	8.906E-4
	Single	ACSR Zebra	D/C	1.416E-4	8.227E-4	1.407E-3	5.398E-4	2.676E-3	8.869E-4
	Single	ACSR Moose	D/C	1.152E-4	8.078E-4	1.433E-3	5.137E-4	2.661E-3	9.074E-4
	Twin	ACSR Zebra	D/C	7.049E-5	5.842E-4	2.006E-3	4.692E-4	2.437E-3	1.132E-3
	Twin	ACSR Moose	D/C	5.772E-5	5.767E-4	2.003E-3	4.563E-4	2.429E-3	1.118E-3
	Twin	AL59 ZEBRA	D/C	7.027E-5	5.885E-4	1.973E-3	4.672E-4	2.442E-3	1.118E-3
Twin	AL59 Moose	D/C	6.132E-5	5.851E-4	1.990E-3	4.583E-4	2.438E-3	1.127E-3	
132	Single	ACSR PANTHER <sup>5</sup>	S/C	9.310E-4	2.216E-3	5.10E-4	2.328E-3	9.310E-3	
	Single	ACSR PANTHER	D/C	7.823E-4	2.323E-3	4.950E-4	1.957E-4	7.606E-3	3.138E-4
66	Single	ACSR DOG <sup>6</sup>	S/C	3.724E-3	8.864E-3	1.28E-4			
	Single	ACSR DOG	D/C	6.299E-3	1.024E-2	1.242E-4	1.103E-2	3.305E-2	8.171E-5

@: With 15m ground clearance

#: With 18m ground clearance

<sup>4</sup> Inserted vide Amendment-I

<sup>5</sup> Inserted vide Amendment-I

<sup>6</sup> Inserted vide Amendment-I

**Table- I(b)**

The resistance data (in  $\Omega/\text{km}$ ) for **Zebra conductor equivalent** size is given in following Table. The reactance(X) and susceptance (B) values of line mainly depend on the tower configuration, and therefore the X and B values (in per unit / km / circuit) may be taken from Table I(a) above for similar configuration.

Name of Conductor	Stranding/wire diameter (mm)		Overall diameter (mm)	DC Resistance ( $\Omega/\text{km}$ )	AC Resistance values at different temperatures (in $\Omega/\text{km}$ )			
	Al/Al alloy wire	steel wire			20° C	75 ° C	85 ° C	95 ° C
ACSR	54/3.18	7/3.18	28.62	0.06868	0.08686	0.08968	NA	
AAAC	61/3.19	NA	28.71	0.06819	0.08269	0.08511	0.08754	
AL59	61/3.08	NA	27.72	0.06530	0.07998	0.08243	0.08488	

**Table- I(c)**

The resistance data (in  $\Omega/\text{km}$ ) for **Bersimis conductor equivalent** size is given in following Table. The reactance(X) and susceptance (B) values of line mainly depend on the tower configuration, and therefore the X and B values (in per unit / km / circuit) may be taken from Table I(a) above for similar configuration.

Name of Conductor	Stranding/wire diameter (mm)		Overall diameter (mm)	DC Resistance ( $\Omega/\text{km}$ )	AC Resistance values at different temperatures (in $\Omega/\text{km}$ )			
	Al/Al alloy wire	steel wire			20° C	75 ° C	85 ° C	95 ° C
ACSR	42/4.57	7/2.54	35.04	0.04242	0.05451	0.05622	NA	
AAAC	61/4.0	NA	36.00	0.04337	0.05350	0.05502	0.05654	
AL59	61/4.02	NA	36.18	0.03840	0.04814	0.04955	0.05097	

**Table- I(d)**

The resistance data (in  $\Omega/\text{km}$ ) for **Moose conductor equivalent** size is given in following Table. The reactance(X) and susceptance (B) values of line mainly depend on the tower configuration, and therefore the X and B values (in per unit / km / circuit) may be taken from Table I(a) above for similar configuration.

Name of Conductor	Stranding/wire diameter (mm)		Overall diameter (mm)	DC Resistance ( $\Omega/\text{km}$ )	AC Resistance values at different temperatures ( $\Omega/\text{km}$ )			
	Al/Al alloy wire	steel wire			20° C	75 ° C	85 ° C	95 ° C
ACSR	54/3.53	7/3.53	31.77	0.05552	0.07046	0.07273	NA	
AAAC	61/3.55	NA	31.95	0.05506	0.06719	0.06914	0.07109	
AL59	61/3.52	NA	31.70	0.0501	0.06190	0.06377	0.06564	
AL59	61/3.31	NA	29.79	0.0566	0.06961	0.07173	0.07385	

**Table- I(e)**

The resistance data (in  $\Omega/\text{km}$ ) for **Panther conductor equivalent** size is given in following Table. The reactance(X) and susceptance (B) values of line mainly depend on the tower configuration, and therefore the X and B values (in per unit / km / circuit) may be taken from Table I(a) above for similar configuration.

Name of Conductor	Stranding/wire diameter (mm)		Overall diameter (mm)	DC Resistance ( $\Omega/\text{km}$ )	AC Resistance values at different temperatures ( $\Omega/\text{km}$ )		
	Al/Al alloy wire	steel wire			20° C	75 ° C	85 ° C
ACSR	30/3.0	7/3.0	21.00	0.1390	0.17029	0.17586	NA
AAAC	37/3.15	NA	22.05	0.1151	0.13848	0.14261	0.14674
AL59	37/3.08	NA	21.56	0.1075	0.13060	0.13466	0.13873

**Table- I(f)**

Name of Conductor	Stranding/wire diameter (mm)		Overall diameter (mm)	DC Resistance ( $\Omega/\text{km}$ )	AC Resistance values at different temperatures ( $\Omega/\text{km}$ )		
	Al wire	steel wire			20° C	75 ° C	85 ° C
ACSR Snowbird	42/3.99	7/2.21	30.57	0.05516	0.07024	0.07248	NA
ACSR Lapwing	45/4.78	7/3.18	38.22	0.0358	0.04632	0.04775	NA

**Note:**

ACSR - Aluminum Conductor Steel Reinforced

AAAC - All Aluminum Alloy Conductor, corresponding to 53.0% of IACS (based on IEC standard)

AL 59 - High conductivity Aluminium Alloy Conductor as per IS-398, Part-6

Any conductor other than above shall be as per IS 398. In case Indian Standards is not available for the same, IEC/ IEEE or equivalent international Standards and codes shall be followed.

**Table- I(g)****Single core XLPE Copper Cable**

Voltage level	Cross Section area of conductor (Sq. mm.)	Max. DC resistance @ 20 deg C (ohm/Km)	Max. AC resistance @ 90 deg C (ohm/km)	Max. Electrostatic capacitance (microfarads /km)	Approx. Current carrying capacity Laid direct in ground at 30 deg C (A)	Approx. Current carrying capacity in air at 40 deg C ambient (A)
132 kV	800	0.022	0.032	0.22	725	1190
220 kV	2500	0.007	0.013	0.27	1315	2290

Note: These are indicative values which may vary as per laying condition and cable design etc.

**Table- II****(Thermal Loading Limits of Transmission Lines)**

Actual system data, wherever available, should be used. In cases where data is not available standard data given below can be assumed. Data for some new conductors which are equivalent to ACSR Zebra/Bersimis/Moose/Panther/Snowbird/Lapwing are also given in following tables:

**Thermal Loading Limits for ACSR Zebra equivalent Conductors:**

Name of Conductor	Stranding/wire diameter (mm)		Ambient Temperature (°C)	Ampacity for Maximum Conductor Temperature (°C)			
	Al/Al alloy wire	steel wire		65 ° C	75 ° C	85 ° C	95 ° C
ACSR Zebra	54/3.18	7/3.18	40	451	626	756	NA
			45	328	546	694	NA
			48	222	492	654	NA
			50	103	453	625	NA
AAAC	61/3.19	NA	40	461	642	776	887
			45	335	560	713	834
			48	227	505	671	800
			50	104	464	642	776
AL59	61/3.08	NA	40	469	649	783	894
			45	343	567	719	840
			48	237	512	678	806
			50	123	471	648	782

**Thermal Loading Limits for ACSR Bersimis equivalent Conductors:**

Name of Conductor	Stranding/wire diameter (mm)		Ambient Temperature (°C)	Ampacity for Maximum Conductor Temperature (°C)			
	Al/Al alloy wire	steel wire		65 ° C	75 ° C	85 ° C	95 ° C
ACSR Bersimis	42/4.57	7/2.54	40	569	816	997	NA
			45	389	706	912	NA
			48	217	630	856	NA
			50	NA	574	817	NA
AAAC	61/4.0	NA	40	573	827	1013	1166
			45	387	714	926	1093
			48	206	637	870	1047
			50	NA	580	830	1015



AL59	61/4.02	NA	40	604	872	1069	1229
			45	408	754	977	1153
			48	215	672	917	1104
			50	NA	611	875	1070

**Thermal Loading Limits for ACSR Moose equivalent Conductors:**

Name of Conductor	Stranding/wire diameter (mm)		Ambient Temperature (°C)	Ampacity for Maximum Conductor Temperature (°C)			
	Al/Al alloy wire	steel wire		65 ° C	75 ° C	85 ° C	95 ° C
ACSR Moose	54/3.53	7/3.53	40	501	707	858	NA
			45	354	614	787	NA
			48	222	551	740	NA
			50	NA	504	707	NA
AAAC	61/3.55	NA	40	512	724	881	1010
			45	361	629	808	948
			48	225	565	760	909
			50	NA	517	726	882
AL59	61/3.52	NA	40	534	754	916	1049
			45	377	655	840	985
			48	237	588	790	944
			50	NA	538	755	916
AL59	61/3.31	NA	40	503	703	852	975
			45	362	613	782	916
			48	239	552	736	878
			50	88	507	704	852

**Thermal Loading Limits for ACSR Panther equivalent Conductors:**

Name of Conductor	Stranding/wire diameter (mm)		Ambient Temperature (°C)	Ampacity for Maximum Conductor Temperature (°C)			
	Al/Al alloy wire	steel wire		65 ° C	75 ° C	85 ° C	95 ° C
ACSR Panther	30/3.0	7/3.0	40	317	424	505	NA
			45	244	374	465	NA
			48	187	341	440	NA
			50	136	317	422	NA
AAAC	37/3.15	NA	40	352	474	566	643
			45	269	418	522	605
			48	204	380	493	582
			50	144	353	473	565

Name of Conductor	Stranding/wire diameter (mm)		Ambient Temperature (°C)	Ampacity for Maximum Conductor Temperature (°C)			
	Al/Al alloy wire	steel wire		65 ° C	75 ° C	85 ° C	95 ° C
AL59	37/3.08	NA	40	362	486	580	658
			45	278	429	535	619
			48	212	390	505	595
			50	152	362	485	578

### **Thermal Loading Limits for following ACSR Conductors**

Name of Conductor	Stranding/wire diameter (mm)		Ambient Temperature (°C)	Ampacity for Maximum Conductor Temperature (°C)			
	Al wire	steel wire		65 ° C	75 ° C	85 ° C	95 ° C
ACSR Snowbird	42/3.99	7/2.21	40	502	703	853	NA
			45	358	613	782	NA
			48	232	550	736	NA
			50	63	505	703	NA
ACSR Lapwing	45/4.78	7/3.18	40	615	896	1101	NA
			45	405	772	1006	NA
			48	187	686	944	NA
			50	NA	622	899	NA

The above data has been calculated based on following assumptions:

- Elevation above sea level = 0 m
- Solar radiations = 1045 W/m<sup>2</sup>.
- Wind velocity considering angle between wind & axis of conductor as 90 degrees = 0.56 m/sec
- Solar Absorption Coefficient = 0.8
- Emissivity Coefficient = 0.45
- Effective angle of incidence of sun's rays= 90 deg

Note: Generally, the ambient temperature may be taken as 45 deg Celsius; however, in some areas like hilly areas where ambient temperatures are less, the same may be taken after due calculation given in IS-9676.

### **High Temperature Low Sag conductors (HTLS)**

HTLS conductors are capable of being operated continuously at temperatures as high as 250° C without any degradation in mechanical or electrical properties. However, in such conductors, the increase in sag is not linear at all temperatures because above a certain temperature called 'knee point temperature', the conductor experiences a sag increase due to the expansion of core alone (coefficient of linear expansion of

core wires are comparatively lower than the complete conductor). This is because of the higher thermal expansion rate of aluminium which causes all the stress of the conductor to be borne by the core beyond the knee point temperature. Therefore, beyond the knee point temperature, the new expansion coefficient of the conductor will be the same as that of the core, resulting in relatively low sag increase when operated at high temperature.

Indicative parameters of HTLS conductor:

Transmission Line	Ampacity of HTLS per conductor	Minimum Conductor diameter (mm)	Maximum DC Resistance at 20°C (Ω/km)	Sub-conductor Spacing (mm)
400 kV Transmission line with Twin HTLS conductor	----- A*	28.62	0.05552	450
220 kV transmission line with single HTLS conductor	-----A*	25	0.06868	NA

\*Ampacity shall be decided based on actual MVA capacity of circuit.

Some of the common types of HTLS conductors are as follows:

1. Aluminium Conductor Steel Supported Conductor
2. INVAR Conductor
3. GAP Conductor
4. Composite core Conductor

Note: Any new technology can be adopted which follows any National/International standard for design, safety and corresponding testing.

**Table- III**  
**(Transformer Reactance)**

Actual system data, wherever available, should be used. In cases where data is not available standard data given below can be assumed:

Type of Transformer	Transformer reactance $X_t$ (at its own base MVA)
Generator transformer (GT)	14 – 15 %
Inter-Connecting Transformer (ICT)	12.5 % (for 400 kV and below) 14% (for 765 kV)

**Data for Transient Stability Studies****Table- IV****(Voltage and Frequency Dependency of Load)**

Actual system data, wherever available, should be used. In cases where data is not available standard data given below can be assumed:

Load	Voltage Dependency of the system loads	Frequency Dependency of the system loads
Active loads (P)	$P = P_0 \left( \frac{V}{V_0} \right)$	$P = P_0 \left( \frac{f}{f_0} \right)$
Reactive loads (Q)	$Q = Q_0 \left( \frac{V}{V_0} \right)^2$	Q can be taken as independent of frequency. However, if appropriate relationship is known, Q may also be simulated as dependent on frequency, on case to case basis.
(where $P_0$ , $Q_0$ , $V_0$ and $f_0$ are values at the initial system operating conditions)		

**Table- V****(Modelling for Machines)**

Actual system data, wherever available, should be used. In cases where data is not available standard data given below can be assumed:

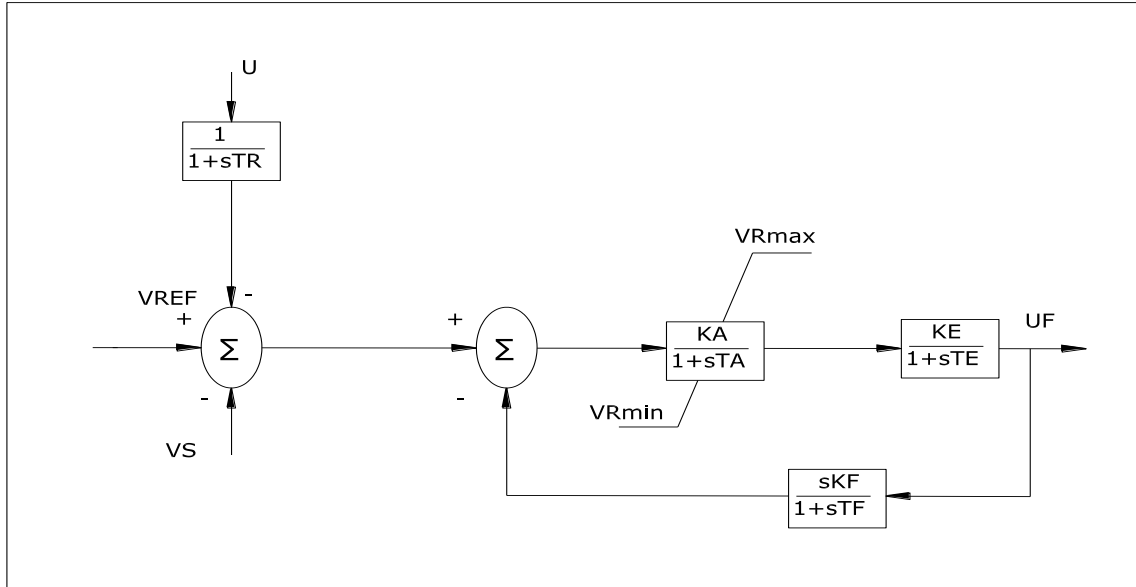
**Table- V(a) : 'Typical parameters for Thermal and Hydro Machines'**

MACHINE PARAMETERS	MACHINE RATING (MW)				
	THERMAL				HYDRO
	800 (Mundra)	660 (Sipat-I)	500 (Simhadri-II)	210	200
Rated Voltage (kV)	26.00	24.00	21.00	15.75	13.80
Rated MVA	960.00	776.50	588.00	247.00	225.00
Inertia Constant (H)	4.50	4.05	4.05	2.73	3.50
<b>Reactance</b>					
Leakage ( $X_L$ )	0.18	0.188	0.147	0.18	0.16
Direct axis ( $X_d$ )	2.07	2.00	2.31	2.23	0.96
Quadrature axis ( $X_q$ )	2.04	1.89	2.19	2.11	0.65
<b>Transient Reactance</b>					
Direct axis ( $X'_d$ )	0.327	0.265	0.253	0.27	0.27
Quadrature axis ( $X'_q$ )	0.472	0.345	0.665	0.53	0.65

MACHINE PARAMETERS	MACHINE RATING (MW)				
	THERMAL				HYDRO
	800 (Mundra)	660 (Sipat-I)	500 (Simhadri-II)	210	200
<b>Sub-transient Reactance</b>					
Direct axis ( $X''_d$ )	0.236	0.235	0.191	0.214	0.18
Quadrature axis ( $X''_q$ )	0.236	0.235	0.233	0.245	0.23
<b>Open Circuit Time Const.</b>					
<b>Transient</b>					
Direct axis ( $T'_{do}$ )	8.60	6.20	9.14	7.00	9.70
Quadrature axis ( $T'_{qo}$ )	1.80	2.50	2.50	2.50	0.50
<b>Sub-transient</b>					
Direct axis ( $T''_{do}$ )	0.033	0.037	0.04	0.04	0.05
Quadrature axis ( $T''_{qo}$ )	0.05	0.20	0.20	0.20	0.10

Table: V(b) - 'Typical parameters for Exciters'

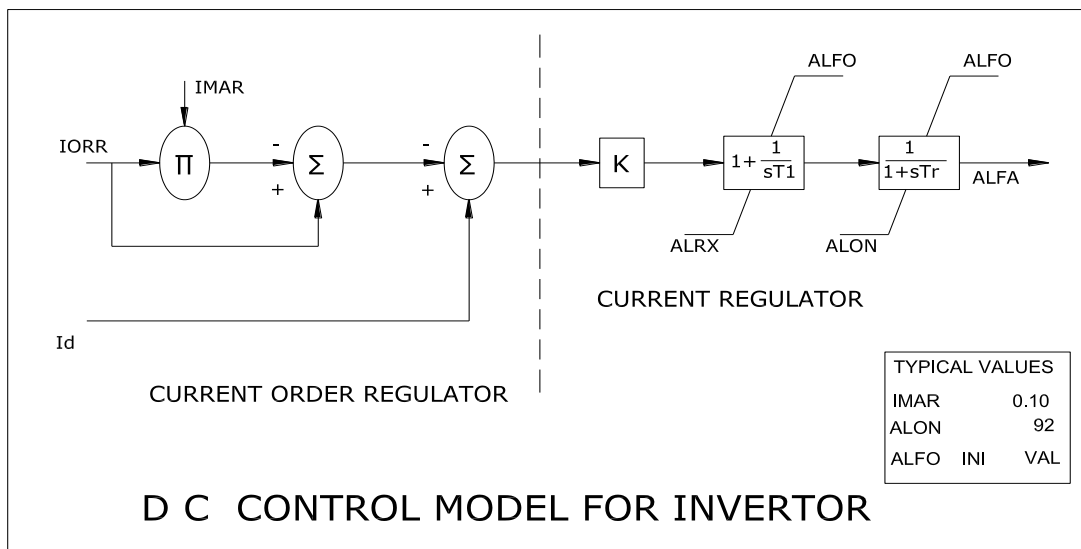
Typical Parameters	Hydro	Thermal	
		< 210 MW	> 210 MW
Transdu. Time Const. (TR)	0.040	0.040	0.015
Amplifier gain (KA)	25 – 50	25 – 50	50 -200
Amplif. Time Const.(TA)	0.04 – 0.05	0.04 – 0.05	0.03 – 0.05
<b>Regulator limiting voltage</b>			
Maximum ( $V_{R_{max}}$ )	4.0	6.0	5.0
Minimum ( $V_{R_{min}}$ )	-4.0	-5.0	-5.0
<b>Feedback signal</b>			
Gain (KF)	0.01	0.01	0.01
Time Constant (TF)	1.00	1.00	1.00
<b>Exciter</b>			
Gain(KE)	1.0	1.00	1.00
Time Constant (TE)	0.7	0.3	0.3

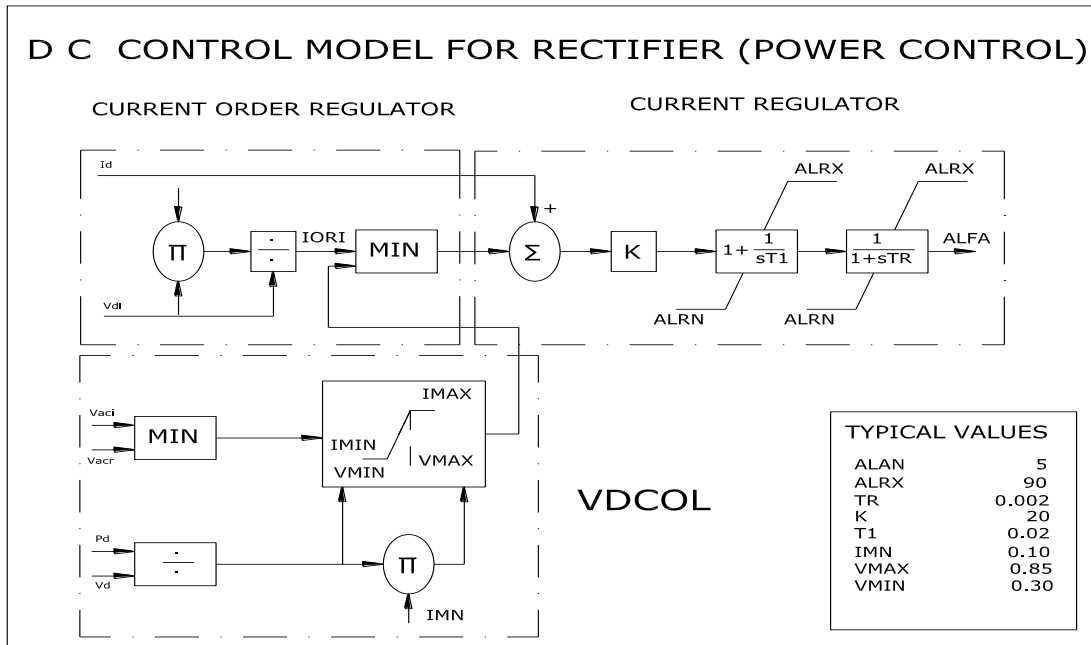


**Table- VI**  
**(Modeling for HVDC)**

Actual system data, wherever available, should be used. In cases where data is not available standard data given below can be assumed:

**HVDC Data:** No standardized DC control model has been developed so far as this model is usually built to the load requirements of the DC terminals. Based on the past experience in carrying out stability studies, the following models are suggested for Rectifier and Inverter terminals.





**Annexure- III**

**Table-I**  
**(Load Factors)**

To replicate and simulate seasonal power requirement variations on annual basis, three load-generation scenarios within a day in three different seasons may be chosen. Three points on load curves were identified for each day i.e. Day Peak load (Solar max i.e. afternoon), Evening Peak load and Night off-peak load. Further, the same was carried out for three seasons viz. Monsoon, Summer and Winter. Accordingly, load factors are prepared as below:

Season	Monsoon			Summer			Winter		
Scenarios	Day Peak	Evening Peak	Night off-Peak	Day Peak	Evening Peak	Night off-Peak	Day Peak	Evening Peak	Night off-Peak
Region	%	%	%	%	%	%	%	%	%
All India	83%	89%	78%	91%	100%	86%	90%	87%	69%
NR	82%	88%	80%	88%	104%	86%	70%	74%	46%
WR	76%	80%	70%	89%	90%	83%	99%	86%	70%
SR	74%	76%	63%	80%	85%	71%	94%	86%	70%
ER	83%	97%	88%	84%	99%	84%	69%	81%	54%
NER	69%	93%	72%	64%	83%	62%	55%	79%	42%

Note: The above factors may be revised from time to time.

**Table-II**  
**(Capacity Factors – for Renewable Energy Source (wind/solar) generation)**

Capacity factor, considering diversity in wind/solar generation, is the ratio of maximum generation available at an aggregation point to the algebraic sum of capacity of each wind machine / solar panel connected to that grid point. Actual data, wherever available, should be used. In cases where data is not available the Capacity factor (in %) may be calculated using following factors:

**Table-II(a)**  
**Capacity Factor for Solar Generation**

Season	Monsoon			Summer			Winter		
Scenarios	Day Peak	Evening Peak	Night off-Peak	Day Peak	Evening Peak	Night off-Peak	Day Peak	Evening Peak	Night off-Peak
Region	%	%	%	%	%	%	%	%	%
NR	90%	0%	0%	90%	0%	0%	90%	0%	0%
WR	80%	0%	0%	85%	0%	0%	90%	0%	0%
SR	80%	0%	0%	85%	0%	0%	90%	0%	0%
ER	80%	0%	0%	85%	0%	0%	90%	0%	0%
NER	80%	0%	0%	85%	0%	0%	90%	0%	0%



**Table-II(b)**  
**Capacity Factor for Wind Generation**

Season	Monsoon			Summer			Winter		
Scenarios	Day Peak	Evening Peak	Night off-Peak	Day Peak	Evening Peak	Night off-Peak	Day Peak	Evening Peak	Night off-Peak
Region	%	%	%	%	%	%	%	%	%
NR	50%	70%	60%	50%	70%	60%	10%	35%	10%
WR	55%	75%	65%	55%	75%	65%	10%	20%	20%
SR	55%	75%	65%	55%	75%	65%	0%	20%	0%
ER	0%	0%	0%	0%	0%	0%	0%	0%	0%
NER	0%	0%	0%	0%	0%	0%	0%	0%	0%

Note: The above factors may be revised from time to time.

## References:

1. Manual on Transmission Planning Criteria – 2013, CEA
2. The Electricity Act, 2003
3. Central Electricity Authority (Technical Standards for Connectivity to the Grid) Regulations, 2007 and its amendments.
4. Central Electricity Regulatory Commission (Indian Electricity Grid Code) Regulations, 2010 and its amendments.
5. Central Electricity Regulatory Commission (Grant of Connectivity, Long-term Access and Medium-term Open Access in inter-State Transmission and related matters) Regulations, 2009 and its amendments.
6. Central Electricity Authority (Technical Standards for Construction of Electrical Plants and Electric Lines) Regulations, 2022.
7. Planning Methodology and Criteria report, 1995 of M/s PTI
8. Transmission Reliability Criteria, Alberta Electric System Operator, Canada
9. Reliability Standards for the Bulk Electric Systems of North America, NERC
10. Transmission Planning Criteria - 1998, ESB National Grid
11. National Electricity Transmission System Security and Quality of Supply, National Grid, UK
12. Power System Stability and Control – Book by P. Kundur
13. Definition and Classification of Power System Stability, IEEE/CIGRE Joint Task Force -2004.
14. Report on “Standard Specifications and Technical Parameters for Transformers and Reactors (66 kV & above voltage class)”, CEA
15. Report of Task Force on Cyclone Resilient Robust Electricity Transmission and Distribution Infrastructure in the Coastal Areas, CEA
16. IEEE Technical Report PES-TR65
17. IEEE Technical Report PES-TR83